

CATALOG NO. WH202j  
Dated December 2001  
Supersedes WH202g Dated Dec. 1997

# WEATHERHEAD® TUBE & PIPE FITTINGS

Master Catalog



**BUILT TO A TOUGHER STANDARD™**

**BOSTON WEATHERHEAD™**



# Table of Contents

## APPLICATION DATA

Safety Information	1-2
Visual Quick Reference Index	3-13
Numbering Systems	14
Tube Fitting Selector Chart	15
Thread Specifications/Fitting Identification	16-18
Tubing Section	19-25
Flare Dimensions	26
Tubing Installation	27
Chemical Compatibility Chart	28-32

## PLASTIC TUBING

Nylon 11 (Air Brake)	33
Polyvinyl Chloride	33
Nylon 6/6	33
Polyethylene	34
Polyamide - Nylon 11	34
Polyamide - Nylon 11 Metric Tubing	34

## BRASS FITTINGS

Introduction	35
Inverted Flare	36-40
SAE 45° Flare	41-46
Compression	47-52
SELFALIGN®	53-59
POLYLINE® FLARELESS	60-65
PUSH>CONNECT®	66-71
PUSH>CONNECT® METRIC	72-75
PUSH>CONNECT® FLOW CONTROLS	76-77
PLUS, PUSH>CONNECT® PLUS	78-79
MINI-BARB®	80-83
QUICK>CONNECT® Airbrake	84-92
Air Brake (Nylon Tubing)	93-98
Air Brake (Copper Tubing)	99-103
THREADED SLEEVE®	104-105
Pipe	106-111
Needle Valves	112-115
Drain Cocks	116-118
Truck Valves & Plastic Drain-Cocks	119
Ground Plug & Multiple Shut-Off Valves	120-122
Special Adapters	123-127
Hydraulic Brake Fittings	128-130
Steel Brake Lines	130

## PLASTIC FITTINGS

Molded Compression Tube Fittings	131-137
Plastic Connection Fittings	138

## STEEL FITTINGS

Introduction	139
Pipe	140-148
FOR-SEAL®	149-158
SAE 37° (JIC) FLARE-TWIN®	159-178
Split Flange Adapters and Kits	179-180
Din	181-183
Metric	184-185
BSP	186-189
Flareless - 7000 Series ERMETO®	190-202
Straight Thread O-Ring Adapters	203-213
NPSM Female Swivel Adapters	214-219

## FITTING RELATED PRODUCTS

Coiled Air Brake & Gladhand Couplings	220
Cable Controls	221-222
Presetting Tools	223
Counterbore Tools & O-Ring Kit	224
Measuring Tool Kits	225
Assembly & Tube Cutting Equipment	226
Tube Cutting Equipment	227
Tube Bending Tools	228
Tube Flaring Tools	229-230
Brazing Tools	230-231
Label Sets	231
Cabinets	232
Assortments	233-250

## MISCELLANEOUS

BWD Locations and Certifications	251
Conversion Chart	252
Technical Torque Specifications	253
Technical Support Information	254
Glossary	255-259
Index	260-266
Weatherhead Reply Cards	Insert
Weatherhead Warranty	Back Inside Cover

**BUILT TO A TOUGHER STANDARD™**

**WEATHERHEAD®**



### **WARNING**

#### **Selection of Tubing**

Selecting the proper Weatherhead tubing for a given application is essential to the proper operation and safe use of the tubing and related equipment. Inadequate attention to the selection of the tubing for your application can result in leakage, bursting, or other failure which can cause serious bodily injury or property damage from spraying fluids or flying projectiles. In order to avoid serious bodily injury or property damage resulting from selection of the wrong tubing, you should carefully review the information in this catalog. Some of the factors that are involved in the selection of the proper tubing are:

- material of tubing
- tubing size
- tubing length
- tubing end connections
- fluid conveyed (compatibility)
- bends
- temperature
- tubing pressure rating
- installation design

These factors and the other information in this catalog should be considered by you in selecting the proper tubing for your application. If you have any questions regarding the proper tubing for your application, please contact the Boston Weatherhead Division of Dana Corporation, Technical Support 1-800-PRO-DANA.

#### **Proper Selection of Tube Fittings**

Selecting the proper Weatherhead tube fittings for the application is essential to the proper operation and safe use of tubing and related equipment. Inadequate attention to the selection of the end fittings for your application can result in tube leakage, bursting, or other failure which can cause serious injury or property damage from spraying fluids or flying projectiles. In order to avoid serious bodily injury or property damage resulting from selection of the wrong tube end fitting, you should carefully review the information in this catalog. Some of the factors which are involved in the selection of the proper tube end fittings are:

- tube fitting
- compatibility with tubing
- temperature
- installation design
- tubing size
- corrosion requirements

These factors and the other information in this catalog should be considered by you in selecting the proper tube end fitting for your application.

If you have any questions regarding the proper tube end fittings for your application, please contact the Boston Weatherhead Division of Dana Corporation, Technical Support at 1-800-PRO-DANA.

 **WARNING****Tubing Installation**

Proper installation of the tubing is essential to the proper operation and safe use of the tubing and related equipment. Improper installation of the tubing can result in serious injury or property damage. In order to avoid serious bodily injury or property damage resulting from improper installation of the tubing, you should carefully review the information in this catalog regarding tubing installation. Some of the factors you must consider in installing the tubing properly are:

- proper installation procedures
- protection from high temperature sources
- stress
- changes in length
- twisting
- rubbing and abrasion

These factors and other information in this catalog regarding tubing installation should be considered by you before installing the tubing.

If you have any questions regarding proper installation of the tubing, please contact the Boston Weatherhead Division of Dana Corporation, Technical Support 1-800-PRO-DANA.

**Tubing Assembly**

Changes in materials, finishes, and assembly techniques may affect the sealing or holding capability of the joint. Due to the great variety of possible assembly scenarios, assembly procedures should be tested to determine if the joint is adequate for its intended use. We stress the importance of referring to assembly instructions on page 9 for determining the appropriate tightening procedure. Improper assembly or overtightening could result in fitting leakage, tubing separation or other failures which could cause serious bodily injury or property damage from spraying fluids or flying projectiles.

These factors and other information in this catalog regarding tubing assembly should be considered by you before installing the tubing.

If you have any questions regarding proper assembly and installation of the tubing, please contact the Boston Weatherhead Division of Dana Corporation, Technical Support 1-800-PRO-DANA.

**Fitting Dimensions**

Boston Weatherhead molded compression fittings as described in this catalog may not reflect running changes made to improve part performance. Check with Boston Weatherhead Division of Dana Corporation, Technical Support 1-800-PRO-DANA in critical applications.

**Operating Pressures**

Operating pressures of Boston Weatherhead molded compression fittings are regulated by ambient and fluid temperatures, type of fluid being carried, tubing type and conditions of mechanical abuse. Pressures in excess of above specifications in all fitting sizes should be tested by the customer for their particular application.

### INVERTED FLARE

<b>Tube Nut (Steel)</b> <p>105x pg. 37</p>	<b>Tube Nut (Brass)</b> <p>100x pg. 37</p>	<b>Plug (Steel)</b> <p>131x pg. 37</p>	<b>Tube Nut Long (Steel)</b> <p>7896x pg. 37</p>	<b>Union</b> <p>252x pg. 37</p>	<b>Adapter SAE 45° Flare to Inv. Flare</b> <p>pg. 38</p>	<b>Male Connector</b> <p>202x pg. 38</p>
<b>Female Connector</b> <p>252x pg. 38</p>	<b>45° Male Elbow</b> <p>352x pg. 38</p>	<b>Union Elbow</b> <p>502x pg. 39</p>	<b>Male Elbow</b> <p>402x pg. 39</p>	<b>Female Elbow</b> <p>452x pg. 39</p>	<b>Union Tee</b> <p>702x pg. 39</p>	<b>Male Run Tee</b> <p>752x pg. 40</p>
<b>Male Branch Tee</b> <p>602x pg. 40</p>	<b>Female Branch Tee</b> <p>652x pg. 40</p>	<b>Adapter Tee</b> <p>552x pg. 40</p>				





### POLYLINE® FLARELESS

<b>Cap</b> <p>1229x pg. 61</p>	<b>Plastic Sleeve</b> <p>1260x pg. 61</p>	<b>Brass Sleeve</b> <p>1260x-B pg. 61</p>	<b>Brass Nut</b> <p>1261x pg. 61</p>	<b>Brass Nut Assy (w/Plastic Sleeve)</b> <p>1261x-A pg. 62</p>	<b>Brass Nut Assy (w/Brass Sleeve)</b> <p>1261x-B pg. 62</p>	<b>Brass Bulkhead Nut</b> <p>1202x pg. 62</p>
<b>Union</b> <p>1262x pg. 62</p>	<b>Selfalign to Polyline Union</b> <p>1262x-S pg. 63</p>	<b>Male Connector</b> <p>1268x pg. 63</p>	<b>Female Connector</b> <p>1266x pg. 63</p>	<b>Bulkhead Union</b> <p>1274x pg. 63</p>	<b>Selfalign to Polyline Bulkhead Union</b> <p>1274x-S pg. 64</p>	<b>Union Elbow</b> <p>1265x pg. 64</p>
<b>Male Elbow</b> <p>1269x pg. 64</p>	<b>Female Elbow</b> <p>1270x pg. 64</p>	<b>Union Tee</b> <p>1264x pg. 65</p>	<b>Male Run Tee</b> <p>1271x pg. 65</p>	<b>Male Branch Tee</b> <p>1272x pg. 65</p>	<b>Female Branch Tee</b> <p>1277x pg. 65</p>	

### GROUND PLUG & MULTIPLE SHUT-OFFS

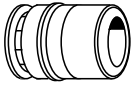
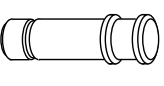
<b>Draincock</b> <p>pg. 120</p>	<b>Ground Plug Drain</b> <p>pg. 120</p>	<b>Compression Flareless 3-Way Shut-Off</b> <p>pg. 120</p>	<b>SAE 45° Flare Double</b> <p>pg. 120</p>	<b>SAE 45° Flare Straight-Away</b> <p>pg. 121</p>	<b>Compression Double</b> <p>pg. 121</p>	<b>Compression Straight-Away</b> <p>pg. 121</p>
<b>Male to Female Pipe</b> <p>pg. 121</p>	<b>Truck Shut-Off to Female Pipe</b> <p>pg. 121</p>	<b>Marine Shut-Off Male to Female Pipe</b> <p>pg. 122</p>	<b>Female Pipe</b> <p>pg. 122</p>	<b>3-Way Shut-Off</b> <p>pg. 122</p>	<b>3-Way Multiple Shut-Off</b> <p>pg. 122</p>	<b>4-Way Multiple Shut-Off</b> <p>pg. 122</p>

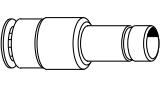
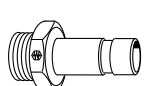
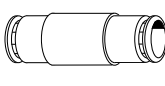
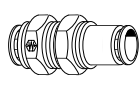
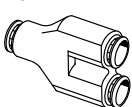
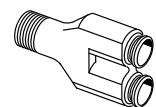
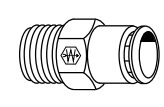
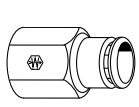

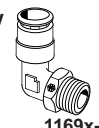
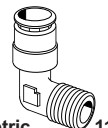
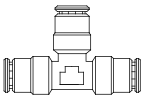
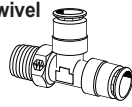
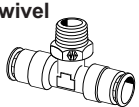
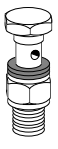
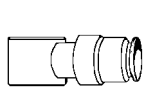
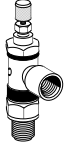

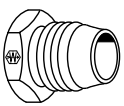
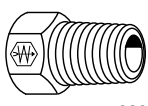
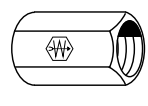
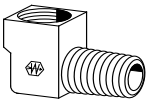
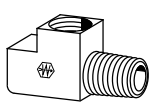

## PUSH > CONNECT



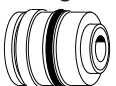
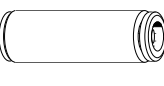
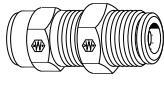

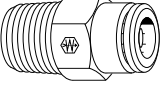
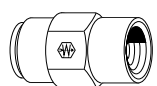

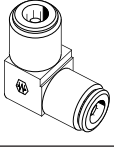
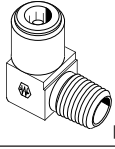
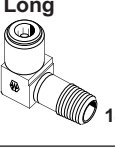
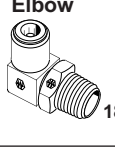
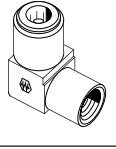
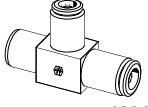
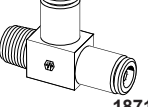

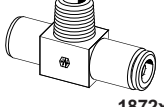
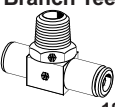
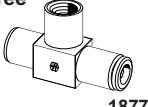
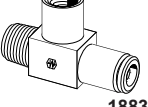
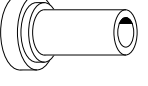

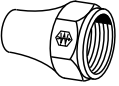
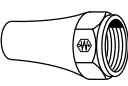
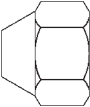
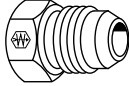
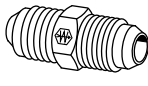





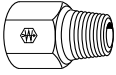
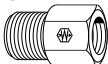
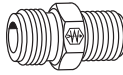
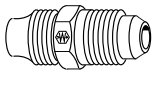
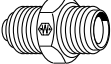
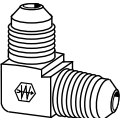
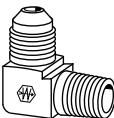
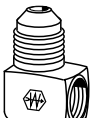

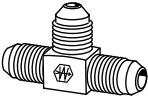
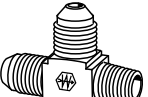
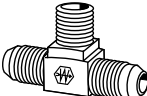
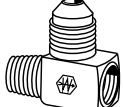



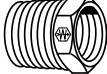

<b>Cartridge</b>  Metric 1611x pg. 72 pg. 67	<b>Plug (Plastic)</b>  Metric 1129x pg. 72 pg. 67	<b>Double Union</b>  Metric 1105x pg. 72 pg. 67	<b>Reducer</b>  Metric 1109x pg. 72 pg. 67	<b>Stem Adapter</b>  Metric 1180x pg. 72 pg. 68	<b>Union</b>  Metric 1162x pg. 72 pg. 68	<b>Bulkhead Union</b>  Metric 1174x pg. 72 pg. 68
<b>Union "Y"</b>  Metric 1107x pg. 73 pg. 68	<b>Male "Y"</b>  Metric 1108x pg. 73 pg. 69	<b>Male Connector</b>  Metric 1168x pg. 73 pg. 69	<b>Female Connector</b>  Metric 1166x pg. 73 pg. 69	<b>Union Elbow</b>  Metric 1165x pg. 74 pg. 69	<b>Swivel Male Elbow</b>  Metric 1169x-S pg. 74 pg. 70	<b>Male Elbow</b>  Metric 1169x pg. 74 pg. 70
<b>Union Tee</b>  Metric 1164x pg. 74 pg. 70	<b>Male Run Tee Swivel</b>  Metric 1171x-S pg. 75 pg. 70	<b>Male Branch Tee Swivel</b>  Metric 1172x-S pg. 75 pg. 71	<b>Stud Manifolds</b>  pg. 71	<b>Banjos</b>  pg. 71	<b>Flow Controls</b>  pg. 77	PUSH > CONNECT PLUS see pages 78 & 79.

## THREADED SLEEVE







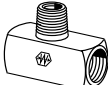
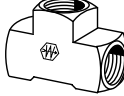
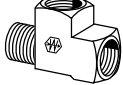
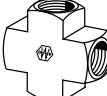



<b>Nut</b>  6100x pg. 105	<b>Male Connector</b>  6200x pg. 105	<b>Union</b>  6300x pg. 105	<b>Male Elbow</b>  6400x pg. 105	<b>Adapter Tee</b>  6550x pg. 105		
--	---	--	---	--	--	--

## QUICK > CONNECT AIR BRAKE

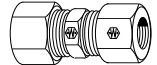

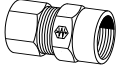
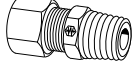
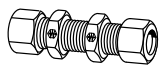



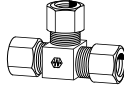
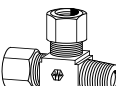
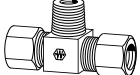
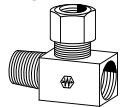

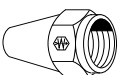
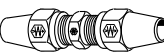

<b>Encapsulated Cartridge</b>  1861x pg. 86	<b>Union</b>  1862x pg. 86	<b>Bulkhead Union</b>  1874x pg. 86	<b>Female Bulkhead Union</b>  1873x pg. 86	<b>Male Connector</b>  1868x pg. 87	<b>Female Connector</b>  1866x pg. 87	<b>Male Elbow 45°</b>  1880x pg. 88
<b>Swivel Male 45° Elbow</b>  1880x-S pg. 88	<b>Union Elbow</b>  1865x pg. 88	<b>Male Elbow 90°</b>  1869x pg. 89	<b>Male Elbow 90° Long</b>  1869x-L pg. 89	<b>Swivel Male 90° Elbow</b>  1869x-S pg. 90	<b>Female Elbow</b>  1870x pg. 90	<b>Union Tee</b>  1864x pg. 90
<b>Male Run Tee</b>  1871x pg. 91	<b>Swivel Male Run Tee</b>  1871x-S pg. 91	<b>Male Branch Tee</b>  1872x pg. 91	<b>Swivel Male Branch Tee</b>  1872x-S pg. 92	<b>Female Branch Tee</b>  1877x pg. 92	<b>Adapter Tee</b>  1883x pg. 92	<b>Pressure Plug</b>  1829x pg. 92

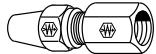
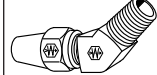
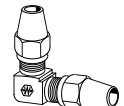
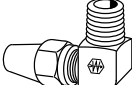
SAE 45° FLARE						
<b>Nut</b>  1110x pg. 42	<b>Long Nut</b>  41x pg. 42	<b>Cap</b>  40x pg. 42	<b>Plug</b>  39x pg. 42	<b>Union</b>  42x pg. 42	<b>Male Connector</b>  48x pg. 42	<b>Female Connector</b>  46x pg. 43
<b>Male Ball Check Connector</b>  43x pg. 43	<b>45° Male Elbow</b>  54x pg. 43	<b>Fem 45° Flare Swivel to Male SAE 45° Elbow (Steel)</b>  9154x pg. 43	<b>Restriction Pipe Adapter</b>  pg. 44	<b>Carburetor to Fuel Line Adapter</b>  pg. 44	<b>Fuel Line Adapter</b>  pg. 44	<b>AC Type Adapter</b>  pg. 44
<b>Adapter SAE 45° Flare to Inv. Flare</b>  pg. 44	<b>Union Elbow</b>  55x pg. 45	<b>Male Elbow</b>  49x pg. 45	<b>Female Elbow</b>  50x pg. 45	<b>90° Elbow 45° Female Swivel to SAE 45° (Steel)</b>  9151x pg. 45	<b>Union Tee</b>  44x pg. 46	<b>Male Run Tee</b>  51x pg. 46
<b>Male Branch Tee</b>  45x pg. 46	<b>Adapter Tee</b>  56x pg. 46					
PIPE						
<b>Cap</b>  3129x pg. 107	<b>Slotted Plug</b>  3150x pg. 107	<b>Square Head Plug</b>  3151x pg. 107	<b>Hex Head Plug</b>  3152x pg. 107	<b>Hex Socket Plug</b>  3153x pg. 107	<b>Adapter</b>  3200x pg. 107	<b>Bushing</b>  3220x pg. 108
<b>Union</b>  3250x pg. 108	<b>Coupling</b>  3300x pg. 108	<b>Reducer Coupling</b>  3300x pg. 108	<b>Hex Nipple</b>  3325x pg. 108	<b>Close Nipple</b>  3326x pg. 109	<b>Long Nipple</b>  3331x pg. 109	<b>Bulkhead Coupling (brass)</b>  pg. 109 & 110
<b>45° Street Elbow</b>  3350x pg. 110	<b>Street Elbow</b>  3400x pg. 110	<b>Elbow</b>  3500x pg. 111	<b>Male Branch Tee</b>  3600x pg. 111	<b>Tee</b>  3700x pg. 111	<b>Street Tee</b>  3750x pg. 111	<b>Cross</b>  3950x pg. 111



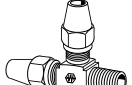
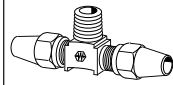
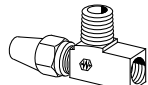
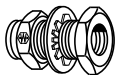
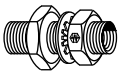







## COMPRESSION & SELFALIGN FITTINGS

<b>Tube Support For Plastic Tubing</b>  2030x pg. 48 & 55	<b>Sleeve</b>  60x pg. 48      601x pg. 55	<b>Nut</b>  61x pg. 48      611x pg. 55	<b>Long Nut</b>  1611x pg. 49 & 55	<b>Bulkhead Nut</b>  0102x pg. 49 & 56	<b>Union</b>  62x pg. 49      621x pg. 56	<b>Male Connector</b>  68x pg. 49      681x pg. 56
<b>Female Connector</b>  66x pg. 50      661x pg. 57	<b>Male Ball Check Connector</b>  63x pg. 50      631x pg. 57	<b>Bulkhead Union</b>  74x pg. 50      741x pg. 57	<b>Male Elbow</b>  69x pg. 51      691x pg. 58	<b>Union Elbow</b>  65x pg. 51      651x pg. 57	<b>Female Elbow</b>  70x pg. 51      701x pg. 58	<b>Union Tee</b>  64x pg. 52      641x pg. 58
<b>Male Run Tee</b>  71x pg. 52      711x pg. 59	<b>Male Branch Tee</b>  72x pg. 52      721x pg. 59	<b>Adapter Tee</b>  76x pg. 52      761x pg. 59				

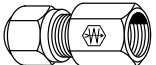
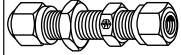
## AIR BRAKE FITTINGS FOR COPPER TUBING

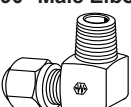
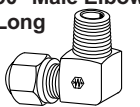

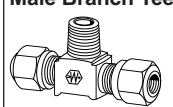
<b>Sleeve</b>  1360x pg. 100	<b>Nut</b>  1361x pg. 100	<b>Union</b>  1362x pg. 100	<b>Male Connector</b>  1368x pg. 100	<b>Female Connector</b>  1366x pg. 101	<b>45° Male Elbow</b>  1380x pg. 101	<b>Union Elbow</b>  1365x pg. 101
<b>90° Male Elbow</b>  1369x pg. 101	<b>90° Male Elbow Long</b>  1369x-L pg. 101	<b>90° Female Elbow</b>  1370x pg. 102	<b>Union Tee</b>  1364x pg. 102	<b>Male Run Tee</b>  1371x pg. 102	<b>Male Branch Tee</b>  1372x pg. 102	<b>Adapter Tee</b>  1382x pg. 102
<b>Bulkhead Coupling (Brass)</b>  pg. 103	<b>Bulkhead Coupling (Brass)</b>  pg. 103	<b>Bulkhead Coupling (Brass)</b>  pg. 103	<b>Drain Cock</b>  W15310 pg. 103	<b>Shut-Off Valve</b>  W2033L pg. 103	<b>External Seat Draincock</b>  145 pg. 103	

## AIR BRAKE FITTINGS FOR NYLON TUBING





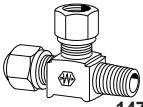
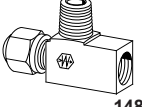
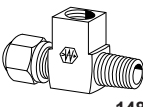
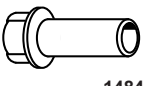

<b>Sleeve</b>  1460x pg. 94	<b>Nut</b>  1461x pg. 94	<b>Union</b>  1462x pg. 94	<b>Male Connector</b>  1468x pg. 95	<b>Female Connector</b>  1466x pg. 95	<b>Bulkhead Union</b>  1474x pg. 95	<b>45° Male Elbow</b>  1480x pg. 95
<b>Union Elbow</b>  1465x pg. 96	<b>90° Male Elbow</b>  1469x pg. 96	<b>90° Male Elbow Long</b>  1469x-L pg. 96	<b>90° Female Elbow</b>  1470x pg. 96	<b>Union Tee</b>  1464x pg. 97	<b>Male Branch Tee</b>  1472x pg. 97	<b>Female Branch Tee</b>  1477x pg. 97



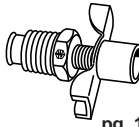

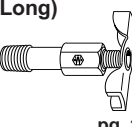
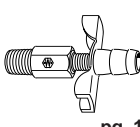

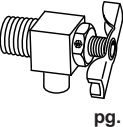
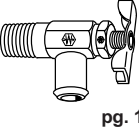
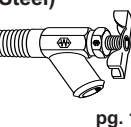
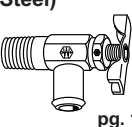
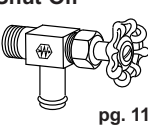
## AIR BRAKE FITTINGS FOR NYLON TUBING CONTINUED

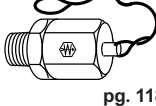
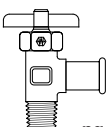
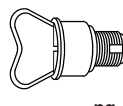
<b>Male Run Tee</b>  1471x pg. 97	<b>Adapter Tee</b>  1482x pg. 98	<b>Adapter Tee</b>  1483x pg. 98	<b>Insert</b>  1484x pg. 98	<b>Gauge Ring</b>  1485x pg. 98		
---	--	--	---	---	--	--



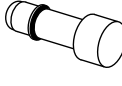
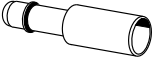
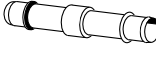
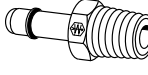
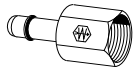
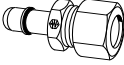

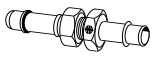
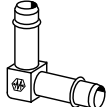
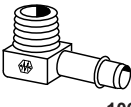

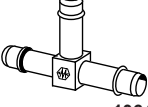
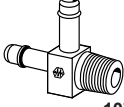
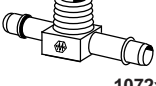
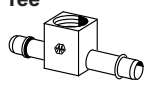
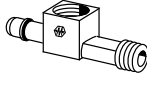

## DRAINCOCKS

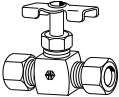
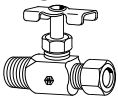
<b>External Seat</b>  pg. 116	<b>External Seat</b>  pg. 116	<b>Internal Seat</b>  pg. 116	<b>Internal Seat (Long)</b>  pg. 116	<b>Internal Seat</b>  pg. 117	<b>Internal Seat Drain Valve</b>  pg. 117	<b>Air Vent</b>  pg. 117
<b>Angle Bib Drain</b>  pg. 117	<b>Angle Bib Drain</b>  pg. 117	<b>Hose to Pipe (Steel)</b>  pg. 118	<b>Hose to Pipe (Steel)</b>  pg. 118	<b>Pipe to Hose Shut-Off</b>  pg. 118	<b>Gasoline Shut-Off</b>  pg. 118	<b>Air Tank Drain Valve</b>  pg. 118
<b>Truck Valves</b>  pg. 119	<b>Plastic Drain Cocks</b>  pg. 119					

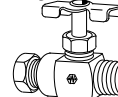

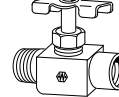
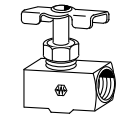



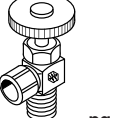































## MINI-BARB®

<b>Plug</b>  1073x pg. 81	<b>Solder Connector</b>  1079x pg. 81	<b>Union</b>  1062x pg. 81	<b>Male Connector</b>  1068x pg. 81	<b>Female Connector</b>  1066x pg. 81	<b>Compression Connector</b>  1078x pg. 81	<b>Bulkhead Compression Connector</b>  1067x pg. 82
<b>Bulkhead Union</b>  1074x pg. 82	<b>Union Elbow</b>  1065x pg. 82	<b>90° Male Elbow</b>  1069x pg. 82	<b>90° Female Elbow</b>  1070x pg. 82	<b>Union Tee</b>  1064x pg. 83	<b>Male Run Tee</b>  1071x pg. 83	<b>Male Branch Tee</b>  1072x pg. 83
<b>Female Branch Tee</b>  1077x pg. 83	<b>Adapter Tee</b>  1075x pg. 83					

## NEEDLE VALVES

<b>Compression Double</b>  pg. 113	<b>Compression Straight-Away</b>  pg. 113	<b>Compression Angle</b>  pg. 113	<b>Inverted Straight-Away</b>  pg. 113	<b>Male Pipe</b>  pg. 114	<b>Female to Male Pipe</b>  pg. 114	<b>Female Pipe</b>  pg. 114
<b>SAE 45° Flare Double</b>  pg. 114	<b>SAE 45° Flare Straight-Away</b>  pg. 115	<b>SAE 45° Flare Angle</b>  pg. 115	<b>Polyline Straight-Away</b>  pg. 115	<b>Polyline Angle</b>  pg. 115		

















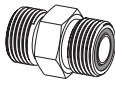
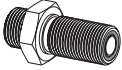

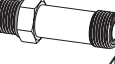

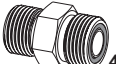







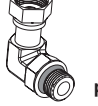
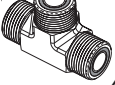















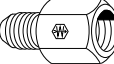
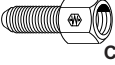

## PIPE FITTINGS

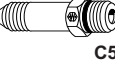
<b>Seal-Nut for Male Pipe Threads</b>  C3059x pg. 141	<b>Hex Socket Plug</b>  C3169x pg. 141	<b>Square Head Plug</b>  C3179x pg. 141	<b>Hex Head Plug</b>  Stainless Steel No. 3171x C3159x pg. 141	<b>Bushing</b>  Stainless Steel No. 3121x C3109x pg. 142	<b>Straight Thread O-Ring to Female Pipe Adapter</b>  C3269x pg. 142	<b>Adapter</b>  Stainless Steel No. 3221x C3209x pg. 142
<b>Female Straight Thread O-Ring to Male Pipe Adapter</b>  C3239x pg. 143	<b>Coupling</b>  Stainless Steel No. 3321x C3309x pg. 143	<b>Hex Nipple</b>  Stainless Steel No. 3081x C3069x pg. 143	<b>Male Connector</b>  4205x pg. 143	<b>Male Straight Thread O-Ring to Male Pipe Adapter</b>  C3249x pg. 143	<b>Bulkhead Coupling</b>  W05465 pg. 144	<b>Bulkhead Coupling</b>  W05498 pg. 144
<b>Bulkhead Coupling</b>  W05730 pg. 144	<b>45° Elbow</b>  C3559x pg. 144	<b>45° Elbow</b>  TF3559x pg. 144	<b>45° Street Elbow</b>  Stainless Steel No. 3371x C3359x pg. 144	<b>45° Street Elbow</b>  TF3359x pg. 144	<b>90° Elbow</b>  Stainless Steel No. 3521x C3509x pg. 145	<b>90° Elbow</b>  TF3509x pg. 145
<b>90° Street Elbow</b>  Stainless Steel No. 3421x C3409x pg. 145	<b>90° Street Elbow</b>  TF3409x pg. 145	<b>90° Straight Thread O-Ring Male Elbow</b>  C3459x pg. 146	<b>90° Straight Thread O-Ring Male Elbow</b>  TF3459x pg. 146	<b>90° Straight Thread O-Ring Male Elbow Long</b>  C3469x pg. 146	<b>90° Straight Thread O-Ring Male Elbow to Male Pipe</b>  TF3569x pg. 146	<b>90° Male Elbow</b>  Stainless Steel No. 3541x C3529x pg. 147
<b>90° Male Elbow</b>  TF3529x pg. 147	<b>Tee</b>  Stainless Steel No. 3721x C3709x pg. 147	<b>Tee</b>  TF3709x pg. 147	<b>Male Branch Tee</b>  Stainless Steel No. 3621x C3609x pg. 147	<b>Male Branch Tee</b>  TF3609x pg. 147	<b>Male Run Tee</b>  Stainless Steel No. 3771x C3759x pg. 148	<b>Male Run Tee</b>  TF3759x pg. 148
<b>Female Run Tee</b>  TF3805x pg. 148	<b>Cross</b>  C3959x pg. 148	<b>Cross</b>  TF3959x pg. 148	<b>Straight Thread O-Ring</b>  7629x pg. 148			

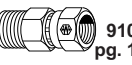

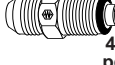
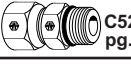

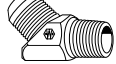





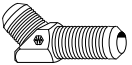











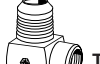





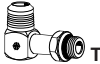



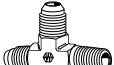
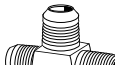



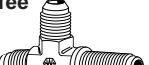

# Steel Fittings

## Visual Index





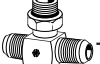



















APPLICATION

FOR-SEAL®						
<b>Tailpiece Silver Braze</b>  4165x pg. 152	<b>For-Seal® Cadmium Free Braze Ring</b>  4640x pg. 152	<b>Bulkhead Nut</b>  4929x pg. 152	<b>Nut</b>  4105x pg. 152	<b>Cap</b>  4129x pg. 152	<b>Plug</b>  4229x pg. 153	<b>Union</b>  4305x pg. 153
<b>Bulkhead Union</b>  4325x pg. 153	<b>Straight Thread O-Ring Connector</b>  4315x pg. 153	<b>Straight Thread O-Ring Extended Connector</b>  4316x pg. 154	<b>Male 37° Flare to Female For-Seal</b>  4213x pg. 154	<b>For-Seal Male to Ermeto Connector</b>  4307x pg. 154	<b>45° Male Elbow</b>  4325x pg. 155	<b>Straight Thread O-Ring Connector 45° Elbow</b>  4365x pg. 155
<b>45° Bulkhead Elbow</b>  4375x pg. 155	<b>Union 90° Elbow</b>  4505x pg. 155	<b>Bulkhead Union 90° Elbow</b>  4525x pg. 156	<b>90° Male Elbow</b>  4405x pg. 156	<b>Straight Thread O-Ring 90° Elbow</b>  4515x pg. 156	<b>90° Elbow Straight Thread Swivel - Long</b>  4405x pg. 157	<b>90° Straight Thread Swivel</b>  4535x pg. 157
<b>Union Tee</b>  4705x pg. 157	<b>Straight Thread Branch Tee</b>  4715x pg. 157	<b>Straight Thread Run Tee</b>  4716x pg. 158	<b>Bulkhead Run Tee</b>  4726x pg. 158	<b>Male For-Seal Cross</b>  4929x pg. 158	<b>O-Ring For-Seal</b>  4629x pg. 158	
SAE 37° (JIC) FLARE-TWIN						
<b>Sleeve 3 Piece</b>  Stainless Steel No. C5165x 5177x pg. 161	<b>Sleeve 3 Piece Metric</b>  C5165x pg. 161	<b>Nut 3 Piece</b>  Stainless Steel No. C5105x 5117x pg. 161	<b>Nut 2 Piece (Short)</b>  C5125x pg. 161	<b>Nut 2 Piece</b>  C5115x pg. 161	<b>Bulkhead Nut</b>  Stainless Steel No. C5924x 7936x pg. 162	<b>Cap</b>  Stainless Steel No. C5129x 5141x pg. 162
<b>Plug</b>  Stainless Steel No. C5229x 5241x pg. 162	<b>Reducer</b>  Stainless Steel No. C5015x 5027x pg. 162	<b>Small Hex Union</b>  Stainless Steel No. C5305x 5317x pg. 163	<b>Large Hex Union</b>  Stainless Steel No. C5306x 5318x pg. 163	<b>Bulkhead Union</b>  Stainless Steel No. C5325x 5337x pg. 163	<b>Male Connector</b>  Stainless Steel No. C5205X 5217x pg. 164	<b>Female Connector</b>  C5255x pg. 164
<b>Female Bulkhead Connector</b>  C5275x pg. 164	<b>Male SAE (JIC) 37° Female For-Seal</b>  4213x pg. 165	<b>Straight Thread O-Ring Connector</b>  Stainless Steel No. C5315x 5327x pg. 165	<b>Straight Thread O-Ring Extended Connector</b>  C5316x pg. 165	<b>Adapter</b>  C5880x pg. 166	<b>Female SAE (JIC) 37° Swivel to Male Pipe Adapter</b>  9100x pg. 166	<b>Male SAE (JIC) 37° to Male Metric Stand Pipe</b>  MC5019x pg. 166
<b>Male SAE (JIC) 37° to O-Ring Port Adapter</b>  41157x pg. 166	<b>Female SAE (JIC) 37° Swivel to Male Straight Thread O-Ring</b>  C5216x pg. 167	<b>Female SAE (JIC) 37° Swivel to Female Pipe</b>  C5256x pg. 152	<b>45° Male Elbow</b>  Stainless Steel No. C5355x 5367x pg. 167	<b>45° Male Elbow</b>  TF5355x pg. 167	<b>Swivel Nut 45° Elbow</b>  Stainless Steel No. C5356x 5368x pg. 168	<b>Swivel Nut 45° Elbow</b>  TF5356x pg. 168







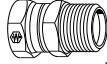
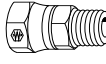
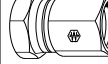
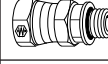

## SAE 37° (JIC) FLARE-TWIN cont.

<b>45° Bulkhead Union Elbow</b>  TF5375x pg. 168	<b>Straight Thread O-Ring 45° Elbow</b>  C5365x pg. 169	<b>Straight Thread O-Ring 45° Elbow</b>  TF5365x pg. 169	<b>90° Union Elbow</b>  Stainless Steel No. 5517x C5505x pg. 169	<b>90° Union Elbow</b>  TF5505x pg. 169	<b>90° Male Elbow</b>  Stainless Steel No. 5417x C5405x pg. 170	<b>90° Male Elbow</b>  TF5405x pg. 170
<b>90° Male Elbow Long</b>  C5425x pg. 171	<b>90° Male Elbow Long</b>  TF5425x pg. 171	<b>90° Male Elbow Extra Long</b>  TF5435x pg. 171	<b>Bulkhead Union 90° Elbow</b>  Stainless Steel No. 5537x C5525x pg. 171	<b>Bulkhead Union 90° Elbow</b>  TF5525x pg. 171	<b>90° Female Elbow</b>  Stainless Steel No. 5467x C5455x pg. 172	<b>90° Female Elbow</b>  TF5455x pg. 172
<b>Swivel Nut 90° Elbow</b>  Stainless Steel No. 5518x C5506x pg. 172	<b>Swivel Nut 90° Elbow</b>  TF5506x pg. 172	<b>90° Male Pipe to SAE (JIC) 37° Swivel</b>  TF5406x pg. 173	<b>Straight Thread O-Ring 90° Elbow</b>  Stainless Steel No. 5527x C5515x pg. 173	<b>Straight Thread O-Ring 90° Elbow</b>  TF5515x pg. 173	<b>Straight Thread O-Ring 90° Elbow Long</b>  TF5515x pg. 174	<b>Straight Thread O-Ring 90° Elbow Extra Long</b>  TF5515x pg. 174
<b>Union Tee</b>  Stainless Steel No. 5717x C5705x pg. 174	<b>Union Tee</b>  TF5705x pg. 174	<b>Male Run Tee</b>  Stainless Steel No. 5767x C5755x pg. 175	<b>Male Run Tee</b>  TF5755x pg. 175	<b>Female Run Tee</b>  TF5805x pg. 175	<b>Swivel Nut Run Tee</b>  Stainless Steel No. 5718x C5706x pg. 175	<b>Swivel Nut Run Tee</b>  TF5706x pg. 175
<b>Bulkhead Run Tee</b>  TF5726x pg. 161 C5726x pg. 176	<b>Straight Thread O-Ring Run Tee</b>  C5716x pg. 176	<b>Straight Thread O-Ring Run Tee</b>  TF5716x pg. 176	<b>Male Branch Tee</b>  Stainless Steel No. 5617x C5605x pg. 176	<b>Male Branch Tee</b>  TF5605x pg. 176	<b>Female Branch Tee</b>  Stainless Steel No. 5667x C5655x pg. 177	<b>Female Branch Tee</b>  TF5655x pg. 177
<b>Swivel Nut Branch Tee</b>  Stainless Steel No. 5719x C5707x pg. 177	<b>Swivel Nut Branch Tee</b>  TF5707xx pg. 177	<b>Bulkhead Union Tee</b>  Stainless Steel No. 5737x TF5725x pg. 177	<b>Straight Thread O-Ring Branch Tee</b>  C5715x pg. 178	<b>Straight Thread O-Ring Branch Tee</b>  TF5715x pg. 178	<b>Cross</b>  Stainless Steel No. 5967x TF5955x pg. 178	<b>Straight Thread O-Ring</b>  7629x pg. 178

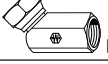
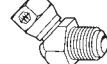
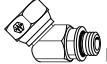
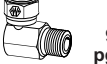
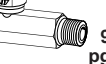
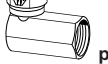
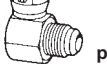















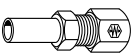
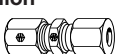

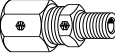



## METRIC/BRITISH PIPE FITTINGS

<b>Metric Flareless Sleeve</b>  7165x pg. 182	<b>Metric Flareless Nut - Light Series</b>  ML7105x pg. 182	<b>Metric Flareless Nut - Heavy Series</b>  MH7105x pg. 182	<b>Male SAE 37° to 24° Metric Tube Seat (Light)</b>  MC5206x pg. 182	<b>Male SAE 37° to 24° Metric Tube Seat (Heavy)</b>  MC5208x pg. 182	<b>Male SAE (JIC) 37° to 60° Metric Tube Seat</b>  MC5207x pg. 182	<b>Male SAE 37° to Male Metric Stand Pipe</b>  MC5019x pg. 182
<b>Sleeve 3 Piece Metric</b>  C5165x pg. 183	<b>Male SAE 37° to Male Metric Straight Thread Connector</b>  MC5315x pg. 183	<b>Female SAE 37° Swivel to Male JIS Tapered Pipe Thread</b>  M9700x pg. 183	<b>Male SAE 37° to Male Metric 90° Straight Thread 90° Elbow</b>  MC5515x pg. 183	<b>Metric Retaining Ring</b>  M7630x pg. 183	<b>Metric O-Ring</b>  M7629x pg. 183	<b>Hex Head Plug</b>  MC3159x pg. 186
<b>Coupling</b>  MC3309x pg. 186	<b>Hex Nipple</b>  MC3069x pg. 187	<b>Male BSPT to Male SAE 37°</b>  MC5205x pg. 187	<b>Male BSPP to Male SAE 37°</b>  MB5315x pg. 188	<b>Female SAE 37° Swivel to Male BSPP</b>  M9800x pg. 188	<b>Female SAE 37° Swivel to Male BSPP</b>  M9600x pg. 188	<b>Male BSPT to Male SAE 37° Elbow</b>  MC5405x pg. 189
<b>Male BSPP to Male SAE 37° Elbow</b>  MB5515x pg. 189	<b>British Retaining Ring</b>  MB7630x pg. 189	<b>British O-Ring</b>  MB7629x pg. 189				

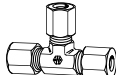
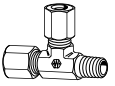
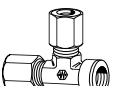

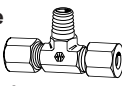
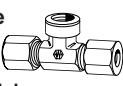











## NPSM FEMALE SWIVEL ADAPTERS

<b>Female Pipe Swivel to Male Pipe</b>  9205x pg. 214	<b>Fem. SAE 37° Swivel to Male Pipe</b>  9100x pg. 214	<b>Fem. Pipe Sw. to Fem. Pipe</b>  9255x pg. 215	<b>Male Straight Thread O-Ring to Fem. Pipe Swivel</b>  9315x pg. 215	<b>Female Pipe Swivel to Male Pipe 45° Elbow</b>  9355x pg. 216	<b>Female Pipe Swivel to Female Pipe 45° Elbow</b>  9385x pg. 216	<b>Female 45° Flare Swivel to Male SAE 45° Elbow</b>  9154x pg. 216
<b>Male Straight Thread O-Ring to Fem. Pipe Sw. 45° Elbow</b>  9365x pg. 217	<b>Female Pipe Swivel to Male Pipe 90° Elbow</b>  9405x pg. 217	<b>Fem. Pipe Sw. to Male Pipe 90° Elbow - Long</b>  9405x pg. 217	<b>Fem. Pipe Sw. to Fem. Pipe 90° Elbow</b>  9455x pg. 218	<b>90° Elbow 45° Female Swivel to SAE 45°</b>  9151x pg. 218	<b>Male Straight Thread O-Ring to Fem. Pipe Sw. 90° Elbow</b>  9515x pg. 218	<b>Male Pipe Swivel to Male Pipe Rigid 90° Elbow</b>  9435x pg. 219
<b>Female Pipe Swivel Tee</b>  9705x pg. 219	<b>Fem. Pipe Sw. to Male Pipe Branch Tee</b>  9406x pg. 219	<b>Fem. Pipe Sw. to Fem. Pipe Branch Tee</b>  9456x pg. 219				

## FLARELESS – 7000 SERIES ERMETO®

<p><b>Sleeve</b></p>  <p>Stainless Steel No. 7165x 7176x pg. 196</p>	<p><b>Sleeve - For Diesel Nut</b></p>  <p>8165x pg. 196</p>	<p><b>Nut</b></p>  <p>Stainless Steel No. 7105x 7117x pg. 196</p>	<p><b>Diesel Nut</b></p>  <p>8112x pg. 196</p>	<p><b>Bulkhead Nut</b></p>  <p>Stainless Steel No. 7924x 7936x pg. 196</p>	<p><b>Cap</b></p>  <p>Stainless Steel No. 7129x 7141x pg. 197</p>	<p><b>Plug</b></p>  <p>Stainless Steel No. 7229x 7241x pg. 197</p>
<p><b>Reducer</b></p>  <p>Stainless Steel No. 7015x 7027x pg. 197</p>	<p><b>Small Hex Union</b></p>  <p>Stainless Steel No. 7305x 7317x pg. 197</p>	<p><b>Large Hex Union</b></p>  <p>Stainless Steel No. 7306x 7318x pg. 197</p>	<p><b>Bulkhead Union</b></p>  <p>Stainless Steel No. 7325x 7337x pg. 198</p>	<p><b>Male Connector</b></p>  <p>Stainless Steel No. 7205x 7217x pg. 198</p>	<p><b>Female Connector</b></p>  <p>Stainless Steel No. 7255x 7267x pg. 198</p>	<p><b>Straight Thread O-Ring Connector</b></p>  <p>Stainless Steel No. 7315x 7327x pg. 198</p>
<p><b>For-Seal® Male to Ermeto® Connector</b></p>  <p>4307x pg. 199</p>	<p><b>45° Male Elbow</b></p>  <p>Stainless Steel No. 7355x 7367x pg. 199</p>	<p><b>90° Union Elbow</b></p>  <p>Stainless Steel No. 7505x 7517x pg. 199</p>	<p><b>90° Male Elbow</b></p>  <p>Stainless Steel No. 7405x 7417x pg. 199</p>	<p><b>90° Female Elbow</b></p>  <p>Stainless Steel No. 7455x 7467x pg. 199</p>	<p><b>Straight Thread O-Ring 90° Elbow</b></p>  <p>Stainless Steel No. 7515x 7527x pg. 200</p>	<p><b>Union Tee</b></p>  <p>Stainless Steel No. 7705x 7717x pg. 200</p>
<p><b>Male Run Tee</b></p>  <p>Stainless Steel No. 7755x 7767x pg. 200</p>	<p><b>Female Run Tee</b></p>  <p>7805x pg. 200</p>	<p><b>Straight Thread O-Ring Run Tee</b></p>  <p>Stainless Steel No. 7716x 7728x pg. 201</p>	<p><b>Male Branch Tee</b></p>  <p>Stainless Steel No. 7605x 7617x pg. 201</p>	<p><b>Female Branch Tee</b></p>  <p>Stainless Steel No. 7655x 7667x pg. 201</p>	<p><b>Straight Thread O-Ring Branch Tee</b></p>  <p>Stainless Steel No. 7715x 7727x pg. 202</p>	<p><b>Cross</b></p>  <p>Stainless Steel No. 7955x 7967x pg. 202</p>
<p><b>Straight Thread O-Ring</b></p>  <p>7629x pg. 1202</p>	<p><b>NOTE: Straight Thread O-Ring Section pages 203-213.</b></p>					

### Molded Compression Tube Fittings

<b>Male Connector</b>  1568x pg. 133	<b>Union Connector</b>  1562x pg. 133	<b>Bulkhead Union</b>  1574x pg. 134	<b>Female Connector</b>  1566x pg. 134	<b>Male Elbow</b>  1569x pg. 134	<b>Female Elbow</b>  1570x pg. 135	<b>Union Elbow</b>  1565x pg. 135
<b>Male Branch Tee</b>  1572x pg. 135	<b>Union Tee</b>  1564x pg. 136	<b>Male Run Tee</b>  1571x pg. 136	<b>Compression Nut</b>  1561x pg. 136	<b>Insert</b>  1584x pg. 137	<b>Cap Nut</b>  1529x pg. 137	<b>Bulkhead Nut</b>  1502x pg. 137
<b>KYNAR Check Valve</b>  1531x pg. 137						

### Additional Plastic Fittings

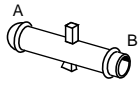
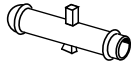
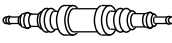
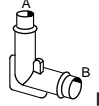
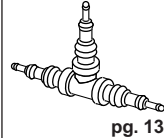
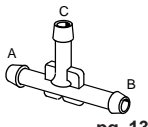
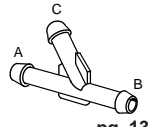
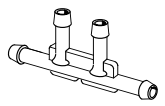
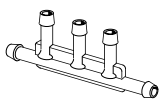
<b>Straight Connector</b>  pg. 138	<b>Restrictor Connector</b>  pg. 138	<b>Universal Connector</b>  pg. 138	<b>Elbow Connector</b>  pg. 138	<b>Universal Tee</b>  pg. 138	<b>3 Way Tee</b>  pg. 138	<b>Y Connector</b>  pg. 138
<b>4 Way Tee</b>  pg. 138	<b>5 Way Tee</b>  pg. 138					

## Numbering Systems

Fittings are identified by a series of numbers separated by the letter "X."

1. The number preceding the "X" is the Catalog "Base Number" and indicates the type of fitting. See Table 1 below for additional base number data.
2. The second number is the tube and/or pipe size in sixteenths of an inch. When a pipe thread for a given tube size follows the SAE standard as shown in Table 2, no other number is required. Example: 48X6 = SAE 45° Flare Male Connector-3/8" tube, 1/4" Male Pipe.
3. If the pipe size is not to the SAE standard, another "X" is added followed by the pipe size indicated in sixteenths of an inch. Example: 1/8" is equal to 2/16" or X2 suffix.

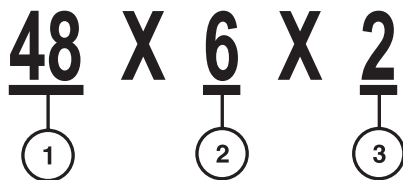
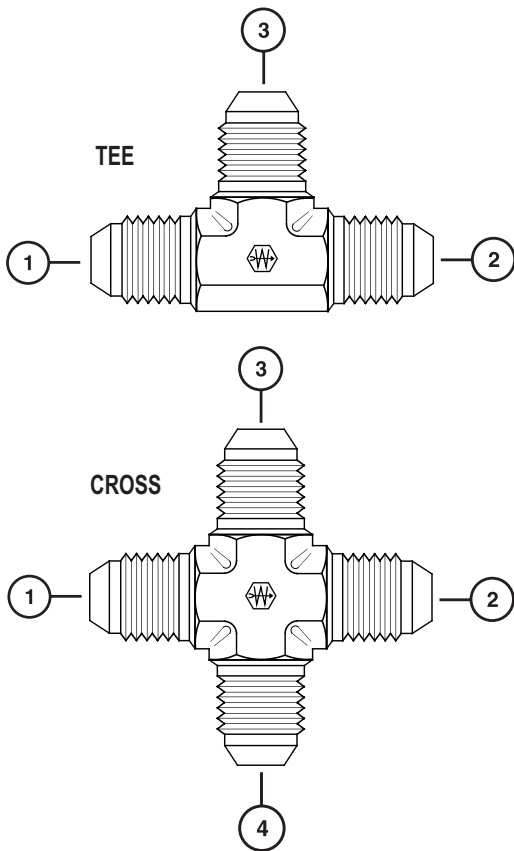

TABLE 1

Type	Example Male Connector	Example Female Connector
45° Flare	48	46
Compression	68	66
Polyline®	1268	1266
Selfalign®	681	661
Air Brake (Nylon)	1468	1466
Air Brake (Copper)	1368	1366
(JIC) Flare-Twin®	C5205	C5255
7000 Series Ermeto®	7205	7255



In designating tube and pipe sizes for tees and crosses that are not SAE standard, indicate the sizes in the sequence shown.

TABLE 2

	Tube Size	Pipe Threads	
		Brass Fitting	Steel Fitting
X2	1/8"	1/8"	1/8"
X3	3/16"	1/8"	1/8"
X4	1/4"	1/8"	1/8"
X5	5/16"	1/8"	1/8"
<b>X6</b>	<b>3/8"</b>	<b>1/4"</b>	<b>1/4"</b>
X7	7/16"	1/4"	1/4"
X8	1/2"	3/8"	3/8"
X10	5/8"	1/2"	1/2"
X12	3/4"	1/2"	3/4"
X14	7/8"	3/4"	3/4"
X16	1"	1"	1"
X20	1-1/4"	No Standard	1-1/4"
X24	1-1/2"	No Standard	1-1/2"
X32	2"	No Standard	2"

## Plating

Standard Weatherhead Steel Pipe and Flare fittings are supplied with Zinc plate and a yellow Dichromate finish (designated with a prefix "C"). Steel Flareless fittings are supplied standard with the exclusive Weathercote®.

To special order alternative plating, add a letter to prefix to the catalog base number. For example, a "C" prefix indicates Zinc plate (C7205X4), and a "W" prefix indicates Weathercote® (W5205X4).



# Tube Fitting Selector Chart

Application

 Refer to safety information regarding tube fitting selection on page 1.

APPLICATION

Weatherhead Fitting Types	Mini-Barb®	Polyline®	Threaded Sleeve	Pipe	Inverted Flare	SAE 45° Flare	Compression	Selfalign®	1400 Series Air Brake	1300 Series Air Brake	Push® Connect	Pipe	SAE 37° Flare-Twin®	7000 Series Ermeto®	For-Seal®	Q-CAB®	Molded Compression		
Fitting Material	Brass	Brass	Brass	Brass	Brass	Brass	Brass	Brass	Brass	Brass	Brass	Steel S.S.	Steel S.S.	Steel S.S.	Steel	Brass	Nylon Poly		
Tube Size (O.D. range in inches)	1/8 1/2	1/8 1/2	1/8 3/8	1/8 3/4	1/8 1	1/8 3/4	1/8 1	1/8 1	1/4 3/4	1/4 3/4	1/8 1/2	1/8 1-1/4	1/8 2	1/8 2	1/4 1-1/2	5/32 3/4			
Maximum Working Pressure (psi) Depends on tubing material, O.D., wall thickness and fitting size.	135	500	500	1200	2000	2000	2000	2000	150	150	250	6000	6,000	5,000	6,000	150			
<b>Vibration (Comparative)</b>																			
Fair																			
Good																			
Excellent																			
<b>Tubing Types</b>																			
Copper		E												A					
Steel																			
Aluminum		E																	
Stainless Steel-Annealed															G				
Stainless Steel - 1/8-Hard															G				
Polyethylene							w/insert	w/insert											
Nylon									w/insert							E			
Polyvinyl Chloride (PVC)							w/insert	w/insert											
Monel																			
Bundy							B	B											
<b>Conforms</b>																			
SAE																			
JIC																			
UL				F	F	F	F												
ASA																			
ASME																			
Military									H										
DOT																			
<b>Typical Use</b>																			
Instrumentation																			
Oil-Air-Water																			
Refrigeration																			
Hydraulic Systems																			
Cooling Systems																			
Lubrication Systems																			
Air Brake																			

Recommendation and Applicability     
 A — Copper tubing (half or full hard) may be used     
 E — Use brass sleeve only     
 G — Cadmium Free Braze Ring  
 B — May be used if bundy is tin dipped     
 F — Available on special order     
 H — Available in most sizes

**Fitting Thread Size Comparison Chart** – The male connections have (Male unified thread class 2 fit) UN-2A specification threads and the female connections have (Female unified thread class 2 fit) UN-2B specification threads. The exceptions are male and female pipe threads.

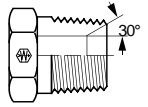
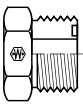
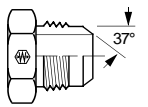
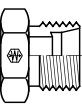
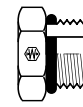
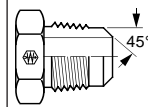
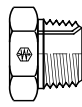
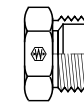
								
Size	Pipe Size	FOR-SEAL®	37° Flare Flare-Twin®	Ermeto® 7000 Series	Straight Thread O-Ring SAE	45° Flare	Inverted Flare	Compression
1/16	1/16-27	–	–	–	–	–	–	–
1/8	1/8-27	–	5/16-24	5/16-24	5/16-24	5/16-24	5/16-28	5/16-24
3/16	–	–	3/8-24	3/8-24	3/8-24	3/8-24	3/8-24	3/8-24
1/4	1/4-18	9/16-18	7/16-20	7/16-20	7/16-20	7/16-20	7/16-24	7/16-24
5/16	–	–	1/2-20	1/2-20	1/2-20	1/2-20	1/2-20	1/2-24
3/8	3/8-18	11/16-16	9/16-18	9/16-18	9/16-18	5/8-18	5/8-18	9/16-24
7/16	–	–	–	–	–	11/16-16	11/16-18	5/8-24
1/2	1/2-14	13/16-16	3/4-16	3/4-16	3/4-16	3/4-16	3/4-18	11/16-20
5/8	–	1-14	7/8-14	7/8-14	7/8-14	7/8-14	7/8-18	13/16-18
3/4	3/4-14	1-3/16-12	1-1/16-12	1-1/16-12	1-1/16-12	1-1/16-14	1-1/16-16	1-18
7/8	–	1-3/16-12	1-3/16-12	1-3/16-12	1-3/16-12	–	1-3/16-16	–
1	1-11-1/2	1-7/16-12	1-5/16-12	1-5/16-12	1-5/16-12	–	1-5/16-16	1-1/4-18
1-1/4	1-1/4-11-1/2	1-11/16-12	1-5/8-12	1-5/8-12	1-5/8-12	–	–	–
1-1/2	1-1/2-11-1/2	2-12	1-7/8-12	1-7/8-12	1-7/8-12	–	–	–
2	2-11-1/2	2-1/2-12	2-1/2-12	2-1/2-12	2-1/2-12	–	–	–

### ACTUAL PIPE THREAD SIZES

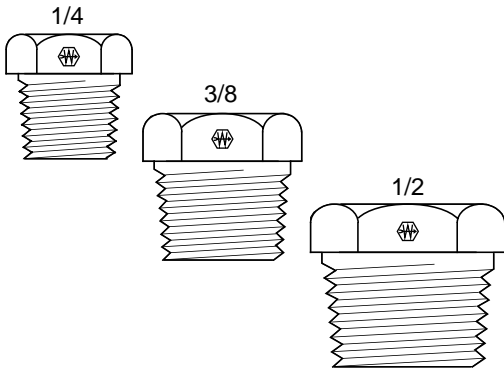

### PIPE FITTINGS

The Society of Automotive Engineers in cooperation with industry set up a standard for improvement in pipe threads. This improvement is known as the Dryseal Pipe Thread. All Weatherhead pipe threads are Dryseal American Standard Tapered Pipe Threads (NPTF). The metal to metal seal is formed by contact at the thread crest and root.

Nominal pipe sizes do not agree with either the I.D., O.D., or thread sizes. To determine pipe size (up to 1-1/4") measure the diameter of the threads and subtract 1/4". For example, subtract 1/4" from a 1" thread O.D. to obtain the nominal pipe size of 3/4".

### TUBE FITTINGS

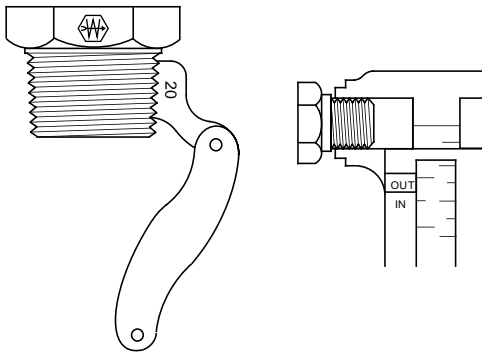

There are four basic types of tube fittings; Flare, Flareless, Straight Thread O-Ring, and Flat Face O-Ring Seal (FOR-SEAL®). Tube fittings seal in two ways. Flare and Flareless fittings use metal to metal contact joints. Straight Thread O-Ring and Flat Face O-Ring fittings use a rubber O-Ring. Where extreme vibration is present, use Flareless, Straight Thread or Flat Face O-Ring Seal fittings.

**SIZING:** For accuracy, it is recommended the male thread be measured. Measure the outside diameter. For our example use 7/16". Next measure the threads per inch, use 20. Our fitting size measures 7/16-20. Refer to the thread chart above for appropriate tube size and illustration.

Identifying metric, or non-USA, threaded connections is similar to identifying the connections that have been commonly used in the United States. The following text covers how to identify the different styles of metric connections offered by Weatherhead.

**THREADS** - The thread forms and their corresponding specifications listed below are used on all of the metric styles of connections which will be discussed later. These cover the basic forms of the threads but not the style of connection.

Thread Type	Specifications
British Parallel Pipe Threads	BS 2779, ISO/R 228
British Taper Pipe Threads	BS 21, ISO/R 7
Metric Parallel Threads	DIN 3852, ISO/R 6149
Metric Taper Threads	DIN 3852

**NOTE:** BS—British Standards Institution  
 ISO—International Standards Organization  
 DIN—Deutsche Industrie Norme

To identify metric connections, you will need instruments that can accurately measure thread inside and outside diameters, thread pitch and fitting seat angles. The TA-1002 Thread Measuring Guide and Tool Kit is a basic kit that will help you in identifying most of the connections you will be encountering on imported equipment.

**PARALLEL and TAPERED THREADS**

Parallel Threads ('G')

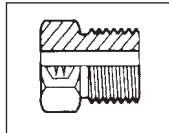

Figure 1.

Tapered Threads ('R')

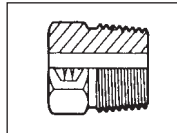

Figure 2.

The first step in identifying thread forms is to determine if the thread is parallel or tapered. Parallel threads are not used for sealing fluids. Sealing is achieved by an elastomeric o-ring, metal seal, machined ring into the hex itself or a seat machined into the end of the fitting. This style is similar to straight thread o-ring port connections where the threads are used for retention of the sealing method against a machine port. Parallel threads can be determined by laying a straight edge along the threads. If the threads are parallel to the center line of the fitting, then the fitting has parallel threads. See Figure 1.

Tapered threads seat by the interference caused by the male and female threads. These threads create a pressure-tight joint by metal deformation when they are tightened. Sealants on the threads are commonly used in this style of connection. Laying a straight edge on the threads, compare this line with the center line of the fitting. If this line tapers slightly away from the center line, then the threads are tapered. See Figure 2.

**BRITISH PIPE THREADS**

There are two forms of British Standard Pipe Threads that are used in the world today. They are BSPP (British Standard Pipe Parallel) and BSPT (British Standard Pipe Tapered). The BSPT male thread mates with the female BSPT thread similar to an NPTF connection. The 30° BSPP male adapters connect to a female BSPP thread with a 30° cone. This style is comparable to an NPSM swivel style. These threads are almost identical to the NPTF Pipe Thread except for the flank angle. This angle is 55° versus 60° on the NPTF. See Figure 3. Because of this difference, the two forms are **NOT** interchangeable.

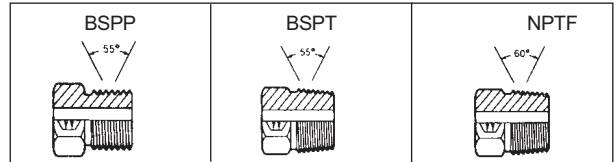

Figure 3.

Identifying BSP threads starts with determining if it is a parallel or tapered thread. Next, referencing Figure 4, measure the lead thread diameter. Compare this measurement to the listed dimensions to determine size. If instruments are not available to measure this, you can compare it end-to-end with a known NPTF thread to approximately arrive at the nominal BSP size. Finally, measure the pitch and compare it to the chart on Figure 4a to complete the identification. These dimensions will be the same for both BSPP and BSPT.

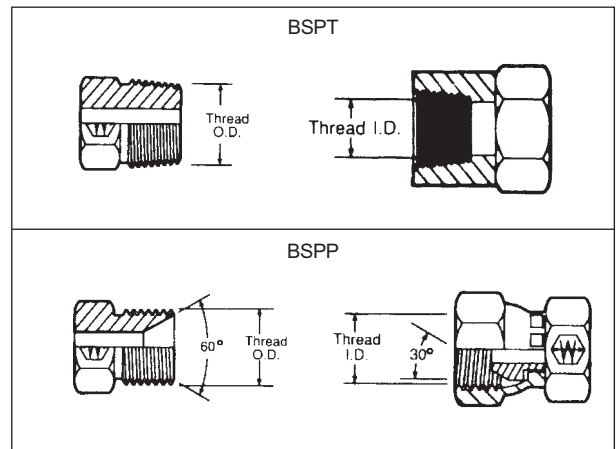

Figure 4.

BSP Thread Size	1/8-28	1/4-19	3/8-19	1/2-14	5/8-14	3/4-14	1-11	1-1/4-11	1-1/2-11	2-11
<b>Male Thread Diameter</b>	9.72 (.375)	13.16 (.518)	16.66 (.656)	20.96 (.825)	22.91 (.902)	26.44 (1.041)	33.25 (1.309)	41.91 (1.650)	47.80 (1.882)	59.51 2.347
<b>Female Thread Diameter</b>	8.73 (.343)	11.66 (.459)	15.37 (.605)	18.90 (.744)	20.85 (.821)	24.38 (.960)	30.61 (1.205)	39.24 (1.545)	45.24 (1.781)	55.94 2.242
<b>Pitch</b>	.91 (.036)	1.34 (.053)	1.34 (.053)	1.81 (.071)	1.81 (.071)	1.81 (.071)	2.31 (.091)	2.31 (.091)	2.31 (.091)	2.31 (.091)

**BSPP & BSPT Thread Chart**

Figure 4a. Dimension Note: MM(IN)

See page 225 for Thread Measuring Kits.

## METRIC THREADS

Metric threads are similar to inch-sized threads except for the sizing which is based on standard metric units. Identifying metric threads starts with determining if it is a parallel or tapered thread. Next, measure the thread diameter. Compare this measurement to the dimensions listed in Figure 5 to determine size. Finally, measure the pitch and compare to chart. These dimensions will be common for both parallel and tapered threads.

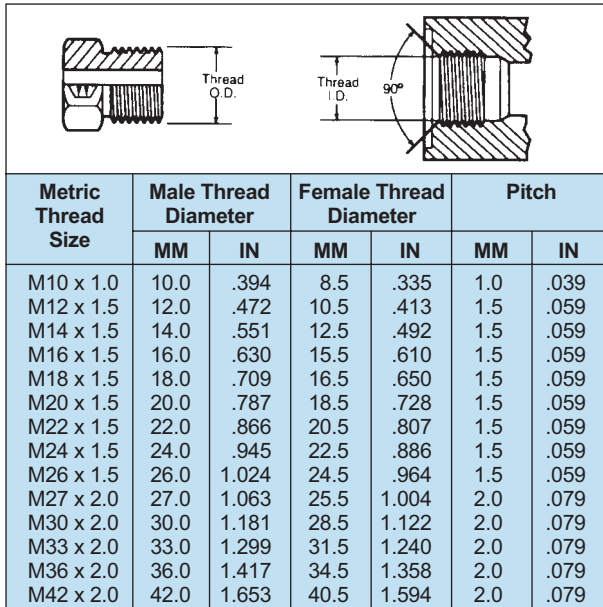

Figure 5.

## METRIC FLARELESS CONNECTIONS—Din 3901/3902L, 3901/3902S

The most popular metric flareless, or bite-type, fitting style is the 24° Metric Tube Seat. This style incorporates a tapered seat in the fitting body with a bite-type sleeve, or ferrule, for the connection. When the nut is tightened, the tapered seat forces the sleeve into the tube creating a positive seal. This style of connection is available in both a Light and Heavy series and is designed for medium and high pressure applications respectively. The two series have different parallel thread sizes in relationship to the nominal tube outside diameter, but share a common sleeve. This style can be identified by the combination of the 24° internal seat and a male metric parallel thread. The series can be determined by measuring the seat counterbore, which is the approximate tube outside diameter, and comparing it to the thread size. Compare these dimensions to those shown in Figure 6 to determine the series. The nominal sleeve size is taken directly from the tube outside diameter dimension.

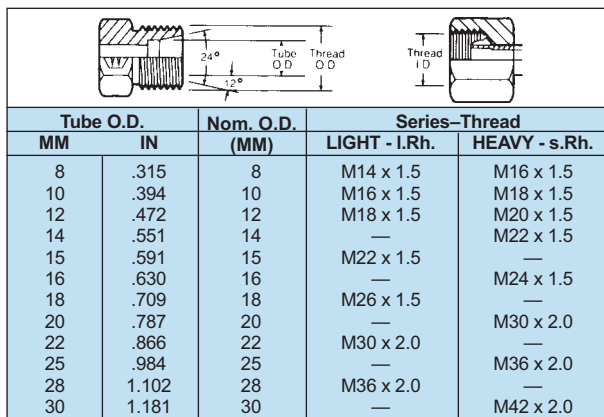

Figure 6.

## METRIC 60° TUBE SEAT—DIN 7631

This series combines an internal 60° seat with parallel metric Light series threads. Mating with female metric swivel fittings with a globe seal made to DIN 3863L, this connection provides a metal to metal seal when tightened. This style can be identified by the internal 60° seat on the male metric threaded portion. Reference Figure 7 for thread information.

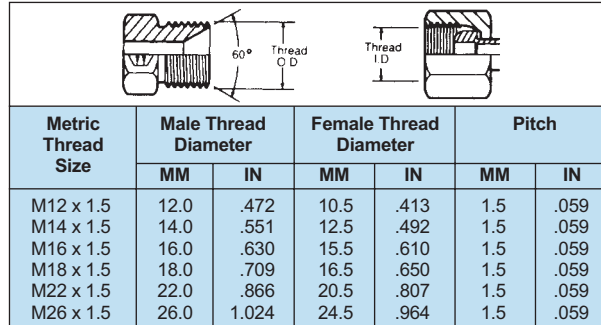

Figure 7.

## JAPANESE METRIC 30° FLARE

The Japanese 30° flare style is similar to the 37° JIC flare connection except for two things. The seat angle is 30° and threads are metric straight threads. This fitting is often referred to as a 'Komatsu' style connection. To identify this style, first verify the seat angle is 30°. Next establish the metric thread size by measuring the thread outside diameter. Compare this dimension to those shown in Figure 8. The threads in this series will conform to Japanese Industrial Standard (JIS) B 0207.

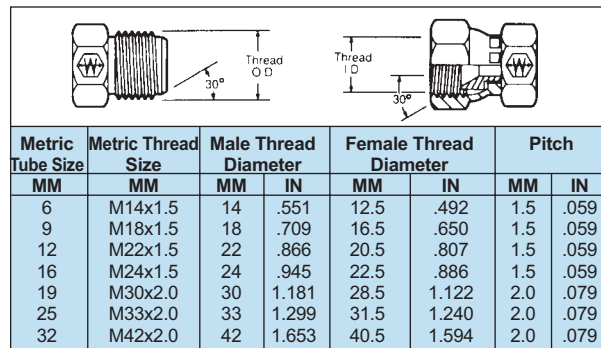

Figure 8.

## JAPANESE 30° FLARE (JIS)

Similar to BSPP and a 30° seat. The seal is made when contact is made between the male and female flares, with the threads retaining the connection. The JIS 30° flare is similar to the 37° flare connection. To determine the difference between the JIS 30° flare and the JIC 37° flare, carefully measure the seat angle. The threads in this series conform to Japanese Industrial Standard (JIS) B 0202.

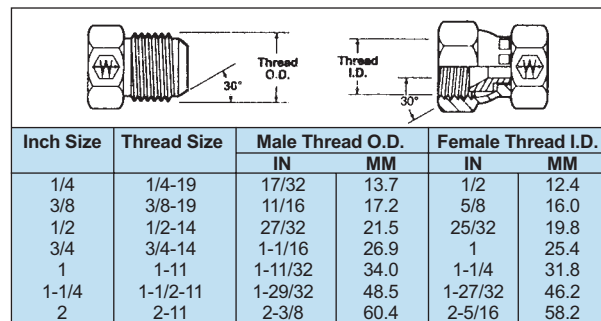



Figure 9.

See page 261 for Thread Measuring Kits.

 Refer to safety information regarding tubing selection on page 1.

To select tubing for a particular installation, two factors must be determined...

- 1.) **tubing type** - material and construction and
- 2.) **size** - inside diameter (I.D.) and wall thickness. Information listed below will aid in your tubing selection.

### TUBING TYPES

Commercial tubing is available in a wide variety of materials, types of construction and quality. Each is best suited for certain specific applications.

**STEEL TUBING** - Seamless SAE 1010 fully annealed and SAE welded types suitable for bending and flaring. This is the only tubing material approved without restrictions by SAE standards.

**STAINLESS STEEL TUBING** - Both seamless \*18-8 fully annealed and welded types suitable for bending and flaring. Stainless steel tubing is recommended for use with very high pressures and where large diameter tubing is required. It is also suited for many applications where corrosion is a problem.

\* (302, 303 and/or 304)

**ALUMINUM TUBING** - Seamless annealed is approved by SAE for low pressure applications.

**COPPER TUBING** - Seamless fully annealed coils and fully annealed or quarter-hard straight lengths can be used for systems that do not use petroleum based fluids (copper acts as an oil-oxidation catalyst, causing sludge). Copper also tends to work harden when flared or bent and has poor resistance to vibration. Therefore, the use of copper tubing is limited to low-pressure stationary applications and air circuits.

**SPECIAL ALLOY TUBING** - May be required for specific corrosion problems. Information on these applications can be obtained from your tubing supplier or from tubing manufacturers.

### TUBING SIZE

The two variables in tubing size are the inside diameter (ID) and the wall thickness. Each of these is dependent upon a number of factors.

**INSIDE DIAMETER** - The tubing I.D. will determine the flow and velocity of the fluid in the system.

Flow is the volume of fluid that is to be moved through the line to perform a given job within a specified time. Flow rate is expressed in gallons per minute (gpm).

Velocity is the rate of speed at which the fluid passes through the line. It is expressed in feet per second (fps). With a given flow rate, the velocity will increase as the inside diameter of the tubing decreases.

**To determine the appropriate tubing I.D. for specific flow rate and velocity, refer to the Velocity vs. Flow chart on page 21.**

**WALL THICKNESS** - The required wall thickness of the tubing depends upon operating pressure, safety factor, temperatures, and tubing material.

Operating Pressure is the pressure of the fluid in the system. It is expressed in pounds per square inch (psi).

Safety Factor is a multiplier applied to the wall thickness that compensates for additional mechanical strains and hydraulic shocks to which the tubing may be subjected during operation.

**To determine the appropriate wall thickness, refer to the data on pages 22 and 23.**

### PRESSURE DROP

Total pressure supplied to a line must equal usable pressure (or output) plus the pressure that is lost through fluid transmission, which is referred to as pressure drop. These pressure drops cause loss of energy and should be kept to a minimum. Elements which cause pressure drop in the transmission of fluids include sudden enlargements or contractions, bends, fittings and valves.

Mathematical analysis of pressure drop, although possible, is not precise because of the interrelationship of factors such as fluid velocity, density, flow area and friction coefficients. Therefore, to obtain optimum efficiency, the system (or the questionable portions of the system) should be mocked-up to obtain empirical pressure drop data.

 Refer to safety information regarding tubing selection on page 1.

Following is a typical problem that illustrates, step by step, the procedure for determining tube size.

Select 1010 steel tubing with the appropriate I.D. and wall thickness for the following conditions:

- Flow — 5 gpm
- Velocity — not to exceed 10 fps
- Pressure — 2000 psi
- Safety Factor — 4:1

**SOLUTION:**

1. Using the Flow/Velocity chart on Page 21, follow the horizontal flow line (5 gpm) until it intersects the vertical velocity line (10fps). From this point, follow the diagonal line upward to get the required tube I.D. (.444). If the horizontal flow line and the vertical velocity line intersect between two diagonal lines, normally the larger inside diameter would be selected since it would mean less velocity.
2. Refer to the chart of Standard Size Hydraulic Tubing, at right. Note that .444 I.D. tubing is not listed. If you want to use standard tubing, select one with a larger I.D. Do not select a smaller size since this would increase the velocity to over the 10 fps limit. Therefore, by going to the next largest size, you would select the 5/8" O.D. tubing having an I.D. of .459 and a wall thickness of .083.
3. To determine whether this tubing will meet the pressure and safety factor requirements, refer to the Recommended Wall Thickness data on pages 24 and 25. For 5/8" O.D. tubing at 2000 psi, the chart for 1010 steel indicates that the minimum wall thickness with a safety factor of 4:1 is .04545. Since you have selected a tubing with a .083 wall, this would easily fulfill the requirements. However, for savings on weight and cost, you can select another tubing with a thinner wall that will still meet the performance requirements. Therefore, refer again to the chart on standard size tubing and select a tubing with a wall thickness closer to the minimum requirements. This would be the 5/8" O.D. tubing with a .527 I.D. and a .049 wall. This tubing will handle the pressure requirements of 2000 psi with a safety factor of 4:1, and also provides the required flow while keeping the velocity within the 10 fps limitation.

**STANDARD SIZE HYDRAULIC TUBING**

Tube O.D.	Tube I.D.	Wall	Tube O.D.	Tube I.D.	Wall
1/8"	.055	.035	3/4"	.584	.083
	.061	.032		.606	.072
	.065	.030		.620	.065
3/16"	.069	.028	7/8"	.634	.058
	.117	.035		.652	.049
	.123	.032		.680	.035
1/4"	.127	.030	1"	.657	.109
	.120	.065		.685	.095
	.134	.058		.709	.083
	.152	.049		.731	.072
	.166	.042		.745	.065
5/16"	.180	.035	1-1/4"	.759	.058
	.190	.030		.777	.049
	.182	.065		.982	.134
	.196	.058		1.010	.120
	.214	.049		1.032	.109
3/8"	.228	.042	1-1/2"	1.060	.095
	.242	.035		1.084	.083
	.248	.032		1.106	.072
	.245	.065		1.120	.065
	.259	.058		1.134	.058
1/2"	.277	.049	2"	1.152	.049
	.291	.042		1.232	.134
	.305	.035		1.260	.120
	.311	.032		1.282	.109
	.310	.095		1.310	.095
5/8"	.334	.083	3"	1.334	.083
	.358	.072		1.356	.072
	.370	.065		1.370	.065
	.384	.058		1.732	.134
	.402	.049		1.760	.120
3/4"	.416	.042	3-1/4"	1.782	.109
	.430	.035		1.810	.095
	.436	.032		1.834	.083
	.435	.095		1.856	.072
	.459	.083		1.870	.065
1"	.481	.072	3-1/2"	1.870	.065
	.495	.065		1.870	.065
	.509	.058		1.870	.065
	.527	.049		1.870	.065
	.541	.042		1.870	.065
3/4"	.555	.035	3-3/4"	1.870	.065
	.532	.109		1.870	.065
1-1/8"	.560	.095	4"	1.870	.065
	.560	.095		1.870	.065

### TO FIND REQUIRED TUBE I.D.

**Flow—20 gpm • Velocity—9 fps**  
 Follow horizontal flow line (20 gpm) until it intersects vertical velocity line (9 fps). From this point follow diagonal line to get required Tube I.D. —(.944).

### TO FIND PERMISSIBLE FLOW

**Velocity—15 fps • Tube I.D.—.495**  
 Follow vertical velocity line (15 fps) until it intersects diagonal line representing .495 tube I.D. Then project this point horizontally to get the permissible flow—(9 gpm).

### TO FIND VELOCITY OF FLUID IN SYSTEM

**Flow—6 gpm • Tube I.D.—.694**  
 Follow horizontal flow line (6 gpm) until it intersects diagonal line representing .694 tube I.D. Then project this point vertically downward to get the velocity of fluid —(5 fps).

## FLOW/VELOCITY CHART

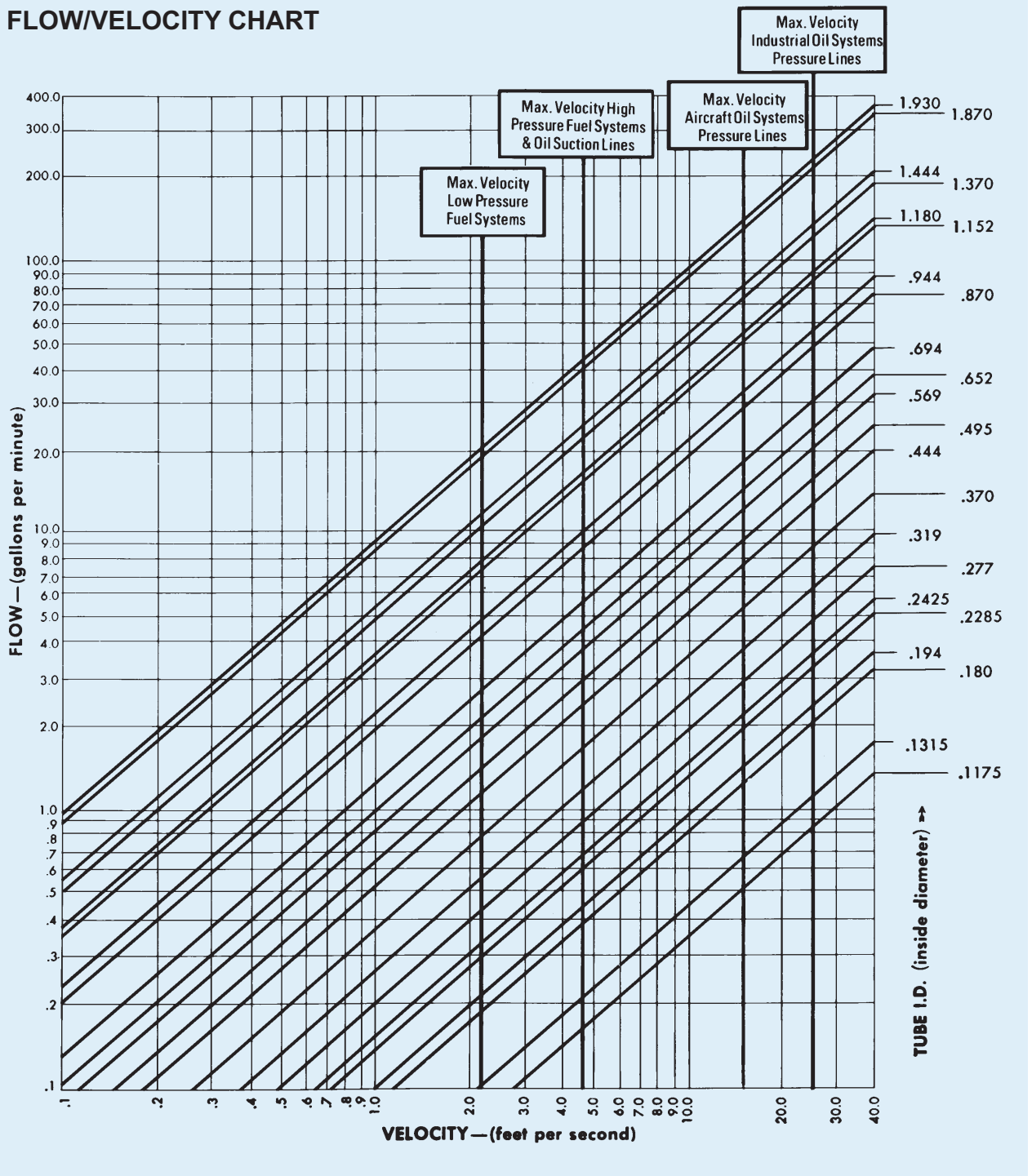

 Refer to safety information regarding tubing selection on page 1.

With the following Recommended Wall Thickness tables the tubing wall can be selected that is best suited for a particular application. The data given in these tables are raw figures based on the equation –

$$t = \frac{Dp(FS)}{2S}$$

- t–wall thickness (inches)
- D–O.D. of tube (inches)
- p–pressure (psi)
- FS–Safety Factor
- S–tensile strength of tubing material

Therefore, many of the wall thicknesses given in these tables are not found on standard tubing, but serve to establish the minimum wall required.

**SAFETY FACTOR** – The standard safety factors indicate three grades of severity of service:

**4:1** –mechanical and hydraulic shocks not excessive

**6:1** –considerable mechanical strain and hydraulic shock

**8:1** –hazardous applications with severe service conditions

### RECOMMENDED WALL THICKNESS TABLES

1010 STEEL Based on 55,000#/in. <sup>2</sup> Strength (F S=4)					
TUBE O.D.	working pressure (psi)				
	1,000	2,000	3,000	4,000	5,000
1/8	.00455	.00909	.01364	.01818	.02273
3/16	.00682	.01364	.02045	.02727	.03409
1/4	.00909	.01818	.02727	.03636	.04545
5/16	.01136	.02273	.03409	.04545	.05682
3/8	.01364	.02727	.04091	.05455	.06818
1/2	.01818	.03636	.05455	.07273	.09091
5/8	.02273	.04545	.06818	.09091	.11364
3/4	.02727	.05455	.08182	.10909	.13636
7/8	.03182	.06364	.09545	.12727	.15909
1	.03636	.07273	.10909	.14545	.18182
1-1/4	.04545	.09091	.13636	.18182	.22727
1-1/2	.05455	.10909	.16364	.21818	.27273
2	.07273	.14545	.21818	.29091	.36364

4130 STEEL Based on 90,000#/in. <sup>2</sup> Strength (F S=4)					
TUBE O.D.	working pressure (psi)				
	1,000	2,000	3,000	4,000	5,000
1/8	.00278	.00556	.00833	.01111	.01389
3/16	.00417	.00833	.01250	.01667	.02083
1/4	.00556	.01111	.01667	.02222	.02778
5/16	.00694	.01389	.02083	.02778	.03472
3/8	.00833	.01667	.02499	.03333	.04167
1/2	.01111	.02222	.03333	.04444	.05556
5/8	.01389	.27778	.04167	.05556	.06944
3/4	.01667	.03333	.04999	.06667	.08333
7/8	.01944	.03889	.05833	.07778	.09722
1	.02222	.04444	.06667	.08889	.11111
1-1/4	.02778	.05556	.08333	.11111	.13889
1-1/2	.03333	.06667	.09999	.13333	.16667
2	.04444	.08889	.13333	.17778	.22222

The wall thickness shown in these tables are based on ultimate strength of material and a safety factor of 4:1.

To obtain the recommended wall for a specific pressure based on a safety factor of 6:1, multiply the wall thickness indicated in the table by 1.5. For a safety factor of 8:1, multiply by 2:

**TEMPERATURE** – The wall thickness found by using these tables can be corrected for temperature by multiplying the wall thickness by the appropriate correction factor given in the chart below. The table is based on strength reduction due to increased temperature.

### RECOMMENDED WALL THICKNESS TABLES

Temperature	1010 Steel	Stainless Steel	Copper	Aluminum
+100F.	1.00	1.00	1.00	1.00
+200F.	1.00	1.00	1.08	1.00
+300F.	1.00	1.00	1.22	1.08
+400F.	1.00	1.00	2.30	1.41
+500F.	1.00	1.00	–	2.10
+600F.	1.00	1.00	–	–
+700F.	1.00	1.00	–	–
+800F.	1.08	1.07	–	–
+900F.	1.32	1.13	–	–
+1000F.	1.66	1.22	–	–

1020 STEEL Based on 65,000#/in. <sup>2</sup> Strength (F S=4)					
TUBE O.D.	working pressure (psi)				
	1,000	2,000	3,000	4,000	5,000
1/8	.00385	.00790	.01154	.01538	.01923
3/16	.00577	.01154	.01731	.02308	.02885
1/4	.00769	.01538	.02308	.03077	.03846
5/16	.00962	.01923	.02885	.03846	.04808
3/8	.01154	.02308	.03462	.04615	.05769
1/2	.01538	.03077	.04615	.06154	.07692
5/8	.01923	.03846	.05769	.07692	.09615
3/4	.02308	.04615	.06923	.09231	.11538
7/8	.02692	.05385	.08077	.10769	.13462
1	.03077	.06154	.09231	.12308	.15385
1-1/4	.03846	.07692	.11538	.15385	.19231
1-1/2	.04615	.09231	.13846	.18462	.23077
2	.06154	.12308	.18462	.24615	.30769

BUNDYWELD Based on 42,000#/in. <sup>2</sup> Strength (F S=4)					
TUBE O.D.	working pressure (psi)				
	1,000	2,000	3,000	4,000	5,000
1/8	.00595	.01190	.01786	.02381	.02976
3/16	.00893	.01786	.02679	.03571	.04464
1/4	.01190	.02381	.03571	.04762	.05952
5/16	.01488	.02976	.04464	.05952	.07440
3/8	.01786	.03571	.05357	.07143	.08929
1/2	.02381	.04762	.07143	.09524	.11905
5/8	.02976	.05952	.08929	.11905	.14881
3/4					
1					
1-1/4					
1-1/2					
2					



# Tubing Selection

## Application

 Refer to safety information regarding tubing selection on page 1.

APPLICATION

TUBE O.D.	STAINLESS STEEL (304) ANNEALED BASED ON 75,000#/IN. <sup>2</sup> STRENGTH (F.S. -4)					STAINLESS STEEL (304) ANNEALED BASED ON 105,000#/IN. <sup>2</sup> STRENGTH (F.S. -4)				
	working pressure (psi)					working pressure (psi)				
	1,000	2,000	3,000	4,000	5,000	1,000	2,000	3,000	4,000	5,000
1/8	.00333	.00666	.00999	.01333	.01666	.00238	.00476	.00714	.00952	.01190
3/16	.00499	.00999	.01498	.01999	.02499	.00357	.00714	.01071	.01429	.01786
1/4	.00666	.01332	.01998	.02667	.03333	.00476	.00952	.01429	.01905	.02381
5/16	.00833	.01665	.02497	.03333	.04165	.00595	.01190	.01786	.02381	.02976
3/8	.0099	.01998	.02997	.03999	.04998	.00714	.01429	.02143	.02857	.03571
1/2	.01332	.02664	.03996	.05333	.06664	.00957	.01904	.02857	.03810	.04762
5/8	.01665	.03333	.04995	.06666	.08330	.01190	.02381	.03571	.04762	.05952
3/4	.01998	.03996	.05994	.07999	.09996	.01429	.02857	.04286	.05714	.07143
7/8	.02331	.04662	.06996	.09333	.11662	.01667	.03333	.05000	.06666	.08333
1	.02664	.05328	.07992	.10666	.13328	.01904	.03810	.05714	.07619	.09524
1-1/4	.03333	.06666	.09999	.13333	.16666	.02381	.04762	.07143	.09524	.11905
1-1/2	.03996	.07992	.11988	.15999	.19992	.02857	.05714	.08371	.11429	.14286
2	.05328	.10656	.15984	.21333	.26666	.03810	.07619	.11428	.15238	.19048

TUBE O.D.	ANNEALED COPPER BASED ON 30,000#/IN. <sup>2</sup> STRENGTH (F.S. -4)					COPPER (UNS C12200 LIGHT DRAWN) BASED ON 40,000#/IN. <sup>2</sup> STRENGTH (F.S. -4)				
	working pressure (psi)					working pressure (psi)				
	1,000	2,000	3,000	4,000	5,000	1,000	2,000	3,000	4,000	5,000
1/8	.00833	.01667	.02500	.03333	.04167	.00625	.01250	.01875	.02500	.03125
3/16	.01250	.02499	.03750	.04999	.06250	.00938	.01875	.02812	.03750	.04688
1/4	.01667	.03333	.05000	.06666	.08333	.01250	.02500	.03750	.05000	.06250
5/16	.02083	.04167	.06250	.08333	.10417	.01562	.03125	.04688	.06250	.07812
3/8	.02499	.04999	.07500	.09999	.12499	.01875	.03750	.05625	.07500	.09375
1/2	.03333	.06667	.10000	.13333	.16667	.02500	.05000	.07500	.10000	.12500
5/8	.04167	.08333	.12500	.16666	.20883	.03125	.06250	.09375	.12500	.15625
3/4	.04999	.09999	.15000	.19999	.24999	.03750	.07500	.11250	.15000	.18750
7/8	.05833	.11667	.17500	.23333	.29166	.04375	.08750	.13125	.17500	.21875
1	.06667	.13333	.20000	.26666	.33333	.05000	.10000	.15000	.20000	.25000
1-1/4	.08333	.16667	.25000	.33333	.41667	.06250	.12500	.18750	.25000	.31250
1-1/2	.09999	.19999	.30000	.39999	.49999	.07500	.15000	.22500	.30000	.37500
2	.13333	.26667	.40000	.53333	.66667	.10000	.20000	.30000	.40000	.50000

TUBE O.D.	ALUMINUM 3003 (H-14) BASED ON 20,000#/IN. <sup>2</sup> STRENGTH (F.S. -4)					ALUMINUM 5052 (H-32) BASED ON 31,000#/IN. <sup>2</sup> STRENGTH (F.S. -4)				
	working pressure (psi)					working pressure (psi)				
	1,000	2,000	3,000	4,000	5,000	1,000	2,000	3,000	4,000	5,000
1/8	.01250	.02500	.3750	.05000		.00806	.01613	.02419	.03226	.04032
3/16	.01875	.03750	.05650	.07500		.01210	.02419	.03629	.04839	.06048
1/4	.02500	.05000	.07500	.10000		.01613	.03226	.04839	.06452	.08065
5/16	.03125	.06250	.09375	.12500		.02016	.04032	.06048	.08065	.10081
3/8	.03750	.07500	.11250	.15000		.02419	.04839	.07258	.09677	.12097
1/2	.05000	.10000	.15000	.20000		.03227	.06452	.09677	.12903	.16129
5/8	.06250	.12500	.18750	.25000		.04032	.08065	.12097	.16129	.20161
3/4	.07500	.15000	.22500	.30000		.04839	.09677	.14516	.19355	.24194
7/8	.08750	.17500	.26250	.35000		.05645	.11290	.16935	.22581	.28226
1	.10000	.20000	.30000	.40000		.06452	.12903	.19355	.25806	.32258
1-1/4	.12500	.25000	.37500	.50000		.08065	.16129	.24194	.32258	.40323
1-1/2	.15000	.30000	.45000	.60000		.09677	.19355	.29032	.38710	.48387
2	.20000	.40000	.60000	.80000		.12903	.25806	.38710	.51613	.64516

TUBE O.D.	CUPRO-NICKEL 30% BASED ON 52,000#/IN. <sup>2</sup> STRENGTH (F.S. -4)				
	working pressure (psi)				
	1,000	2,000	3,000	4,000	5,000
1/8	.00481	.00962	.01442	.01923	.02404
3/16	.00721	.01442	.02163	.02885	.03606
1/4	.00962	.01923	.02885	.03846	.04808
5/16	.01202	.02404	.03606	.04808	.06010
3/8	.01442	.02885	.04327	.05769	.07212
1/2	.01923	.03846	.05769	.07692	.09615
5/8	.02404	.04808	.07212	.09615	.12019
3/4	.02885	.05769	.08654	.11538	.14423
7/8	.03365	.06731	.10096	.13462	.16827
1	.03846	.07692	.11538	.15385	.19231
1-1/4	.04808	.09615	.14423	.19231	.24038
1-1/2	.05769	.11538	.17308	.23077	.28846
2	.07692	.15385	.23077	.30769	.38462

 **SHADED AREAS**

Tubing wall thickness listed in the shaded areas are generally either too light or too heavy for practical applications, and are listed only to provide data for accurate computation.

 Refer to safety information regarding tubing selection on page 1.

These tables provide data on required wall thickness for various sizes and pressures, and when to use flared or flareless fittings. Although heavier wall tubing can be ordered for higher operating pressures, only standard size hydraulic tubing is listed in these tables.

High temperature effects are not considered in these tables.

### 1010 STEEL TUBING WALL THICKNESS

TUBE O.D.	4:1 SAFETY FACTOR					6:1 SAFETY FACTOR					8:1 SAFETY FACTOR				
	working pressure (psi)					working pressure (psi)					working pressure (psi)				
	1,000	2,000	3,000	4,000	5,000	1,000	2,000	3,000	4,000	5,000	1,000	2,000	3,000	4,000	5,000
1/8	.028	.028	.028	.028	.028	.028	.028	.028	.028	.035	.028	.028	.028	.035	—
3/16	.030	.030	.030	.030	.035	.030	.030	.030	—	—	.030	.030	—	—	—
1/4	.030	.030	.030	.042	.049	.030	.030	.042	.058	—	.030	.035	.058	—	—
5/16	.032	.032	.035	.049	.058	.032	.032	.058	.065	—	.032	.049	.065	—	—
3/8	.032	.032	.042	.058	—	.032	.042	.058	—	—	.032	.058	—	—	—
1/2	.032	.042	.058	.072	—	.032	.058	.083	—	—	.042	.072	—	—	—
5/8	.035	.049	.072	.095	—	.035	.072	—	—	—	.049	.095	—	—	—
3/4	.035	.058	.083	.109	—	.049	.083	—	—	—	.058	.109	—	—	—
7/8	.049	.065	.095	—	—	.049	.095	—	—	—	.065	—	—	—	—
1	.049	.072	.109	—	—	.058	.109	—	—	—	.072	—	—	—	—
1-1/4	.049	.095	—	—	—	.072	—	—	—	—	.095	—	—	—	—
1-1/2	.065	.109	—	—	—	.083	—	—	—	—	.109	—	—	—	—
2	.072	—	—	—	—	.109	—	—	—	—	—	—	—	—	—

### 1020 STEEL TUBING WALL THICKNESS

TUBE O.D.	4:1 SAFETY FACTOR					6:1 SAFETY FACTOR					8:1 SAFETY FACTOR				
	working pressure (psi)					working pressure (psi)					working pressure (psi)				
	1,000	2,000	3,000	4,000	5,000	1,000	2,000	3,000	4,000	5,000	1,000	2,000	3,000	4,000	5,000
1/8	.028	.028	.028	.028	.028	.028	.028	.028	.028	.030	.028	.028	.028	.030	—
3/16	.030	.030	.030	.030	.030	.030	.030	.030	.035	—	.030	.030	.035	—	—
1/4	.030	.030	.030	.030	.042	.030	.030	.035	.049	.058	.030	.030	.049	—	—
5/16	.032	.032	.032	.042	.049	.032	.032	.042	.058	—	.032	.042	.058	—	—
3/8	.032	.032	.035	.049	.058	.032	.035	.058	.065	—	.032	.049	—	—	—
1/2	.032	.032	.049	.065	.083	.032	.049	.072	—	—	.032	.065	—	—	—
5/8	.035	.042	.058	.083	—	.035	.058	.095	—	—	.042	.083	—	—	—
3/4	.035	.049	.072	.095	—	.035	.072	.109	—	—	.049	.095	—	—	—
7/8	.049	.058	.083	—	—	.049	.083	—	—	—	.058	.109	—	—	—
1	.049	.065	.095	—	—	.049	.095	—	—	—	.065	—	—	—	—
1-1/4	.049	.083	.120	—	—	.058	.120	—	—	—	.083	—	—	—	—
1-1/2	.065	.095	—	—	—	.072	—	—	—	—	.095	—	—	—	—
2	.065	—	—	—	—	.095	—	—	—	—	.134	—	—	—	—

 Both SAE 37° SINGLE FLARE FLARE-TWIN or ERMETO® flareless recommended.

 ERMETO® flareless only.

**NOTE:** Only Weatherhead Ermeto flareless fittings can be used with high pressure, heavy wall tubing which is impractical to flare.

# Tubing Selection

Application

 Refer to safety information regarding tubing selection on page 1.

These tables provide data on required wall thickness for various sizes and pressures, and when to use flared or flareless fittings. Although heavier wall tubing can be ordered for higher operating pressures, only standard size hydraulic tubing is listed in these tables.

High temperature effects are not considered in these tables.

APPLICATION

## STAINLESS STEEL (304) ANNEALED TUBING WALL THICKNESS

TUBE O.D.	4:1 SAFETY FACTOR					6:1 SAFETY FACTOR					8:1 SAFETY FACTOR				
	working pressure (psi)					working pressure (psi)					working pressure (psi)				
	1,000	2,000	3,000	4,000	5,000	1,000	2,000	3,000	4,000	5,000	1,000	2,000	3,000	4,000	5,000
1/8	.028	.028	.028	.028	.028	.028	.028	.028	.028	.035	.028	.028	.028	.028	.035
3/16	.030	.030	.030	.030	.030	.030	.030	.030	.030	.035	.030	.030	.030	.030	—
1/4	.030	.030	.030	.030	.035	.030	.030	.030	.042	.058	.030	.030	.035	.058	.065
5/16	.032	.032	.032	.035	.042	.032	.032	.035	.058	.065	.032	.032	.049	.065	—
3/8	.032	.032	.032	.042	.058	.032	.042	.065	.083	—	.032	.042	.058	—	—
1/2	.032	.032	.042	.058	.072	.032	.042	.065	.083	—	.032	.058	.083	—	—
5/8	.035	.035	.058	.072	.083	.035	.058	.083	.095	—	.035	.065	—	—	—
3/4	.035	.049	.065	.083	.109	.035	.065	.095	—	—	.049	.083	—	—	—
7/8	.049	.049	.072	.095	—	.049	.072	.109	—	—	.049	.095	—	—	—
1	.049	.058	.083	.109	—	.049	.083	.120	—	—	.058	.109	—	—	—
1-1/4	.049	.072	.109	—	—	.058	.109	—	—	—	.065	.134	—	—	—
1-1/2	.065	.083	.120	—	—	.065	.120	—	—	—	.083	—	—	—	—
2	.065	.109	—	—	—	.083	—	—	—	—	.109	—	—	—	—

## STAINLESS STEEL (304) 1/8 HARD TUBING WALL THICKNESS

TUBE O.D.	4:1 SAFETY FACTOR					6:1 SAFETY FACTOR					8:1 SAFETY FACTOR				
	working pressure (psi)					working pressure (psi)					working pressure (psi)				
	1,000	2,000	3,000	4,000	5,000	1,000	2,000	3,000	4,000	5,000	1,000	2,000	3,000	4,000	5,000
1/8	.028	.028	.028	.028	.028	.028	.028	.028	.028	.028	.028	.028	.028	.028	.028
3/16	.030	.030	.030	.030	.030	.030	.030	.030	.030	.030	.030	.030	.030	.030	.035
1/4	.030	.030	.030	.030	.030	.030	.030	.030	.030	.035	.030	.030	.030	.042	.049
5/16	.032	.032	.032	.032	.032	.032	.032	.032	.035	.049	.032	.032	.035	.049	.058
3/8	.032	.032	.032	.032	.042	.032	.032	.032	.042	.058	.032	.032	.042	.058	—
1/2	.032	.032	.032	.042	.049	.032	.032	.042	.058	.072	.032	.042	.058	.083	—
5/8	.035	.035	.042	.049	.065	.035	.035	.058	.072	.095	.035	.049	.072	.095	—
3/4	.035	.035	.049	.058	.072	.035	.049	.065	.095	.109	.035	.058	.095	—	—
7/8	.049	.049	.058	.072	.083	.049	.058	.083	.109	—	.049	.065	.109	—	—
1	.049	.049	.058	.083	.095	.049	.058	.095	—	—	.049	.072	—	—	—
1-1/4	.049	.049	.072	.095	.120	.049	.072	.109	—	—	.049	.095	—	—	—
1-1/2	.065	.065	.095	—	—	.065	.095	—	—	—	.065	—	—	—	—
2	.065	.083	.120	—	—	.065	—	—	—	—	.083	—	—	—	—

 Both SAE 37° SINGLE FLARE FLARE-TWIN or ERMETO® flareless recommended.

 ERMETO® flareless only.

**NOTE:** Only Weatherhead Ermeto flareless fittings can be used with high pressure, heavy wall tubing which is impractical to flare.

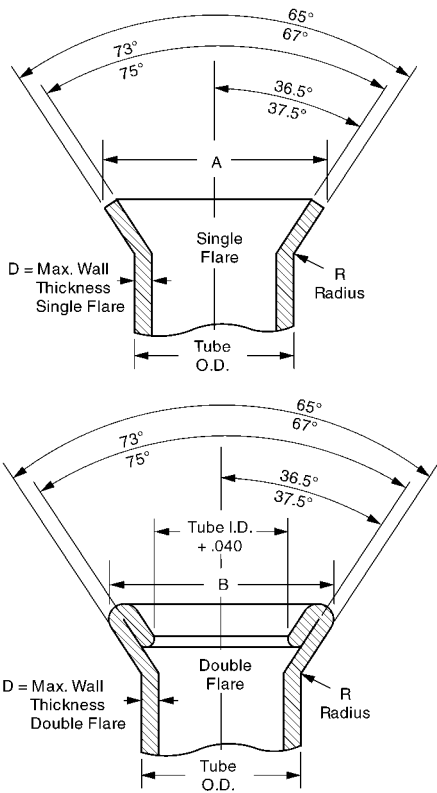

## SAE 37° FLARE TUBES

Tube Size O.D.	Single Flare A Diameter		Double Flare B Diameter		R Radius ±.020	Maximum Wall Thickness	
	Max.	Min.	Max.	Min.		Single Flare D	Double Flare D <sub>1</sub>
1/8	.200	.180	.200	.180	.030	.035	.025
3/16	.280	.260	.280	.260	.030	.035	.028
1/4	.360	.340	.360	.340	.030	.065	.035
5/16	.430	.400	.430	.400	.030	.065	.035
3/8	.490	.460	.490	.460	.040	.065	.049
1/2	.660	.630	.660	.630	.060	.083	.049
5/8	.790	.760	.790	.760	.060	.083	.049
3/4	.950	.920	.960	.920	.080	.109	.049
7/8	1.070	1.040	1.070	1.040	.080	.109	.065
1	1.200	1.170	1.200	1.170	.090	.120	.065
1 1/4	1.510	1.480	1.510	1.480	.090	.120	.065
1 1/2	1.730	1.700	1.730	1.700	.110	.120	.065
2	2.360	2.330	2.360	2.330	.110	.134	.065

## SAE 45° FLARE TUBE

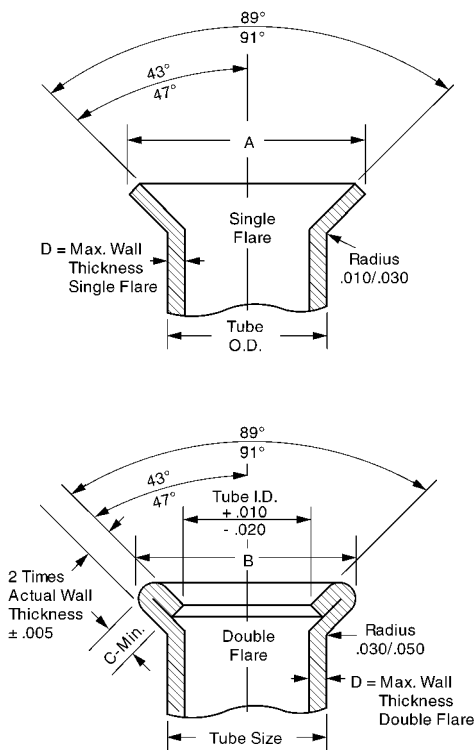

Tube Size	Single Flare A Diameter	Double Flare B Diameter	Double Flare Coined Seat Length C	Maximum	
				Single Flare D	Double Flare D <sub>1</sub>
1/8	.171/ .181	.198/ .213	.040	.035	.025
3/16	.239/ .249	.265/ .280	.040	.035	.028
1/4	.315/ .325	.345/ .360	.040	.049	.035
5/16	.388/ .404	.410/ .425	.062	.049	.035
3/8	.471/ .487	.485/ .500	.062	.065	.049
7/16	.545/ .561	.555/ .570	.062	.065	.049
1/2	.607/ .623	.625/ .640	.062	.083	.049
9/16	.660/ .676	.697/ .712	.062	.083	.049
5/8	.732/ .748	.757/ .772	.062	.095	.049
3/4	.900/ .916	.897/ .912	.062	.109	.049
7/8	1.025/ 1.041	—	—	.109	—
1	1.141/ 1.157	—	—	.120	—

 Refer to safety information regarding tubing installation on page 2.

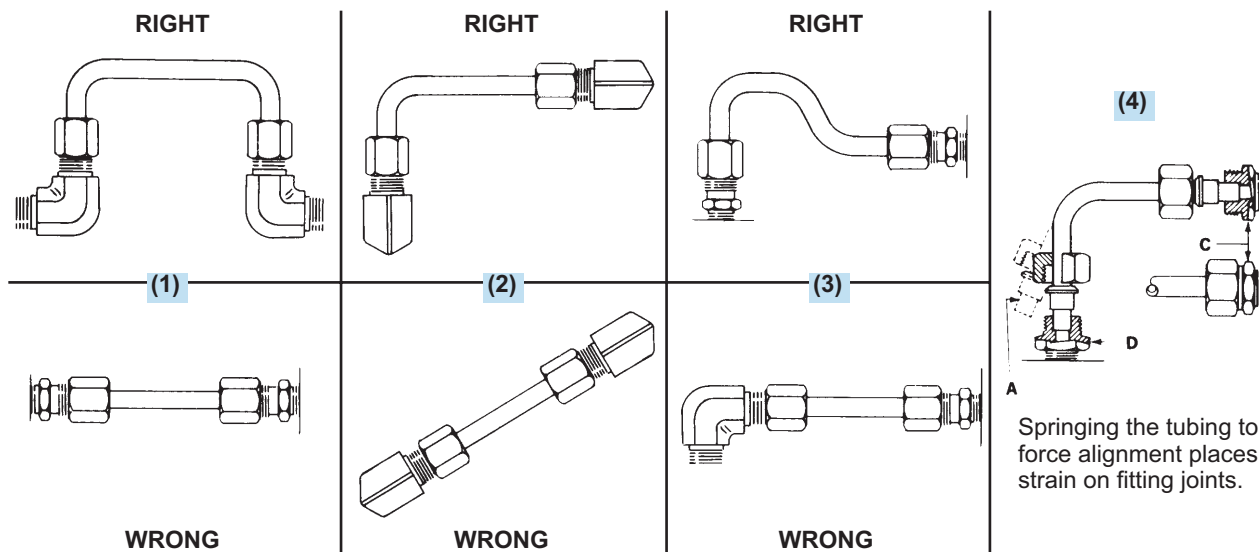

Nearly all industrial equipment now in service makes some use of fluid lines. From an economic point of view, the best fluid lines system is that which is easiest to maintain at the lowest original cost. The use of tubing and tube fittings on lines up to 2" diameter is usually more economical than the use of pipe and pipe fittings in modern installations. A few of the more important reasons follow:

1. Size for size, tubing is lighter weight, easier to handle and can be bent more easily than iron pipe.
2. Ductile hydraulic tubing reduces the number of connections required, thus reducing material and labor costs. Bent tubing also reduces pressure drop and turbulence in the system.
3. Fewer joints means lower costs and fewer points of potential leakage.
4. The use of tube fittings makes every joint a union, permitting easier, faster maintenance and repair work.
5. Modern flared and flareless tube fittings eliminate the need for threading, soldering, or welding.

### TUBE BENDING

Tubing should be bent wherever possible to reduce the number of fittings.

Copper tubing can be bent easily with a hand bender. Steel tubing can be bent in sizes 1/8" to 5/8" O.D. by using a hand bender designed for steel tubing. For production quantities, or for sizes larger than 5/8" O.D., a power bender is generally used.

Tubing should be bent accurately. Tubing manufacturers will advise the correct radii for various types and wall thicknesses of tubing. Kinks, flattened bends, wrinkles and tube breakage or loss should be avoided by the use of proper tube bending equipment.

### PRECAUTIONS

Avoid straight line connections wherever possible, especially in short runs.

Design piping systems symmetrically. They are easier to install and present a neat appearance.

Care should be taken to eliminate stress from tubing lines. Long tubing runs should be supported by brackets or clips. All parts installed on tubing lines such as heavy fittings, valves, etc., should be bolted down to eliminate tubing fatigue.

Before installing tubing, inspect the tube to see that it conforms to the required specifications, is of the correct diameter and wall thickness and is not out of round.

Cut tube ends reasonably square and lightly deburr inside and outside edge. Chamfer on outside edge will destroy bearing of tube end on the fittings seat.

To avoid difficulty in assembly and disconnecting, a sufficient straight length of tube must be allowed from the end of the tube to the start of the bend. Allow twice the length of the nut as a minimum.

**Tubes should be formed to assemble with true alignment to the center line of the fittings, without distortion or tension.** Tubing which has to be sprung from position, "A", (see Fig. 4), to be inserted into the fitting has not been properly fabricated, and when so installed and connected, places the tubing under stress.

When assembling the tubing, insert the longer leg to the fitting as at "C" (Fig. 4). With the nut free, the short leg of the tubing can be easily moved and brought to proper position with and inserted into the seat in fitting "D". The nuts can then be tightened as required.



Refer to safety information regarding proper selection of tubing and tube fittings on page 1.

These tables alphabetically list commonly used materials of various chemical composition. After each agent listing you will find the basic tubing and fitting materials rated according to their chemical resistance to each individual agent. The chart is intended to be used as a guide only. Many factors (concentration, temperature, intermittent or continuous exposure, etc.) have a bearing upon the suitability of any tubing or connector for any specific application, and these factors must be considered by you as you review the chemical compatibility chart.

Where unusual conditions exist or where questions arise, consult Dana Corporation for expert assistance on your tubing application requirements.

Fluid	Nylon 11 TP160, NT100	Nylon 6/6 PT200	PVC PT230	Polyethylene PT240 (LDPE)	Brass	Steel	316 Stainless
Acetaldehyde	G	F	X	X	X	X	G
Acetic Acid (Concentrated)	X	X	X	X	X	X	G
Acetic Acid (Dilute)	F	X	F	G	X	X	G
Acetic Anhydride	X	X	X	X	X	F	F
Acetone	G	F	X	G	G	G	G
Acrylonitrile	G	—	G	—	—	G	G
Air	G	G	G	G	G	G	G
Alcohols							
Amyl Alcohol	G	G	X	G	G	F	F
Butyl Alcohol, Butanol	G	G	X	G	G	G	G
Ethyl Alcohol, Ethanol	G	G	F	G	G	F	G
Isopropyl Alcohol, Isopropanol	G	G	G	G	G	G	G
Methyl Alcohol, Methanol	G	G	X	G	G	F	G
Aluminum Chloride	X	X	G	G	X	X	F
Aluminum Fluoride	X	X	G	G	X	X	X
Aluminum Hydroxide	G	G	G	G	X	F	G
Aluminum Nitrate	G	F	G	G	X	X	G
Aluminum Sulfate	G	F	G	G	X	X	G
Alums	F	G	G	G	X	X	F
Ammonia, Anhydrous	Use approved anhydrous ammonia hose				X	F	G
Ammonia Solution (10%)	G	X	G	G	X	G	G
Ammonium Chloride	X	X	G	G	X	G	F
Ammonium Hydroxide	G	X	X	G	X	F	G
Ammonium Nitrate	G	G	G	G	—	—	G
Ammonium Phosphate	G	G	F	G	X	X	G
Ammonium Sulfate	G	G	G	G	X	X	F
Amyl Acetate	G	G	X	X	G	F	G
Amyl Alcohol	G	G	X	G	G	F	F
Aniline	X	X	X	X	X	G	G
Aniline Dyes	X	X	X	X	X	X	F
Animal Oils and Fats	G	—	G	X	G	G	G
Anti-Freeze (Glycol Base)	G	—	G	F	G	G	G
Aqua Regia	X	X	X	X	—	X	X
Aromatic Hydrocarbons	G	G	X	G	G	G	G
Asphalt Emulsion	G	—	X	—	G	G	G
Barium Chloride	G	—	G	G	X	F	G
Barium Hydroxide	G	G	G	G	X	G	G
Barium Sulfate	G	G	G	G	G	G	G
Barium Sulfide	X	—	G	G	X	X	G
Beet Sugar Liquors	G	G	G	G	X	G	G
Benzaldehyde	G	G	X	X	F	F	G
Benzene, Benzol	G	G	X	X	G	G	G
Benzoic Acid	X	X	X	G	F	X	F
Black Sulfate Liquor	X	X	X	G	X	G	G
Bleach Solution	X	X	F	G	X	X	G
Borax Solution	G	—	G	G	G	G	G
Boric Acid	G	G	G	G	X	X	G
Brake Fluid (Glycol Ether Base)	G	—	X	X	G	G	G
Brine	G	—	G	G	—	X	F
Bromine	X	X	X	X	X	X	X

NOTE: All data given herein is believed to be accurate and reliable but presented without guarantee, warranty, or responsibility of any kind, express or implied, on our part. Chemical resistance will vary with the wide diversity of possible mixtures and service conditions. It is not therefore possible to give any guarantee whatsoever in individual cases. CODES: G=Good Resistance F=Fair Resistance X=Incompatible —=No data available

+ Call Technical Support for specific application

# Chemical Compatibility Chart

Application



Refer to safety information regarding proper selection of tubing and tube fittings on page 1.

Fluid	Nylon 11 TP160, NT100	Nylon 6/6 PT230	PVC PT200	Polyethylene PT240 (LDPE)	Brass	Steel	316 Stainless
Butane	Use H336 or H243 Hose Only						
Butyl Acetate	G	—	X	X	G	G	G
Butyl Alcohol, Butanol	G	G	X	G	G	G	G
Calcium Bisulfite	G	X	G	G	X	X	X
Calcium Chloride	G	X	G	G	X	F	F
Calcium Hydroxide	G	G	G	G	F	G	G
Calcium Hypochlorite	X	X	G	G	F	X	F
Cane Sugar Liquors	G	—	G	G	F	G	G
Carbon Dioxide (Dry)	G	G	G	G	G	G	G
Carbon Dioxide (Wet)	G	G	G	G	F	G	G
Carbon Disulfide (Bisulfide)	X	X	X	X	G	G	G
Carbon Monoxide (Hot)	X	X	X	X	X	F	G
Carbon Tetrachloride	G	G	X	X	G	G	G
Carbonic Acid	G	—	G	G	X	X	F
Castor Oil	G	—	G	X	G	G	G
Cellosolve Acetate	G	—	X	—	X	X	G
Chlorinated Solvents	F	G	X	X	G	G	F
Chloroacetic Acid	X	X	X	X	X	X	F
Chlorobenzene	X	X	X	X	F	F	G
Chlorine Gas (Dry)	X	X	X	X	F	F	G
Chlorine Gas (Wet)	X	X	X	X	X	X	X
Chloroform	F	G	X	X	G	G	G
Chlorosulfonic Acid	X	X	X	X	X	F	X
Chromic Acid (under 25%)	X	X	F	F	X	X	G
Chromic Acid (over 25%)	X	X	X	X	X	X	F
Citric Acid	X	F	G	G	X	X	G
Coke Oven Gas	G	—	X	G	F	G	G
Copper Chloride	X	X	G	G	X	X	G
Copper Cyanide	G	G	G	G	X	X	G
Copper Sulfate	G	G	G	G	X	X	G
Corn Syrup (Non-food)	G	—	G	G	—	G	G
Cottonseed Oil	G	—	F	G	G	G	G
Creosote	X	X	X	X	F	—	G
Cresol	X	X	X	X	—	G	G
Cyclohexanol	G	G	X	F	G	F	G
Dextrose (Food Grade)	X	X	X	G	—	—	G
Dichlorobenzene	G	—	X	X	—	—	G
Diesel Fuel	G	—	X	X	G	G	G
Diethanolamine	G	—	X	—	X	G	G
Diethylenetriamine	X	X	X	G	—	—	—
Dowtherm A	X	X	X	X	X	F	G
Enamel (Solvent Base)	G	—	X	G	G	—	G
Ethanolamine	G	—	X	G	X	G	G
Ethers (Ethyl Ether)	G	—	X	X	G	G	G
Ethyl Alcohol	G	G	F	G	F	G	G
Ethyl Acetate	G	G	X	G	G	G	G
Ethyl Acrylate	X	—	X	—	—	G	G
Ethyl Methacrylate	X	—	X	—	—	G	G
Ethylamine	X	X	X	G	G	—	G
Ethyl Cellulose	F	—	X	G	F	G	F
Ethyl Chloride	G	—	X	X	F	F	G
Ethylenediamine	X	X	X	G	G	G	G
Ethylene Dibromide	F	—	X	—	—	—	—
Ethylene Dichloride	F	—	X	X	G	X	X
Ethylene Glycol	G	G	G	G	F	G	G
Ethylene Oxide	G	—	X	X	X	F	F

NOTE: All data given herein is believed to be accurate and reliable but presented without guarantee, warranty, or responsibility of any kind, express or implied, on our part. Chemical resistance will vary with the wide diversity of possible mixtures and service conditions. It is not therefore possible to give any guarantee whatsoever in individual cases. CODES: G=Good Resistance F=Fair Resistance X=Incompatible —=No data available

+ Call Technical Support for specific application

APPLICATION



 Refer to safety information regarding proper selection of tubing and tube fittings on page 1.

Fluid	Nylon 11 TP160, NT100	Nylon 6/6 PT230	PVC PT200	Polyethylene PT240 (LDPE)	Brass	Steel	316 Stainless
Fatty Acids	G	G	G	G	F	F	G
Ferric Chloride 5%	G	G	G	G	X	X	X
Ferric Sulfate	G	G	G	G	X	X	F
Fertilizer Salts Solution	F	—	G	G	—	—	G
Formaldehyde	G	G	X	G	F	X	G
Formic Acid	X	X	X	G	F	X	G
Freon 12	Use approved Freon 12 hose				G	G	G
Freon 134a	Use approved Freon 134a hose				—	G	G
Fuel Oil	G	—	F	X	F	G	G
Furfural	X	X	X	X	F	G	G
Gasoline (Refined)	G	G	X	X	G	G	G
Gasoline (Unleaded)	G	G	X	X	G	G	G
Gasoline (10% Ethanol)	G	G	X	X	G	G	G
Gasoline (10% Methanol)	G	G	X	X	G	G	G
Glucose (non-food)	G	G	G	G	G	G	G
Glycerine, Glycerol (Non-food)	G	G	G	G	G	G	G
Greases	G	G	G	G	G	G	G
Green Sulfate Liquor	X	X	G	G	X	X	G
Heptane	G	G	X	X	G	G	G
Hexane	G	G	X	X	G	G	G
Houghto Safe 273 to 640	G	—	F	G	G	G	G
Houghto Safe 5046, 5047F	G	—	G	G	G	G	G
Houghto Safe 1000 Series	G	—	X	X	G	G	G
Hydraulic Oils							
Straight Petroleum Base	G	G	G	G	G	G	G
Water Petroleum Emulsion	G	—	—	F	G	G	G
Water Glycol	G	G	X	—	G	G	G
Straight Phosphate Ester	G	G	X	X	G	G	G
Phos. Ester/Petroleum Blend	G	G	X	X	G	G	G
Polyol Ester	G	—	—	—	G	G	G
Hydrobromic Acid (under 48%)	X	X	G	G	X	X	X
Hydrochloric Acid	X	X	G	G	X	X	X
Hydrocyanic Acid	X	X	G	G	X	F	G
Hydrofluoric Acid (under 50%)	X	X	F	F	X	X	G
Hydrofluoric Acid (over 50%)	X	X	X	X	X	X	G
Hydrofluosilicic Acid	X	X	G	G	X	X	X
Hydrogen	Use approved hydrogen hose or metal tubing				—	—	G
Hydrogen Peroxide	X	X	—	G	X	X	G
Hydrogen Sulfide	X	X	G	G	F	F	F
Hydrolube	G	—	G	G	G	G	G
Iodine	X	X	X	X	X	X	X
Isocyanates	X	X	X	X	—	—	—
Isopropyl Alcohol, Isopropanol	G	G	G	G	G	G	G
Isopropylamine	X	—	X	—	G	—	G
Iso-Octane	G	G	X	X	G	G	G
Jet Fuel (Transfer Only)	G	G	X	X	G	F	G
Kerosene	G	G	X	X	G	G	G
Lacquer	G	G	X	F	G	X	G
Lacquer Solvents	G	G	X	F	G	X	G
Lactic Acid	G	G	G	G	F	F	G
Lime Sulfur	G	F	G	G	X	—	G
Lindol	G	G	—	—	F	G	G
Linseed Oil	G	G	G	G	F	G	G
Lubricating Oils	G	G	G	G	G	G	G
Lye	G	F	G	G	F	X	G
Magnesium Chloride	G	G	G	G	F	F	G

NOTE: All data given herein is believed to be accurate and reliable but presented without guarantee, warranty, or responsibility of any kind, express or implied, on our part. Chemical resistance will vary with the wide diversity of possible mixtures and service conditions. It is not therefore possible to give any guarantee whatsoever in individual cases. CODES: G=Good Resistance F=Fair Resistance X=Incompatible —=No data available

+ Call Technical Support for specific application



# Chemical Compatibility Chart

Application



Refer to safety information regarding proper selection of tubing and tube fittings on page 1.

Fluid	Nylon 11 TP160, NT100	Nylon 6/6 PT230	PVC PT200	Polyethylene PT240 (LDPE)	Brass	Steel	316 Stainless
Magnesium Hydroxide	G	G	G	G	G	G	G
Magnesium Sulfate	G	G	G	G	F	G	G
Mercuric Chloride	X	X	F	G	X	X	X
Mercury	G	G	F	G	X	G	G
Methyl Alcohol, Methanol	G	G	X	G	F	G	G
Methyl Acrylate	X	X	X	—	G	G	G
Methyl Bromide	G	F	X	X	G	G	G
Methyl Chloride	G	G	X	X	G	G	G
Methylene Chloride	F	F	X	X	G	G	G
Methyl t-Butyl Ether (MTBE)	G	G	X	—	—	G	G
Methyl Ethyl Ketone	G	G	X	G	G	G	G
Methyl Isobutyl Ketone	G	G	X	G	G	G	G
Methyl Isopropyl Ketone	G	G	X	G	G	G	G
Methyl Methacrylate	X	—	X	—	—	G	G
Mineral Oil	G	G	F	X	G	G	G
Mineral Spirits	G	G	X	G	G	G	G
Naphtha	G	G	X	G	F	G	G
Naphthalene	G	G	X	X	F	G	G
Nickel Acetate	G	G	G	G	G	G	G
Nickel Chloride	G	G	G	G	X	X	F
Nickel Sulfate	G	G	G	G	X	X	G
Nitric Acid (under 35%)	X	X	G	F	X	X	G
Nitric Acid (35% to 60%)	X	X	F	X	X	X	G
Nitric Acid (over 60%)	X	X	X	X	X	X	G
Nitrobenzene	X	—	X	X	F	G	G
Nitrogen Gas	G	G	G	G	G	G	G
Nitrous Oxide	F	F	X	X	G	G	G
Oleic Acid	G	G	F	G	F	F	G
Oleum (Fuming Sulfuric Acid)	X	X	X	X	X	F	G
Oxalic Acid	X	X	G	G	F	X	G
Oxygen	G	G	G	G	G	G	G
(non-breathing, non-welding) +							
Ozone (300 ppm)	X	X	X	X	—	F	G
Paint (Solvent Base)	G	G	X	F	G	G	G
Palmitic Acid	G	G	F	G	X	F	F
Paper Mill Liquors	X	X	X	X	—	—	—
Pentane	G	—	X	X	G	G	G
Perchloroethylene	F	G	X	X	F	G	G
Petroleum Ether	G	G	X	X	G	G	G
Petroleum Oils	G	G	G	G	G	G	G
Phenol	X	X	X	X	F	X	F
Phosphoric Acid (to 85%)	X	X	G	G	X	X	F
Picric Acid (Molten)	X	X	X	X	X	X	F
Picric Acid (Solution)	X	X	X	X	X	X	F
Potassium Chloride	G	G	G	G	F	X	G
Potassium Cyanide	G	G	G	G	X	G	G
Potassium Dichromate	F	—	G	G	X	G	G
Potassium Hydroxide	G	F	G	G	F	X	G
Potassium Permanganate	X	X	G	G	—	—	—
Potassium Sulfate	G	G	G	G	F	F	G
Propane Liquid							
Propylene Glycol	G	—	F	G	F	G	G
Pyridine	X	X	X	G	F	G	G
Sea Water	G	G	G	G	G	F	G
Silver Nitrate	G	G	G	G	X	X	F
Skydrol	G	G	X	X	G	G	G

NOTE: All data given herein is believed to be accurate and reliable but presented without guarantee, warranty, or responsibility of any kind, express or implied, on our part. Chemical resistance will vary with the wide diversity of possible mixtures and service conditions. It is not therefore possible to give any guarantee whatsoever in individual cases. CODES: G=Good Resistance F=Fair Resistance X=Incompatible — =No data available

+ Call Technical Support for specific application

APPLICATION

 Refer to safety information regarding proper selection of tubing and tube fittings on page 1.

Fluid	Nylon 11 TP160, NT100	Nylon 6/6 PT230	PVC PT200	Polyethylene PT240 (LDPE)	Brass	Steel	316 Stainless
Soap Solution	G	G	G	X	G	G	G
Sodium Bicarbonate	G	G	G	G	F	F	G
Sodium Bisulfate	G	G	G	G	F	F	F
Sodium Bisulfite	G	G	G	G	F	X	G
Sodium Borate	G	G	G	G	G	G	G
Sodium Carbonate	G	G	G	G	X	G	G
Sodium Chloride	G	G	G	G	X	F	G
Sodium Cyanide	G	G	G	G	X	F	G
Sodium Hydroxide	G	F	G	G	F	X	G
Sodium Hypochlorite	X	X	G	G	X	X	F
Sodium Nitrate	G	G	G	G	F	G	G
Sodium Perborate	G	F	G	G	F	F	G
Sodium Peroxide	X	X	X	X	X	F	G
Sodium Phosphates	G	G	G	G	F	F	F
Sodium Silicate	G	G	G	G	F	F	G
Sodium Sulfate	G	G	G	G	F	F	G
Sodium Sulfide	G	G	G	G	X	X	G
Sodium Thiosulfate	G	G	G	G	X	X	G
Soybean Oil	G	—	F	G	G	G	G
Stannic Chloride	F	X	G	G	X	X	X
Steam 450° F	X	X	X	X	F	F	G
Stearic Acid	G	G	F	G	X	X	G
Stoddard Solvent	G	G	X	X	G	G	G
Styrene	G	G	X	X	G	G	G
Sulfur 70o F	G	G	F	G	X	X	G
Sulfur 200o F	X	X	X	X	X	X	G
Sulfur Chloride	X	X	X	G	X	X	X
Sulfur Dioxide	X	X	X	X	X	—	G
Sulfuric Acid (under 50%)	X	X	G	G	X	X	X
Sulfuric Acid (51% to 70%)	X	X	G	X	X	X	X
Sulfuric Acid (71% to 95%)	X	X	X	X	X	X	X
Sulfuric Acid (96% to 98%)	X	X	X	X	X	X	X
Tannic Acid	X	X	G	G	F	X	G
Tar	G	G	X	X	F	F	G
Tartaric Acid	G	G	G	G	F	X	F
Tetrachloroethane	F	—	X	F	—	—	G
Tetrahydrofuran (THF)	G	—	X	X	—	—	G
Toluene	G	G	X	G	G	G	G
Transmission Oil (Petrol. Base)	G	G	G	G	G	G	G
Trichloroethane	F	G	X	G	G	G	G
Trichloroethylene	F	G	X	G	G	G	G
Tung Oil	G	—	—	—	F	G	G
Turpentine	G	G	X	G	F	G	G
Urea (Water Solution)	G	G	G	G	—	G	G
Uric Acid	G	G	G	G	—	—	F
Varnish	G	G	X	G	G	G	G
Vegetable Oil (Non-food)	G	G	F	G	G	G	G
Vinegar	G	X	G	G	X	F	G
Vinyl Acetate	G	—	X	—	F	G	G
Water (non-potable)	G	G	G	G	F	F	G
Water-Glycol Mixture	G	G	X	—	G	G	G
Water-Petroleum Mixture	G	G	—	F	G	G	G
Xylene	G	G	X	G	G	G	G
Zinc Chloride	X	X	G	G	X	X	X
Zinc Sulfate	G	G	G	G	X	X	G



NOTE: All data given herein is believed to be accurate and reliable but presented without guarantee, warranty, or responsibility of any kind, express or implied, on our part. Chemical resistance will vary with the wide diversity of possible mixtures and service conditions. It is not therefore possible to give any guarantee whatsoever in individual cases. CODES: G=Good Resistance F=Fair Resistance X=Incompatible —=No data available

+ Call Technical Support for specific application

# Plastic Tubing

## Tubing

Example of complete part numbers: NT10006RD-100 (Catalog Number, Color, Coil Length)



<b>NT100 "Nylon 11"</b> <b>SAE J844 Type A &amp; B</b> <b>DOT FMVSS 571.106</b>	Catalog Number	Tube O.D. (in)	Tube Wall (in)	Max. Work. Pres. PSI 75°F	Min. Burst Pres. PSI 75°F	Min. Bend Radius 70°F	Lbs. Per 100 Ft.	Coil Length(s) (Ft.)	Fittings
 <p><b>Typical Application:</b> Air brake systems except where temperatures exceed +200°F or where battery acid can drip on tubing.</p> <p><b>Construction:</b> Core, Nylon; Braid, Polyamide Fiber (3/8" and larger sizes only); Jacket, Nylon.</p> <p><b>Temperature Range:</b> -40°F to +200°F (-40°C to +93°C)</p> <p><b>Available Colors:</b> Black (BK), red (RD), blue (BU), brown (BR), green (GN), yellow (YW), orange (OR) and white (WH). Refer to current price list for availability of colors. Example of complete part numbers: NT10006RD-100.</p> <p><b>Contains:</b> Ultra-Violet Stabilizer in all colors.</p> <p><b>NOTE:</b> 1/8", 1/4" and 5/16", are SAE J844 Type A (not reinforced); 3/8", 1/2", 5/8" and 3/4" are SAE J844 Type B (reinforced).</p> <p>* Insert not required. Does not meet DOT standards.</p>	<p>NT10002 *</p> <p>NT10025 *</p> <p>NT10003</p> <p>NT10004</p> <p>NT10005</p> <p>NT10006</p> <p>NT10008</p> <p>NT10010</p> <p>NT10012</p>	<p>1/8 (.125)</p> <p>5/32 (.156)</p> <p>3/16 (.187)</p> <p>1/4 (.250)</p> <p>5/16 (.312)</p> <p>3/8 (.375)</p> <p>1/2 (.500)</p> <p>5/8 (.625)</p> <p>3/4 (.750)</p>	<p>.023</p> <p>.032</p> <p>.035</p> <p>.040</p> <p>.040</p> <p>.062</p> <p>.062</p> <p>.092</p> <p>.092</p>	<p>150</p> <p>150</p> <p>150</p> <p>150</p> <p>150</p> <p>150</p> <p>150</p> <p>150</p>	<p>1000</p> <p>1200</p> <p>1200</p> <p>1200</p> <p>1000</p> <p>1400</p> <p>950</p> <p>900</p> <p>800</p>	<p>.375"</p> <p>.5"</p> <p>.75"</p> <p>1.0"</p> <p>1.25"</p> <p>1.5"</p> <p>2.0"</p> <p>2.5"</p> <p>3.0"</p>	<p>.4</p> <p>.4</p> <p>.6</p> <p>1.2</p> <p>1.8</p> <p>2.9</p> <p>3.8</p> <p>6.8</p> <p>8.4</p>	<p>100,500,1000</p> <p>100,1000</p> <p>1000</p> <p>100,500,1000</p> <p>100,500,1000</p> <p>100,500,1000</p> <p>100,500,1000</p> <p>100,250</p> <p>100,250</p>	<p>WEATHERHEAD 1800 SERIES Q&gt;CAB® FITTINGS (Pg. 84-92).</p> <p>WEATHERHEAD 1400 SERIES AIR BRAKE Fittings. (Pg. 93-98) For 1/8" NT10002 Tubing use SELFALIGN® Fittings (Pg. 53-59). NOTE: SELFALIGN® Fittings are not designed to meet DOT standards.</p>
<p><b>PT200 Polyvinyl Chloride</b></p>  <p><b>Typical Application:</b> Soft, pliable, plasticized PVC Resin Tubing, for practically any low pressure laboratory, industrial, agricultural or domestic application.</p> <p><b>Temperature Range:</b> -5°F to +105°F (-20°C to +41°C)</p> <p><b>Available Colors:</b> Clear (suffix NA)</p> <p><b>NOTE:</b> Not all colors available in all sizes. Refer to price pages for availability.</p>	<p>PT20004</p> <p>PT20044</p> <p>PT20005</p> <p>PT20006</p> <p>PT20008</p> <p>PT20010</p> <p>PT20012</p> <p>PT20016</p>	<p>1/4 (.250)</p> <p>1/4 (.250)</p> <p>5/16 (.312)</p> <p>3/8 (.375)</p> <p>1/2 (.500)</p> <p>5/8 (.625)</p> <p>3/4 (.750)</p> <p>1(1.00)</p>	<p>.062</p> <p>.040</p> <p>.062</p> <p>.062</p> <p>.062</p> <p>.062</p> <p>.094</p> <p>.125</p>	<p>65</p> <p>55</p> <p>55</p> <p>55</p> <p>45</p> <p>30</p> <p>40</p> <p>35</p>	<p>195</p> <p>165</p> <p>165</p> <p>165</p> <p>135</p> <p>90</p> <p>120</p> <p>105</p>	<p>1.0"</p> <p>1.0"</p> <p>1.25"</p> <p>1.5"</p> <p>2.0"</p> <p>2.5"</p> <p>3.0"</p> <p>4.0"</p>	<p>2.0</p> <p>2.0</p> <p>2.6</p> <p>3.3</p> <p>4.6</p> <p>5.9</p> <p>10.3</p> <p>18.5</p>	<p>100</p> <p>100</p> <p>100</p> <p>100</p> <p>100</p> <p>100</p> <p>100</p> <p>100</p>	<p>WEATHERHEAD POLYLINE® (Pg.60-65). SELFALIGN® (Pg. 53-59) with 2030x insert, and COMPRESSION (Pg. 47-52), with 2030x insert. See page 48 for insert. MOLDED COMPRESSION (Pg. 131-137).</p>
<p><b>PT230 Polyamide "Nylon 6/6"</b></p>  <p>Natural off-white compound covered under FDA 121.2502 regulations for food contact.</p> <p><b>Typical Application:</b> Semi-rigid general purpose tubing.</p> <p><b>Temperature Range:</b> -40°F to +180°F (-40°C to +82°C)</p> <p><b>Available Colors:</b> Natural off-white (NA) and black (BK). FDA colors available on request.</p> <p><b>Contains:</b> Ultra-Violet Stabilizer in black tubing.</p>	<p>PT23002</p> <p>PT23003</p> <p>PT23004</p> <p>PT23005</p> <p>PT23006</p> <p>PT23008</p>	<p>1/8 (.125)</p> <p>3/16 (.188)</p> <p>1/4 (.250)</p> <p>5/16 (.312)</p> <p>3/8 (.375)</p> <p>1/2 (.500)</p>	<p>.015</p> <p>.023</p> <p>.030</p> <p>.036</p> <p>.040</p> <p>.062</p>	<p>300</p> <p>300</p> <p>300</p> <p>300</p> <p>300</p> <p>300</p>	<p>1000</p> <p>1000</p> <p>1000</p> <p>1000</p> <p>1000</p> <p>1000</p>	<p>.75"</p> <p>1.25"</p> <p>1.5"</p> <p>2.0"</p> <p>2.25"</p> <p>3.0"</p>	<p>.3</p> <p>.6</p> <p>1.0</p> <p>1.5-1.6</p> <p>2.1</p> <p>4.2-4.3</p>	<p>100,1000</p> <p>100,1000</p> <p>100,1000</p> <p>100,1000</p> <p>100,1000</p> <p>100, 500</p>	<p>WEATHERHEAD SELFALIGN® (Pg. 53-59). PUSH &gt; CONNECT (Pg. 66-71), PUSH &gt; CONNECT Flow Controls (Pg. 66, 76 &amp; 77), PUSH &gt; CONNECT PLUS (Pg. 78-79), and POLYLINE® w/brass sleeves (Pg. 60-65).</p>

**NOTE:** SELFALIGN® Fittings are not designed to meet DOT standards. For plastic tube cutter, see page 227.

TUBING



Example of complete part numbers: NT10006RD-100 (Catalog Number, Color, Coil Length)

<b>PT240 Polyethylene</b>  	Catalog Number	Tube O.D. (in)	Tube Wall (in)	Max. Work. Pres. PSI 70°F	Min. Burst Pres. PSI 70°F	Min. Bend Radius 70°F	Lbs. Per 100 Ft.	Coil Length(s) (Ft.)	Fittings
<p>Natural off-white compound covered under FDA 121.2502 regulations for food contact. <b>Typical Application:</b> Economical, flexible, low density Polyethylene has a wide range of uses in industrial and agricultural applications.</p> <p><b>Temperature Range:</b> -40°F to +135°F (-40°C to +57°C)</p> <p><b>Available Colors:</b> Natural off-white (NA), black (BK), yellow (YW), orange (OR), blue (BU), red (RD), green. FDA colors available on request. Refer to current price list for availability of colors.</p> <p><b>Contains:</b> Ultra-Violet Stabilizer in black tubing.</p>	<p><a href="#">PT24004</a> <a href="#">PT24044</a> <a href="#">PT24005</a> <a href="#">PT24006</a> <a href="#">PT24008</a> <a href="#">PT24010</a> <a href="#">PT24012</a> <a href="#">PT24016</a></p>	<p>1/4 (.250) 1/4 (.250) 5/16 (.312) 3/8 (.375) 1/2 (.500) 5/8 (.625) 3/4 (.750) 1 (1.000)</p>	<p>.062 .040 .062 .062 .062 .062 .094 .125</p>	<p>200 133 135 135 100 80 70 100</p>	<p>600 400 480 400 300 240 210 300</p>	<p>.75" .62" 1.0" 1.5" 2.0" 2.5" 3.0" 5.0"</p>	<p>1.5 1.0 1.9 2.4 3.4 4.4 7.6 13.4</p>	<p>100,1000 100,1000 100,1000 100,1000 100, 500 100 100 100</p>	<p>WEATHERHEAD MINIBARB® (Pg. 80-83), POLYLINE® (Pg. 60-65), SELFALIGN® (Pg. 53-59) with 2030 insert (Pg. 55), and PUSH &gt; CONNECT Flow Controls (Pg. 66, 76 &amp; 77), PUSH &gt; CONNECT (Pg. 66-71), PUSH &gt; CONNECT PLUS (Pg. 78-79), MOLDED COMPRESSION (Pg. 131-137).</p>
<b>TP160 Polyamide "Nylon 11"</b>  	Catalog Number	Tube O.D. (in)	Tube Wall (in)	Max. Work. Pres. PSI 70°F	Min. Burst Pres. PSI 70°F	Min. Bend Radius 70°F	Lbs. Per 100 Ft.	Coil Length(s) (Ft.)	Fittings
<p><b>Typical Application:</b> Flexible nylon tubing. Used for instrumentation; lubrication and air lines; gas, chemical and oil processing; low pressure hydraulics.</p> <p><b>Temperature Range:</b> -40°F to +200°F (-40°C to +93°C)</p> <p><b>Available Colors:</b> Black (BK) or natural (NA).</p> <p><b>Contains:</b> Ultra-Violet Stabilizer in black tubing.</p>	<p><a href="#">TP16002</a> <a href="#">TP16025</a> <a href="#">TP16004</a> <a href="#">TP16005</a> <a href="#">TP16006</a> <a href="#">TP16008</a></p>	<p>1/8 (.125) 5/32 (.156) 1/4 (.250) 5/16 (.312) 3/8 (.375) 1/2 (.500)</p>	<p>.023 .029 .040 .040 .062 .062</p>	<p>250 250 250 250 250 250</p>	<p>1000 1000 1000 1000 1000 1000</p>	<p>5/8" 1" 1 1/4" 2" 3.0" 4.5"</p>	<p>.30 .75 1.2 2.0 2.7 3.8</p>	<p>100,1000 100,1000 100,1000 100,1000 100,1000 100,500</p>	<p>WEATHERHEAD POLYLINE® with Brass Sleeves (Pg. 60-65), SELFALIGN® (Pg. 53-59), PUSH &gt; CONNECT Flow Controls (Pg. 66, 76 &amp; 77), PUSH &gt; CONNECT (Pg. 66-71), COMPRESSION (Pg. 47-52), PUSH &gt; CONNECT PLUS (Pg. 78-79), MOLDED COMPRESSION (Pg. 131-137).</p>
<b>MTP160 Polyamide "Nylon 11" Metric Tubing</b>  	Catalog Number	Tube O.D. (mm)	Tube Wall (mm)	Max. Work. Pres. PSI 75°F	Min. Burst Pres. PSI 75°F	Min. Bend Radius 75°F	Lbs. Per 100 Ft.	Coil Length(s) (Ft.)	Fittings
<p><b>Typical Application:</b> Flexible nylon tubing. Used for instrumentation; lubrication and air lines; gas, chemical and oil processing; low pressure hydraulics.</p> <p><b>Temperature Range:</b> -40°F to +200°F (-40°C to +93°C)</p> <p><b>Available Colors:</b> Natural (NA).</p> <p><b>Contains:</b> Ultra-Violet Stabilizer</p>	<p><a href="#">MTP16004</a> <a href="#">MTP16005</a> <a href="#">MTP16006</a> <a href="#">MTP16008</a> <a href="#">MTP16010</a> <a href="#">MTP16012</a></p>	<p>4 5 6 8 10 12</p>	<p>.65 1 1 1 1 1</p>	<p>250 250 250 250 200 112</p>	<p>1000 1000 1000 1000 800 450</p>	<p>3/4 1 1 2-1/4 3 3-1/2</p>	<p>0.6 0.9 1.1 1.5 1.9 2.3</p>	<p>100 100 100 100 100 100</p>	<p>WEATHERHEAD METRIC PUSH &gt; CONNECT (Pg. 66, 72-75).</p>

For plastic tube cutter, see page 227.

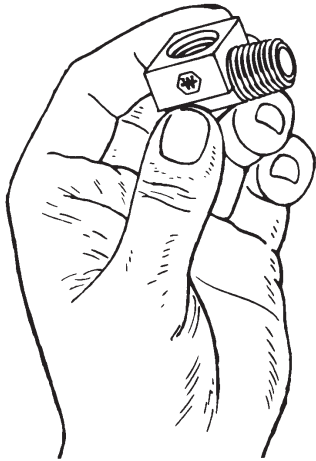

Weatherhead brass tube fittings are made from high quality UNS CA-360 brass bar. Weatherhead brass fittings are precision machined to meet SAE standards and specifications. Large, uniform wrench pad areas have standard dimensions for easy assembly and disassembly using standard open-end wrenches. On fittings where pipe threads are used, the fittings are standardized on Dryseal American National Standard Taper. Weatherhead offers the only complete line of brass fittings with these outstanding advantages.

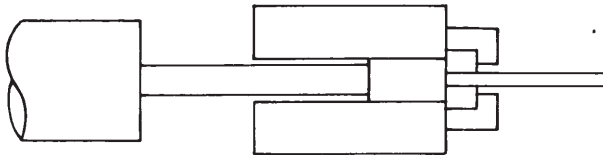

### Hot Extrusion

A cast billet is heated and extruded through a die containing the desired configuration. This process recrystallizes the weaker cast structure into the stronger pressed structure of the shaped extrusion.



### Cold Draw

The hot extruded shape is pulled through a die with the same configuration but less cross sectional area. This further recrystallizes and refines the structure while increasing the strength and elongation. In addition, the dimensions are brought to close tolerances.

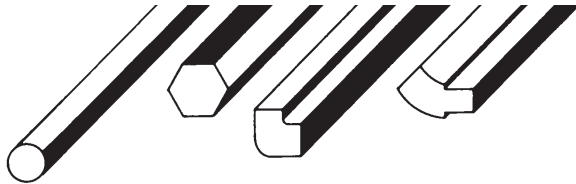

### Shapes

The dies through which the billets are forced may be one of hundreds of shapes. Four of the most common shapes, used in the manufacture of Weatherhead fittings, are illustrated.



### Saw and Machine

The cold bar stock is then cut into individual pieces for precision machining. After the part is machined, it is ready for the market as a strong, tough, high quality fitting. Only by using this process is it possible to get the big all-flat sides on elbows and tees, instead of the usual small wrench pads, or lack of flats altogether.

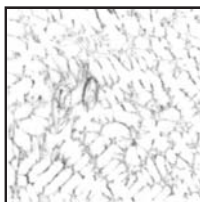

As Cast – 50x

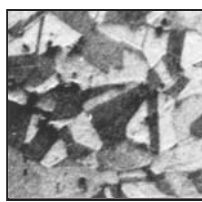

Hot Extruded – 200x

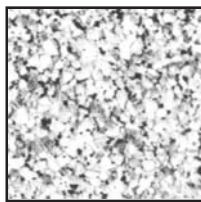

Cold Drawn – 200x

### Microstructure

The photomicrographs illustrate the change in microstructure from the low strength low ductility dendritic structure of the cast billet, to the recrystallized structure of the hot extrusion, to the refined structure of the high strength high ductility cold drawn rod.

 Refer to safety information regarding proper selection of tubing and tube fittings on page 1.

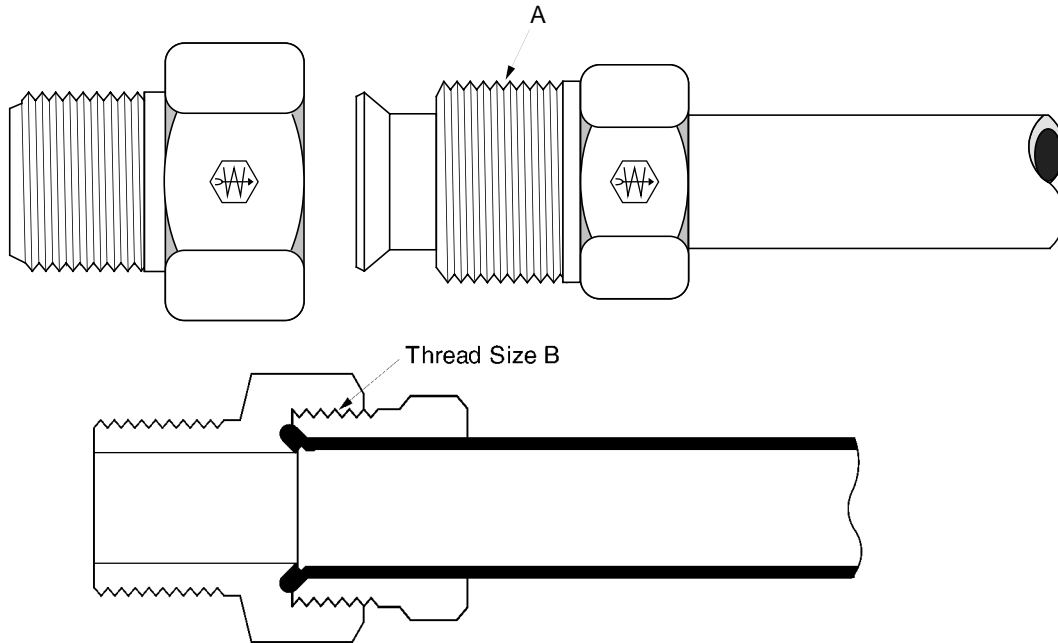

Tube O.D.	1/8	3/16	1/4	5/16	3/8	7/16	1/2	5/8	3/4	7/8	1
Thread Size-B	5/16-28	3/8-24	7/16-24	1/2-20	5/8-18	11/16-18	3/4-18	7/8-18	1-1/16-16	1-3/16-16	1-5/16-16

• **Typical Application**

Hydraulic brake, power steering, fuel lines and transmission cooler lines, LP and natural gas (special order).

• **Pressure**

Working pressure up to 2000 psi depending on tube size. Will withstand burst pressure of standard tubing - up to 5000 psi with Bundy-weld (double flared) and 3500 psi with copper tubing, depending on size.

• **Vibration**

Excellent resistance.

• **Temperature Range**

-65°F to +250°F (-53°C to +121°C) range at maximum operating pressures.

• **Material**

CA360 Brass.

• **Used With**

Copper, brass, aluminum and steel hydraulic tubing that can be flared. See page 28-32 for material compatibility.

• **Advantages**

Very low cost and reusable. Seats and threads are internal and protected. Compact, excellent vibration life. Short nut affords very close tube bends. Steel or brass tube nut.

• **Conformance**

Listed by Underwriter's Laboratories (available on special order) for fuel equipment, refrigeration and gas. Meets specifications and standards of ASA, ASME, SAE and MS (Military Standards).

• **How to Order**

Order individually by catalog number.

• **NOTE:**

Refer to current price list for availability of cataloged items. Configurations and dimensions subject to change without notice. Additional information can be found in SAE J512.

• **Assembly Instructions**

1. Cut tubing to desired length. Make sure all burrs are removed and the ends are cut square.
2. Slide nut on tube. Threaded end "A" of nut must face out.
3. Flare end of tube with a 45° flaring tool. See page 26 for flare data.
  - a. Measure flare diameter.
  - b. Examine flare for excessive thin out.
  - c. On thin wall, welded or brazed tubing, use double flare to prevent pinch-off and cracked flares.
4. Lubricate threads and assemble to fitting body. Nut should be turned hand tight.
5. Tighten assembly with a wrench until a solid feeling is encountered. From that point, apply a one-sixth turn.

**NOTE:** Do not over-torque as it may damage the fittings or split the tubing at the flare.

**Label Set:** **W-8022** (adhesive)  
**CL-490** (non-adhesive)

# Inverted Flare

**Brass  
Fittings**

**Tube Nut  
(Steel)  
(Ref. SAE No. 040110)**

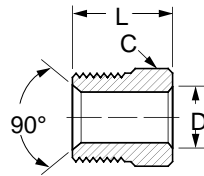

\*3/8" Tube to 11/16-18 Male Thread

Tube O.D.	Catalog Number	Hex C	D	L
1/8	105x2	5/16	.132	.52
3/16	105x3	3/8	.196	.56
1/4	105x4	7/16	.259	.56
5/16	105x5	1/2	.321	.62
3/8	105x6	5/8	.384	.66
3/8	105x6x7*	11/16	.387	.66
7/16	105x7	11/16	.444	.68
1/2	105x8	3/4	.508	.74
5/8	105x10	7/8	.632	.80
3/4	105x12	1-1/16	.757	.88
7/8	105x14	1-3/16	.882	1.06
1	105x16	1-3/8	1.008	1.18

**Tube Nut  
(Brass)  
(Ref. SAE No. 040110)**

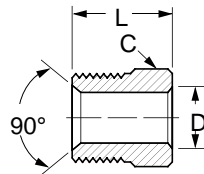

Tube O.D.	Catalog Number	Hex C	D	L
3/16	100x3	3/8	.196	.56
1/4	100x4	7/16	.259	.56
5/16	100x5	1/2	.321	.62
3/8	100x6	5/8	.384	.66
1/2	100x8	3/4	.508	.74

**Plug  
(Steel)  
(Ref. SAE No. 040109)**

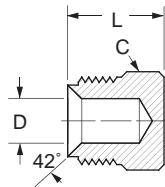
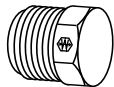

Tube O.D.	Catalog Number	Hex C	D	L
3/16	131x3	3/8	.188	.53
1/4	131x4	7/16	.188	.54
5/16	131x5	1/2	.250	.59
3/8	131x6	5/8	.312	.66

**Tube Nut Long  
(Steel)**

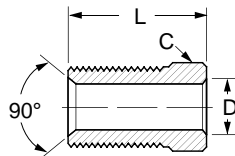
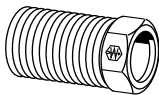

**NOTE:** Required for wheel cylinders with deep port connection.

Tube O.D.	Catalog Number	Hex C	D	L
3/16	7896x3	3/8	.196	.844
1/4	7896x4	7/16	.257	.812

**Union  
(Ref. SAE No. 040101)**

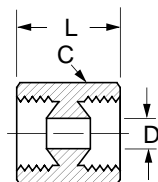
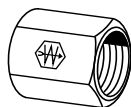

Tube O.D.	Catalog Number	Hex C	D	L
1/8	302x2	13/32	.078	.59
3/16	302x3	15/32	.125	.62
1/4	302x4	17/32	.188	.62
5/16	302x5	19/32	.219	.70
3/8	302x6	3/4	.281	.80
1/2	302x8	29/32	.406	.91
5/8	302x10♦	1-1/16	.531	.97

♦MTO - Made To Order

BRASS



## Adapter SAE 45° Flare to Inv. Flare

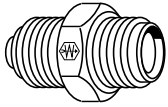

SAE Tube Size	Inverted Male	Catalog Number
1/4	3/16	<b>1518</b>
1/4	1/4	<b>1522</b>
3/8	5/16	<b>1553</b>
3/8	3/8	<b>1563</b>
3/8	7/16	<b>1554</b>

## Male Connector (Ref. SAE No. 040102)

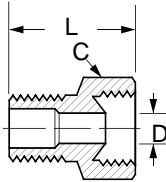
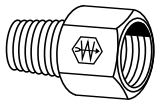

NOTE: Pipe end drill may be reduced or increased from seat dimension 'D'.

Tube O.D.	Male Pipe Thread	Catalog Number	Hex C	D	L
1/8	1/8	<b>202x2</b>	13/32	.078	.62
3/16	1/8	<b>202x3</b>	15/32	.125	.70
1/4	1/8	<b>202x4</b>	17/32	.188	.74
1/4	1/4	<b>202x4x4</b>	9/16	.188	.89
5/16	1/8	<b>202x5</b>	19/32	.219	.79
5/16	1/4	<b>202x5x4</b>	19/32	.220	.98
3/8	1/8	<b>202x6x2</b>	3/4	.281	.89
3/8	1/4	<b>202x6</b>	3/4	.281	1.03
3/8	3/8	<b>202x6x6</b>	3/4	.281	1.01
7/16	1/4	<b>202x7♦</b>	13/16	.344	1.05
1/2	1/4	<b>202x8x4</b>	29/32	.406	1.08
1/2	3/8	<b>202x8</b>	29/32	.406	1.07
1/2	1/2	<b>202x8x8</b>	29/32	.406	1.26
5/8	1/2	<b>202x10</b>	1-1/16	.531	1.32
3/4	1/2	<b>202x12x8♦</b>	1-1/4	.562	1.38
3/4	3/4	<b>202x12</b>	1-1/4	.625	1.39
7/8	3/4	<b>202x14</b>	1-3/8	.750	1.38
1	1	<b>202x16♦</b>	1-1/2	.812	1.62

## Female Connector (Ref. SAE No. 040103)

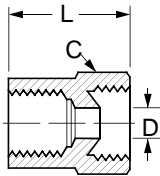
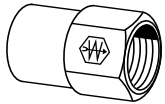

Tube O.D.	Fem. Pipe Thread	Catalog Number	Hex C	D	L
1/8	1/8	<b>252x2♦</b>	1/2	.078	.72
3/16	1/8	<b>252x3</b>	1/2	.125	.75
1/4	1/8	<b>252x4</b>	17/32	.188	.75
5/16	1/8	<b>252x5</b>	19/32	.219	.78
3/8	1/4	<b>252x6♦</b>	3/4	.281	1.03
7/16	1/4	<b>252x7♦</b>	13/16	.343	1.08
1/2	3/8	<b>252x8♦</b>	29/32	.406	1.09
5/8	1/2	<b>252x10♦</b>	1-1/16	.531	1.31
3/4	3/4	<b>252x12♦</b>	1-1/4	.625	1.50

## 45° Male Elbow (Ref. SAE No. 040302)

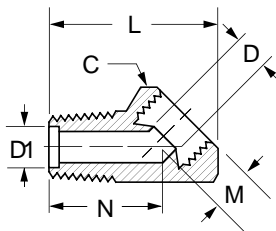
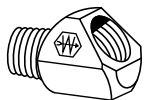

Tube O.D.	Male Pipe Thread	Catalog Number	Hex C	D	D1	L	M	N
1/8	1/8	<b>352x2♦</b>	1/2	.078	.125	.81	.22	.52
3/16	1/8	<b>352x3</b>	17/32	.125	.156	.88	.25	.55
1/4	1/8	<b>352x4</b>	9/16	.188	.188	.94	.27	.58
5/16	1/8	<b>352x5</b>	5/8	.219	.203	1.00	.34	.56
5/16	1/4	<b>352x5x4♦</b>	5/8	.219	.203	1.16	.23	.83
3/8	1/8	<b>352x6x2♦</b>	25/32	.281	.281	1.34	.38	.69
3/8	1/4	<b>352x6</b>	25/32	.281	.219	1.34	.41	.84
1/2	3/8	<b>352x8♦</b>	7/8	.406	.375	1.44	.38	.91
5/8	1/2	<b>352x10♦</b>	1-1/16	.531	.500	1.75	.45	1.09

♦MTO - Made To Order



# Inverted Flare

**Brass  
Fittings**

## Union Elbow (Ref. SAE No. 040201)

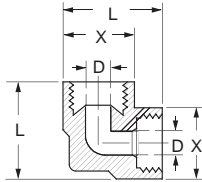
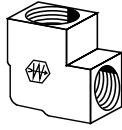

Tube O.D.	Catalog Number	D	L	X
1/4	502x4	.188	.77	.53
5/16	502x5♦	.219	.86	.59
3/8	502x6♦	.281	1.04	.72
1/2	502x8♦	.406	1.25	.88

## Male Elbow (Ref. SAE No. 040202)

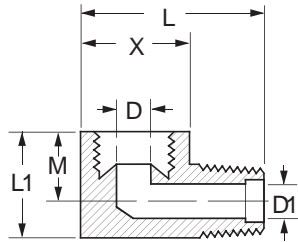
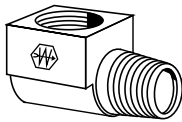

Tube O.D.	Male Pipe Thread	Catalog Number	D	D1	L	L1	M	X
1/8	1/8	402x2	.078	.116	.80	.47	.27	.42
3/16	1/8	402x3	.125	.125	.85	.47	.27	.47
1/4	1/8	402x4	.188	.177	.92	.55	.33	.53
1/4	1/8	431x4*	.188	.062	.91	.53	.33	.53
1/4	1/4	402x4x4	.188	.188	1.09	.58	.28	.56
5/16	1/8	402x5	.219	.219	.98	.67	.47	.59
5/16	1/4	402x5x4	.219	.219	1.16	.75	.45	.59
5/16	3/8	402x5x6♦	.219	.219	1.15	.69	.34	.59
3/8	1/8	402x6x2	.281	.219	1.14	.75	.54	.76
3/8	1/4	402x6	.281	.281	1.32	.82	.53	.76
3/8	3/8	402x6x6	.281	.312	1.32	.84	.50	.75
7/16	1/4	402x7♦	.344	.328	1.42	.88	.59	.84
1/2	1/4	402x8x4♦	.406	.281	1.47	.94	.59	.91
1/2	3/8	402x8	.406	.375	1.48	.94	.59	.91
1/2	1/2	402x8x8	.406	.406	1.67	1.09	.66	.91
5/8	3/8	402x10x6♦	.531	.437	1.62	1.11	.67	1.06
5/8	1/2	402x10♦	.531	.500	1.82	1.11	.67	1.06
3/4	1/2	402x12x8	.625	.531	2.01	1.30	.80	1.25
3/4	3/4	402x12♦	.625	.625	2.01	1.30	.75	1.25
7/8	3/4	402x14	.750	.750	2.12	1.46	.94	1.38
1	1	402x16	.812	.812	2.44	1.70	1.02	1.50

\*.062 dia. restricted hole through pipe end.  
Available on special order with any restricted hole size up to .172 dia.

## Female Elbow (Ref. SAE No. 040203)

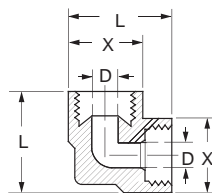
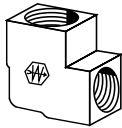

Tube O.D.	Fem. Pipe Thread	Catalog Number	D	L	X
3/16	1/8	452x3♦	.125	.81	.50
1/4	1/8	452x4	.188	.81	.53
5/16	1/8	452x5	.219	.88	.59
3/8	1/4	452x6	.281	1.05	.75
1/2	3/8	452x8♦	.406	1.25	.87
5/8	1/2	452x10♦	.531	1.47	1.06

## Union Tee (Ref. SAE No. 040401)

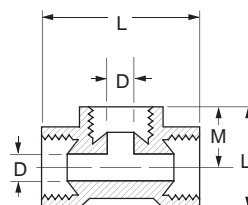
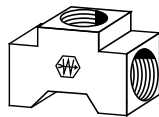

Tube O.D.	Catalog Number	D	L	L1	M
1/8	702x2	.078	.94	.53	.330
3/16	702x3	.125	1.09	.62	.390
1/4	702x4	.188	1.13	.69	.420
5/16	702x5	.219	1.25	.75	.450
3/8	702x6	.281	1.48	.94	.560
1/2	702x8♦	.406	1.76	1.12	.670
7/8	702x14	.750	2.37	1.62	.937

♦MTO - Made To Order

BRASS

**Male Run Tee**  
(Ref. SAE No. 040424)

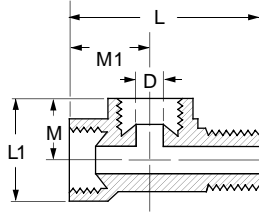
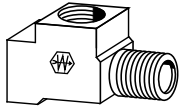

Tube O.D.	Male Pipe Thread	Catalog Number	D	L	L1	M	M1
3/16	1/8	752x3♦	.125	1.25	.62	.39	.53
1/4	1/8	752x4	.188	1.31	.69	.42	.56
5/16	1/8	752x5♦	.219	1.47	.75	.45	.62
3/8	1/4	752x6♦	.281	1.83	.94	.56	.75
1/2	3/8	752x8♦	.406	2.00	1.12	.67	.88

**Male Branch Tee**  
(Ref. SAE No. 040425)

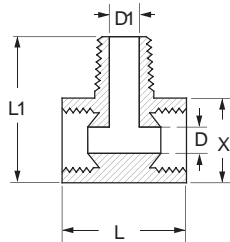
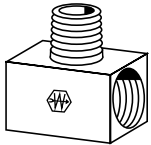

Tube O.D.	Male Pipe Thread	Catalog Number	D	D1	L	L1	X
3/16	1/8	602x3	.125	.219	.82	.84	.47
1/4	1/8	602x4	.188	.219	.84	.91	.53
5/16	1/8	602x5	.219	.219	.95	.97	.59
3/8	1/4	602x6	.281	.344	1.16	1.31	.75
1/2	3/8	602x8♦	.406	.406	1.39	1.47	.91

**Female Branch Tee**  
(Ref. SAE No. 040427)

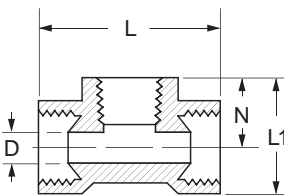
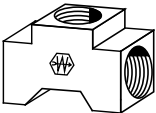

Tube O.D.	Fem. Pipe Thread	Catalog Number	D	L	L1	N
3/16	1/8	652x3	.125	1.10	.62	.39
1/4	1/8	652x4♦	.188	1.12	.69	.42
5/16	1/8	652x5♦	.219	1.26	.75	.45
3/8	1/4	652x6♦	.281	1.47	.94	.56
1/2	3/8	652x8♦	.406	1.75	1.12	.67

**Adapter Tee**  
(Female to Male Pipe on Run)

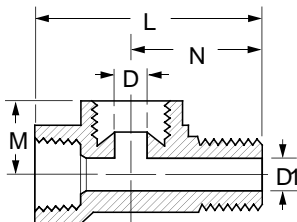
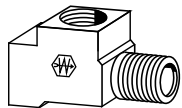

Tube O.D.	Male & Fem. Pipe Thread	Catalog Number	D	D1	L	M	N
3/16	1/8	552x3♦	.125	.219	1.22	.50	.64
1/4	1/8	552x4♦	.188	.219	1.22	.50	.64

♦MTO - Made To Order

# SAE 45° Flare

**Brass  
Fittings**

 Refer to safety information regarding proper selection of tubing and tube fittings on page 1.

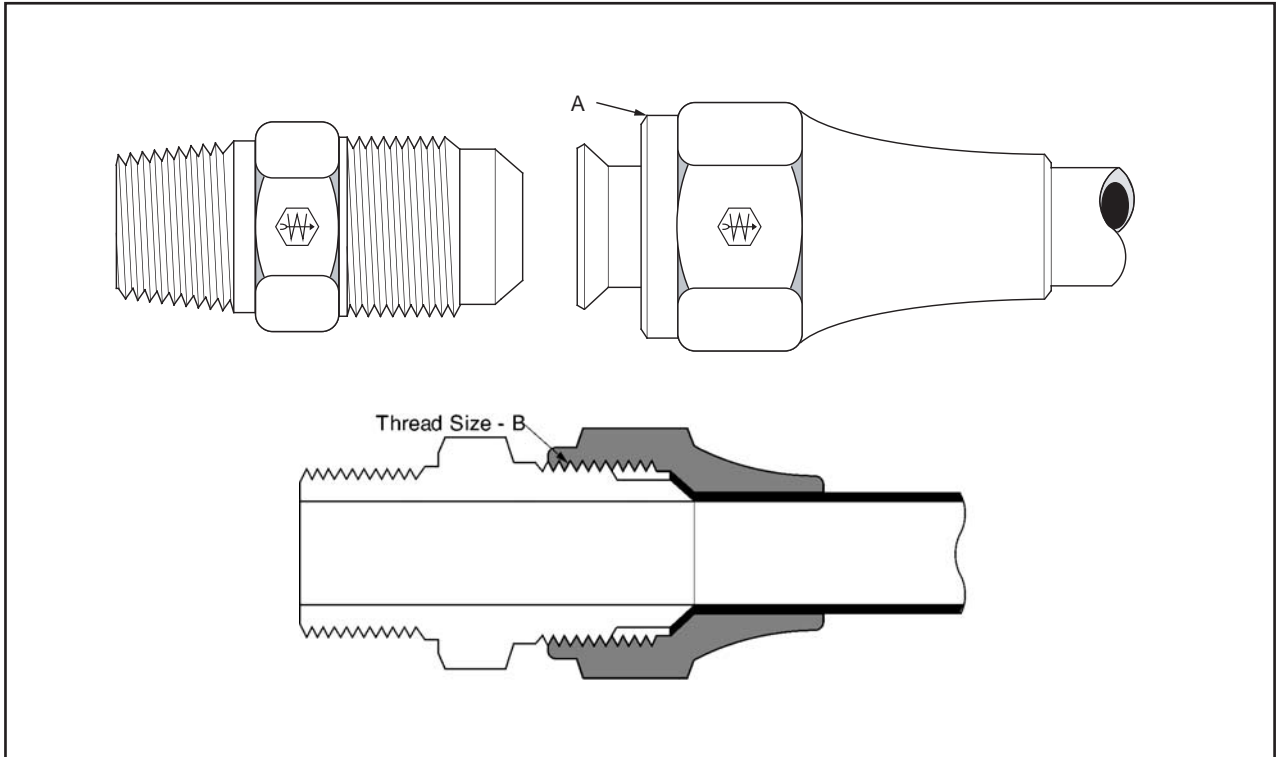

<b>Tube O.D.</b>	1/8	3/16	1/4	5/16	3/8	7/16	1/2	5/8	3/4
<b>Thread Size-B</b>	5/16-24	3/8-24	7/16-20	1/2-20	5/8-18	11/16-16	3/4-16	7/8-14	1-1/16-14

- Typical Application**  
 LP and natural gas, flammable liquids (special order), instrumentation, refrigeration, power steering, hydraulic and pneumatic systems.
- Pressure**  
 Working pressure up to 2000 psi depending on tube size. Will withstand burst pressure of standard tubing - up to 5000 psi with Bundy-weld (double flared) and 3500 psi with copper tubing, depending on size.
- Vibration**  
 Good resistance - use long nut when greater vibration resistance is required.
- Temperature Range**  
 -65°F to +250°F (-53°C to +121°C) range at maximum operating pressures.
- Material**  
 CA360 Brass.
- Used With**  
 Copper, brass, aluminum and steel hydraulic tubing that can be flared. See page 28-32 for material compatibility.
- Advantages**  
 Low cost and reusability, long or short nut. Good resistance to vibration.
- Conformance**  
 Listed by Underwriter's Laboratories (available on special order) for flammable liquids, refrigeration and gas. Meets specifications and standards of ASA, ASME, SAE and MS (Military Standards).
- How to Order**  
 Order individually by catalog number.
- NOTE**  
 Refer to current price list for availability of cataloged items. Configurations and dimensions subject to change without notice. Quotations of non-stock items available upon request. Additional information can be found in SAE J512.
- Assembly Instructions**
  - Cut tubing to desired length. Make sure all burrs are removed and the ends are cut square.
  - Slide nut on tube. Threaded end "A" of nut must face out.
  - Flare end of tube with a 45° flaring tool. See page 26 for flare data.
    - Measure flare diameter.
    - Examine flare for excessive thin out.
  - Lubricate threads and assemble to fitting body. Nut should be turned hand tight.
  - Tighten assembly with a wrench until a solid feeling is encountered. From that point, apply a one-sixth turn.

**NOTE:** Do not over-torque as it may damage the fitting or split the tubing at the flare.

**Label Set:** **W-8022** (adhesive)  
**CL-490** (non-adhesive)

BRASS

**Nut**  
(Ref. SAE No. 010110)

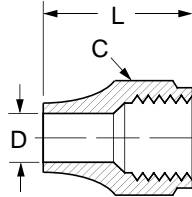
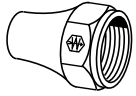

Tube O.D.	Catalog Number	Hex C	D	L
1/8	1110x2	3/8	.133	.50
3/16	1110x3	7/16	.195	.62
1/4	1110x4	9/16	.258	.75
5/16	1110x5	5/8	.320	.88
3/8	1110x6	3/4	.383	1.00
7/16	1110x7♦	13/16	.445	1.06
1/2	1110x8	7/8	.508	1.12
5/8	1110x10	1-1/16	.633	1.31
3/4	1110x12♦	1-1/4	.758	1.50

**Long Nut**  
(Ref. SAE No. 010111)

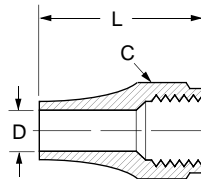
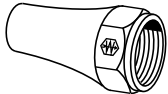

Tube O.D.	Catalog Number	Hex C	D	L
3/16	41x3	7/16	.195	.81
1/4	41x4	9/16	.258	.94
5/16	41x5	5/8	.320	1.12
3/8	41x6	3/4	.383	1.31
1/2	41x8	7/8	.508	1.62
5/8	41x10♦	1-1/16	.633	1.88

**Cap**

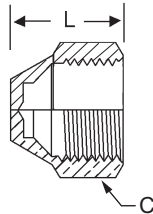
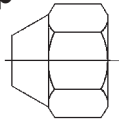

Tube O.D.	Catalog Number	Hex C	L
1/8	40x2	7/16	.40
3/16	40x3	1/2	.47
1/4	40x4	7/16	.53
5/16	40x5	5/8	.62
3/8	40x6	3/4	.69
1/2	40x8	7/8	.84
5/8	40x10	1-1/16	.97
3/4	40x12	1-5/16	1.09

**Plug**

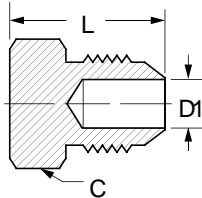
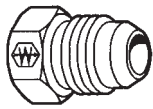

Tube O.D.	Catalog Number	Hex C	L	D1 (opt.)
1/8	39x2	5/16	.47	.079
3/16	39x3	3/8	.58	.126
1/4	39x4	7/16	.69	.189
5/16	39x5	1/2	.79	.220
3/8	39x6	5/8	.88	.282
1/2	39x8	3/4	1.06	.408
5/8	39x10	7/8	1.19	.502
3/4	39x12	1-1/16	1.31	.627

**Union**  
(Ref. SAE No. 010101)

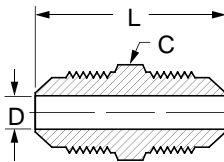

Tube O.D.	Catalog Number	Hex C	D	L
1/8	42x2♦	5/16	.078	.92
3/16	42x3	3/8	.125	1.06
1/4	42x4	7/16	.188	1.19
5/16	42x5	1/2	.219	1.34
3/8	42x6	5/8	.281	1.50
1/2	42x8	3/4	.406	1.81
5/8	42x10	7/8	.500	2.12
3/4	42x12♦	1-1/16	.625	2.44

**Male Connector**  
(Ref. SAE No. 010102)

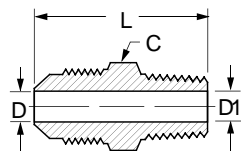

Tube O.D.	Male Pipe Thread	Catalog Number	Hex C	D	D1	L
1/8	1/8	48x2	7/16	.078	.219	.90
3/16	1/8	48x3	7/16	.125	.219	1.00
1/4	1/8	48x4	7/16	.188	.188	1.06
1/4	1/4	48x4x4	9/16	.188	.312	1.26
5/16	1/8	48x5	1/2	.219	.219	1.16
5/16	1/4	48x5x4	9/16	.219	.219	1.34
3/8	1/8	48x6x2	5/8	.281	.219	1.25
3/8	1/4	48x6	5/8	.281	.281	1.44
3/8	3/8	48x6x6	11/16	.281	.281	1.44
3/8	1/2	48x6x8	7/8	.281	.562*	1.69
7/16	1/4	48x7♦	11/16	.312	.312	1.53
1/2	1/4	48x8x4	3/4	.406	.312	1.62
1/2	3/8	48x8	3/4	.406	.406	1.62
1/2	1/2	48x8x8	7/8	.406	.562	1.81
5/8	3/8	48x10x6	7/8	.500	.406	1.81
5/8	1/2	48x10	7/8	.500	.500	2.00
3/4	1/2	48x12	1-1/16	.625	.562	2.18
3/4	3/4	48x12x12	1-1/16	.625	.625	2.18

\*Counterbore is optional.

# SAE 45° Flare

**Brass  
Fittings**

## Female Connector (Ref. SAE No. 010103)

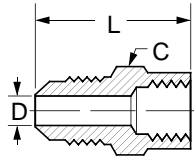
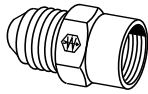

Tube O.D.	Fem. Pipe Thread	Catalog Number	Hex C	D	L
3/16	1/8	46x3♦	9/16	.125	.97
1/4	1/8	46x4	9/16	.188	1.03
1/4	1/4	46x4x4	11/16	.188	1.25
5/16	1/8	46x5	9/16	.219	1.06
5/16	1/4	46x5x4♦	11/16	.219	1.28
3/8	1/8	46x6x2♦	5/8	.281	1.12
3/8	1/4	46x6	11/16	.281	1.31
3/8	3/8	46x6x6	13/16	.281	1.38
3/8	1/2	46x6x8♦	1	.281	1.62
1/2	1/4	46x8x4♦	3/4	.406	1.41
1/2	3/8	46x8	13/16	.406	1.50
1/2	1/2	46x8x8♦	1	.406	1.75
5/8	1/2	46x10♦	1	.500	1.81

## Male Ball Check Connector

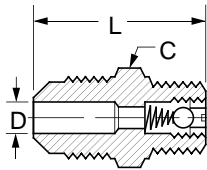
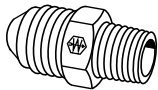

Ball & Spring position may be reversed to change flow/check direction. Min pressure 3 psi.

Tube O.D.	Male Pipe Thread	Catalog Number	Hex C	D	L
1/4	1/8	43x4	7/16	.125	1.06
5/16	1/8	43x5♦	1/2	.125	1.16
3/8	1/4	43x6	5/8	.219	1.31

## 45° Male Elbow (Ref. SAE No. 010302)

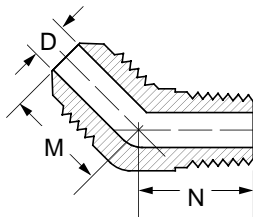
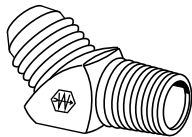

Tube O.D.	Male Pipe Thread	Catalog Number	D	M	N
1/4	1/8	54x4	.188	.67	.64
1/4	1/4	54x4x4	.188	.73	.87
5/16	1/8	54x5	.219	.78	.64
3/8	1/4	54x6	.281	.89	.86
3/8	3/8	54x6x6♦	.281	.93	.95
1/2	3/8	54x8	.406	1.06	.95
1/2	1/2	54x8x8	.406	1.12	1.17
5/8	1/2	54x10	.500	1.23	1.17
5/8	3/8	54x10x6	.500	1.23	.98

## Female 45° Flare Swivel to Male SAE 45° Elbow (Steel)

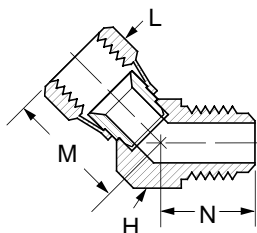
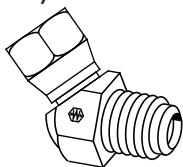

Tube O.D.	Catalog Number	M	N	Hex H	Hex L
3/8	9154x6x6	1.14	1.40	3/4	3/4
1/2	9154x8x8	1.04	1.76	1	7/8
5/8	9154x10x10	1.16	1.92	1-1/4	1

♦MTO - Made To Order

BRASS

**Restriction Pipe Adapter  
(With .0625 Orifice)**

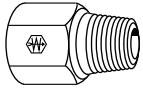

Male and  
Fem. Pipe  
Thread

Catalog  
Number

1/8

1512

**Carburetor to  
Fuel Line Adapter  
(Ford)**

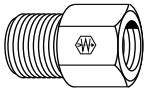

Male  
Pipe Thread

Catalog  
Number

1/4

1/8

1-2-20

1513

For use with 59x4

**Fuel Line Adapter**

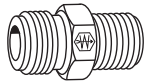

Inv.  
Tube  
Size

Male  
Pipe  
Thread

Catalog  
Number

1/2-20

1/8

1514

**AC Type Adapter**



Tube  
Size

S.A.E.  
Tube  
Size

Catalog  
Number

1/4

1/4

1521

**Adapter SAE 45°  
Flare to Inv. Flare**

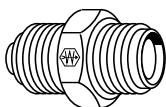

SAE  
Tube  
Size

Inverted  
Male

Catalog  
Number

1/4

3/16

1518

1/4

1/4

1522

3/8

5/16

1553

3/8

3/8

1563

3/8

7/16

1554

# SAE 45° Flare

**Brass  
Fittings**

## Union Elbow (Ref. SAE No. 010201)

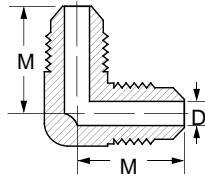
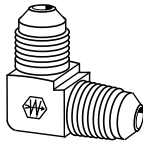

Tube O.D.	Catalog Number	D	M
1/4	55x4♦	.188	.86
5/16	55x5♦	.219	.91
3/8	55x6♦	.281	1.04
1/2	55x8	.406	1.20
5/8	55x10♦	.500	1.41

## Male Elbow (Ref. SAE No. 010202)

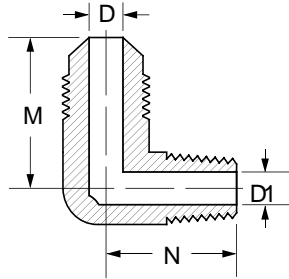
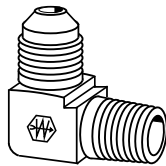

Tube O.D.	Male Pipe Thread	Catalog Number	D	D1	M	N
1/8	1/8	49x2	.078	.219	.62	.69
3/16	1/8	49x3	.125	.219	.75	.75
1/4	1/8	49x4	.188	.219	.81	.76
1/4	1/4	49x4x4	.188	.312	.88	.94
1/4	3/8	49x4x6	.188	.375	.94	1.03
5/16	1/8	49x5	.219	.219	.91	.78
5/16	1/4	49x5x4	.219	.312	.95	.92
3/8	1/8	49x6x2	.281	.219	1.03	.91
3/8	1/4	49x6	.281	.312	.97	1.06
3/8	3/8	49x6x6	.281	.406	1.06	1.09
3/8	1/2	49x6x8	.281	.438	1.16	1.28
7/16	1/4	49x7♦	.312	.312	1.12	1.06
1/2	1/4	49x8x4	.406	.281	1.22	1.19
1/2	3/8	49x8	.406	.406	1.22	1.12
1/2	1/2	49x8x8	.406	.406	1.26	1.36
5/8	3/8	49x10x6	.500	.410	1.41	1.23
5/8	1/2	49x10	.500	.562	1.41	1.38
3/4	1/2	49x12	.625	.531	1.62	1.50
3/4	3/4	49x12x12	.625	.750	1.59	1.62

## Female Elbow (Ref. SAE No. 010203)

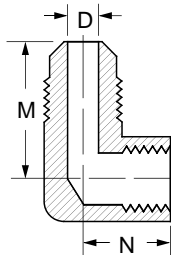
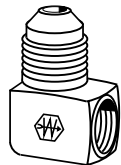

Tube O.D.	Fem. Pipe Thread	Catalog Number	D	M	N
3/16	1/8	50x3♦	.125	.81	.44
1/4	1/8	50x4	.188	.88	.47
1/4	1/4	50x4x4	.188	.97	.66
5/16	1/8	50x5♦	.219	.94	.47
5/16	1/4	50x5x4♦	.219	1.03	.66
3/8	1/4	50x6	.281	1.09	.69
3/8	3/8	50x6x6♦	.281	1.16	.69
1/2	3/8	50x8♦	.406	1.28	.75
1/2	1/2	50x8x8♦	.406	1.38	.94
5/8	1/2	50x10	.500	1.50	1.00

## 90° Elbow 45° Female Swivel to SAE 45° (Steel)

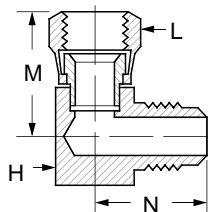

Tube O.D.	Catalog Number	M	N	Hex H	Hex L
3/8	9151x6x6	1.09	1.00	3/4	3/4
1/2	9151x8x8	1.43	1.25	1	7/8
5/8	9151x10x10	1.60	1.44	1-1/4	1

♦MTO - Made To Order

**Union Tee**  
(Ref. SAE No. 010401)

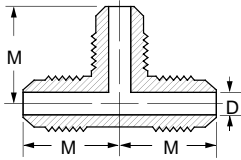
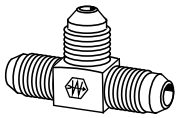

Tube O.D.	Catalog Number	D	M
3/16	44x3♦	.125	.73
1/4	44x4	.188	.86
5/16	44x5♦	.219	.89
3/8	44x6♦	.281	1.04
1/2	44x8	.406	1.20
5/8	44x10♦	.500	1.42

**Male Run Tee**  
(Ref. SAE No. 010424)

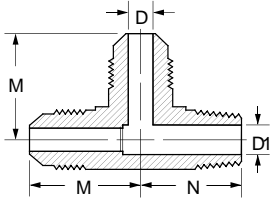
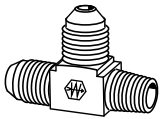

Tube O.D.	Male Pipe Thread	Catalog Number	D	D1 Opt.	M	N
3/16	1/8	51x3♦	.125	.219	.73	.73
1/4	1/8	51x4	.188	.219	.86	.76
5/16	1/8	51x5♦	.219	.219	.89	.76
5/16	1/4	51x5x4x5♦	.219	.312	.97	.97
3/8	1/4	51x6♦	.281	.281	1.04	1.04
3/8	3/8	51x6x6x6♦	.281	.406	1.06	1.09
1/2	3/8	51x8♦	.406	.406	1.20	1.10
1/2	1/2	51x8x8x8♦	.406	.562	1.28	1.38
5/8	1/2	51x10♦	.500	.500	1.42	1.38

**Male Branch Tee**  
(Ref. SAE No. 010425)

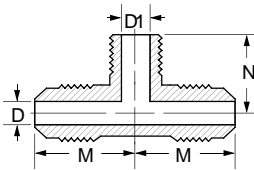
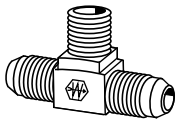

Tube O.D.	Male Pipe Thread	Catalog Number	D	D1	M	N
3/16	1/8	45x3♦	.125	.219	.75	.75
1/4	1/8	45x4	.188	.219	.81	.78
1/4	1/4	45x4x4x4♦	.188	.312	.91	.94
5/16	1/8	45x5♦	.219	.219	.91	.78
5/16	1/4	45x5x5x4♦	.219	.312	.97	.94
3/8	1/4	45x6♦	.281	.344	1.00	1.06
3/8	3/8	45x6x6x6♦	.281	.406	1.06	1.09
1/2	3/8	45x8♦	.406	.406	1.22	1.12
1/2	1/2	45x8x8x8♦	.406	.562	1.28	1.38
5/8	1/2	45x10♦	.500	.562	1.41	1.38
3/4	1/2	45x12♦	.625	.562	1.62	1.50

**Adapter Tee**  
(Female to Male Pipe on Run)

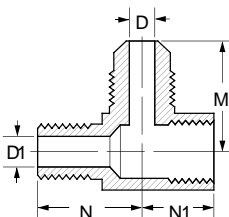
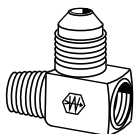

Tube O.D.	M&F Pipe Thread	Catalog Number	D	D1	M	N	N1
3/16	1/8	56x3♦	.125	.188	.78	.75	.47
1/4	1/8	56x4♦	.188	.188	.78	.76	.46



# Compression

**Brass  
Fittings**

 Refer to safety information regarding proper selection of tubing and tube fittings on page 1.

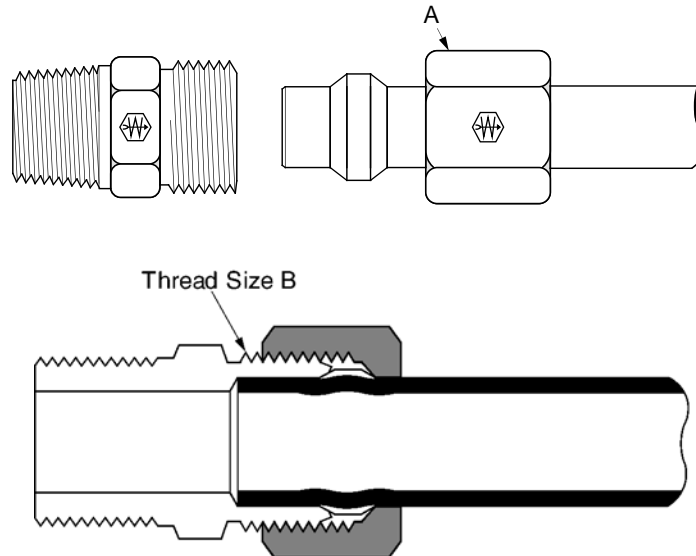

Tube O.D.	1/8	3/16	1/4	5/16	3/8	7/16	1/2	5/8	3/4	1
Thread Size-B	5/16-24	3/8-24	7/16-24	1/2-24	9/16-24	5/8-24	11/16-20	13/16-18	1-18	1-1/4-18

• **Typical Application**

Instrumentation, hydraulic and pneumatic systems.

• **Pressure**

Working pressure up to 2000 psi with a 4:1 safety factor depending on tube size. When using plastic tubing, use the working pressure for type used.

• **Vibration**

Fair resistance - use long nut when greater vibration resistance is needed.

• **Temperature Range**

-65°F to +250°F (-53°C to +121°C) with metal tubing. When using compatible plastic tubing do not exceed the tubing temperature range. (Refer to tubing temperature range.)

• **Material**

CA360 Brass.

• **Used With**

Aluminum, copper and Weatherhead plastic tubing.  
Plastic tubing, except for PT230, requires 2030x insert. Not recommended for steel tubing. See page 28-32 for material compatibility, and pages 33-34 for plastic tubing.

• **Advantages**

Low cost. Easy to assemble, no flaring. Available with long or short nut. Broad selection of styles and sizes.

• **Conformance**

Listed by Underwriter's Laboratories (available on special order) for flammable liquids. Meets specifications and standards of ASA, ASME and SAE.

• **How to Order**

Compression fittings are ordered as complete assemblies (body, nut and sleeve). To order assembly supplied with long nuts, simply add the prefix "1" to the catalog number. Example: 68x4 with long nut becomes 168x4. Nuts and sleeves can be ordered separately by catalog number. To order bodies only (less nut and sleeve), prefix catalog number with letter "B". Example: B68x4.

• **NOTE**

Refer to current price list for availability of cataloged items. Quotations and delivery of non-stock items supplied on request. Configurations and dimensions subject to change without notice. Additional information can be found in SAE J512.

• **Assembly Instructions**

1. Cut tubing to desired length.
2. Slide nut and then sleeve on tube. Threaded end "A" of nut must face toward fitting.
3. Insert tubing into fitting body. Be sure tubing is bottomed on fitting shoulder.
4. Lubricate threads and assemble nut to fitting body.
5. Tighten nut hand tight. From that point, tighten with a wrench the number of turns indicated in the chart below.

Tube Size	Additional Turns From Hand Tight
1/8" thru 1/4"	1-1/4
5/16"	1-3/4
3/8" thru 1"	2-1/4

Label Set: **W-8022** (adhesive)  
**CL-490** (non-adhesive)

BRASS

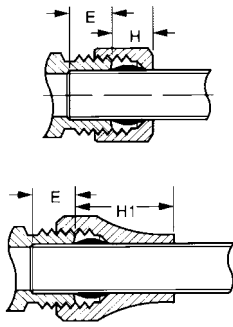

NOTE: H and H1 are hand tight.

Tube O.D.	E Tube Stop Depth	H	H1 (Long Nut)
1/8	.19	.23	–
3/16	.22	.25	.47
1/4	.25	.29	.56
5/16	.28	.30	.66
3/8	.31	.27	.70
1/2	.38	.42	.88
5/8	.38	.42	.92
3/4	.44	.49	1.18

## Tube Support for Plastic Tubing

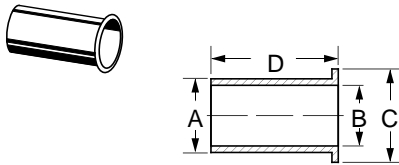

Use only with PT200 and PT240 Tubing.

\* For Tubing with .126 I.D./0.062 wall thickness.

\*\* For tubing with .170 I.D./0.040 wall thickness.

Tube O.D.	Catalog Number	Dia. A	Dia. B	Dia. C	Length D
1/4	2030x4*	1/8	3/32	11/64	19/32
1/4	2030x44**	11/64	9/64	7/32	17/32
5/16	2030x5	3/16	5/32	15/64	5/8
3/8	2030x6	1/4	7/32	11/32	41/64
1/2	2030x8	3/8	11/32	7/16	13/16
5/8	2030x10	1/2	29/64	35/64	13/16
3/4	2030x12	9/16	33/64	11/16	1-1/32
1	2030x16♦	3/4	45/64	51/64	1-1/4

## Compression Sleeve (Ref. SAE No. 060115)

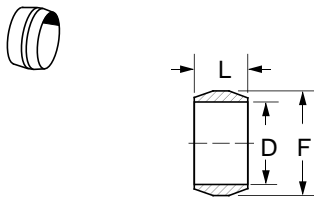

Tube O.D.	Catalog Number	D	F	L
1/8	60x2	.13	.19	.19
3/16	60x3	.19	.27	.22
1/4	60x4	.26	.34	.25
5/16	60x5	.32	.41	.25
3/8	60x6	.38	.47	.25
7/16	60x7	.44	.53	.31
1/2	60x8	.51	.59	.38
5/8	60x10	.63	.72	.38
3/4	60x12♦	.76	.88	.44
1	60x16♦	1.02	1.17	.56

## Nut (Ref. SAE No. 060110)

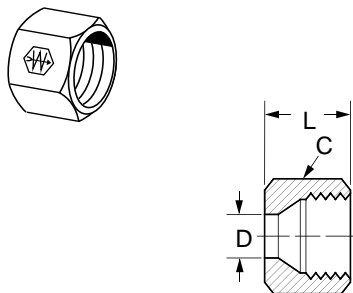

Tube O.D.	Catalog Number	Hex C	D	L
1/8	61x2	3/8	.13	.38
3/16	61x3	7/16	.19	.41
1/4	61x4	1/2	.26	.44
5/16	61x5	9/16	.32	.44
3/8	61x6	5/8	.38	.47
7/16	61x7	11/16	.44	.50
1/2	61x8	13/16	.51	.62
5/8	61x10	15/16	.63	.62
3/4	61x12♦	1-3/16	.76	.69

# Compression

## Brass Fittings

### Long Nut

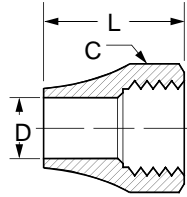
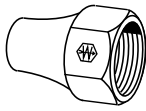

Tube O.D.	Catalog Number	Hex C	D	L
3/16	1611x3	7/16	.193	.62
1/4	1611x4	9/16	.260	.75
5/16	1611x5♦	5/8	.320	.84
3/8	1611x6	11/16	.380	.88
1/2	1611x8♦	13/16	.510	1.06
5/8	1611x10♦	15/16	.637	1.08
3/4	1611x12♦	1-1/8	.760	1.38
1	1611x16♦	1-3/8	1.020	1.59

### Bulkhead Nut

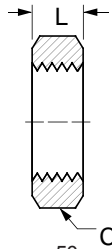
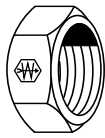

Used on 74x Bulkhead Unions. Ref. page 50.

Tube O.D.	Catalog Number	Hex C	L	Thread Size
1/4	0102x4	9/16	.25	7/16-24
5/16	0102x5	5/8	.25	1/2-24
3/8	0102x6	11/16	.25	9/16-24
1/2	0102x8	15/16	.38	11/16-20

### Union (Ref. SAE No. 060101BA)

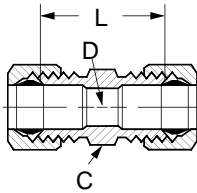
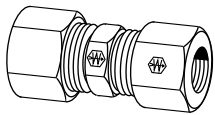

Assembly with long nut 162x

Tube O.D.	Catalog Number	Hex C	D	L
1/8	62x2	5/16	.094	.66
3/16	62x3	3/8	.125	.76
1/4	62x4	7/16	.188	.79
5/16	62x5	1/2	.250	.88
3/8	62x6	9/16	.312	.97
1/2	62x8	11/16	.406	1.10
5/8	62x10	13/16	.500	1.25
3/4	62x12♦	1	.562	1.44

### Male Connector (Ref. SAE No. 060102BA)

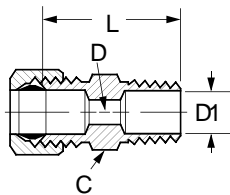
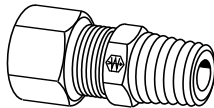

Assembly with long nut 168x

\*Available only as assembly with long nut.

Tube O.D.	Male Pipe Thread	Catalog Number	Hex C	D	D1 Opt.	L
1/8	1/16	68x2x1	3/8	.094	-	.78
1/8	1/8	68x2	7/16	.094	.094	.78
3/16	1/8	68x3	7/16	.125	.125	.84
3/16	1/4	68x3x4♦	9/16	.125	.125	1.03
1/4	1/8	68x4	7/16	.188	.188	.88
1/4	1/4	68x4x4	9/16	.188	.312	1.06
5/16	1/8	68x5	1/2	.250	.234	.91
5/16	1/4	68x5x4	9/16	.250	.250	1.09
3/8	1/8	68x6x2	9/16	.312	.250	.97
3/8	1/4	68x6	9/16	.312	.312	1.17
3/8	3/8	68x6x6	11/16	.312	.312	1.16
3/8	1/2	68x6x8	7/8	.312	.562	1.34
7/16	1/4	68x7♦	5/8	.312	.312	1.19
1/2	1/4	68x8x4	11/16	.406	.281	1.22
1/2	3/8	68x8	11/16	.406	.406	1.22
1/2	1/2	68x8x8	7/8	.406	.406	1.41
5/8	1/2	68x10	7/8	.500	.500	1.50
3/4	1/2	68x12♦	1	.562	.562	1.62
3/4	3/4	68x12x12♦	1-1/16	.562	.875	1.62
1	1	168x16♦*	1-3/8	.875	-	2.00

♦MTO - Made To Order

BRASS

## Female Connector (Ref. SAE No. 060103BA)

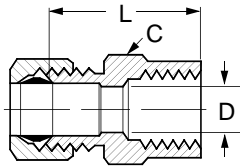
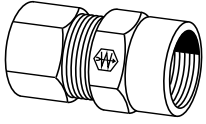

Tube O.D.	Fem. Pipe Thread	Catalog Number	Hex C	D	L
1/8	1/8	66x2	9/16	.094	.75
3/16	1/8	66x3	9/16	.125	.78
1/4	1/8	66x4	9/16	.188	.78
1/4	1/4	66x4x4	11/16	.188	1.03
5/16	1/8	66x5	9/16	.250	.81
5/16	1/4	66x5x4♦	11/16	.250	1.03
3/8	1/8	66x6x2	9/16	.312	.84
3/8	1/4	66x6	11/16	.312	1.06
1/2	3/8	66x8	13/16	.406	1.12
5/8	1/2	66x10♦	1	.500	1.38

Assembly with long nut **166x**

## Male Ball Check Connector

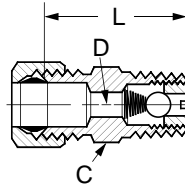
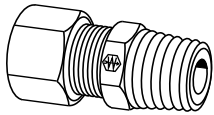

Tube O.D.	Male Pipe Thread	Catalog Number	Hex C	D	L
3/16	1/8	63x3♦	7/16	.125	.84
1/4	1/8	63x4	7/16	.125	.88
5/16	1/8	63x5♦	1/2	.125	.91
3/8	1/4	63x6	9/16	.219	1.16

Assembly with long nut **163x**. Min. working pressure 3 psi. Ball and spring position may be reversed to change flow/check direction. Ball check valves are neither tested nor adjusted prior to sale.

## Bulkhead Union

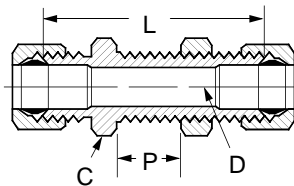
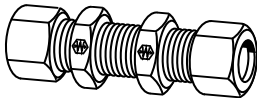

Tube O.D.	Catalog Number	Hex C	D	L	Max. P
1/4	74x4	9/16	.188	1.57	.52
5/16	74x5♦	5/8	.250	1.68	.55
3/8	74x6♦	11/16	.312	1.76	.55
1/2	74x8♦	13/16	.406	1.93	.52

Assembly with long nut **174x**  
For Bulkhead Nuts, ref. page 49, included with assembly.

### Male Elbow (Ref. SAE No. 060202BA)

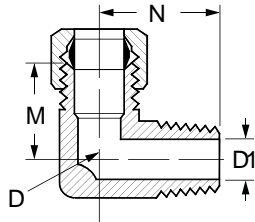
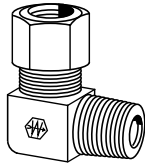

Assembly with long nut **169x**  
\*Available only as assembly with long nuts

Tube O.D.	Male Pipe Thread	Catalog Number	D	D1	M	N
1/8	1/16	<b>69x2x1</b>	.104	.125	.54	.66
1/8	1/8	<b>69x2</b>	.094	.219	.60	.67
3/16	1/8	<b>69x3</b>	.125	.219	.62	.69
1/4	1/8	<b>69x4</b>	.188	.219	.62	.75
1/4	1/4	<b>69x4x4</b>	.188	.188	.62	.75
5/16	1/8	<b>69x5</b>	.250	.234	.62	.75
5/16	1/4	<b>69x5x4</b>	.250	.312	.69	.84
3/8	1/8	<b>69x6x2</b>	.312	.234	.69	.69
3/8	1/4	<b>69x6</b>	.312	.344	.75	.94
3/8	3/8	<b>69x6x6</b>	.312	.438	.84	.94
3/8	1/2	<b>69x6x8</b>	.312	.531	1.06	1.12
7/16	1/4	<b>69x7*</b>	.312	.312	.84	1.00
1/2	1/4	<b>69x8x4</b>	.406	.312	.84	.94
1/2	3/8	<b>69x8</b>	.406	.406	.94	1.12
1/2	1/2	<b>69x8x8</b>	.406	.531	.94	1.31
5/8	1/2	<b>69x10</b>	.500	.562	1.06	1.31
3/4	1/2	<b>69x12*</b>	.562	.562	1.19	1.50
3/4	3/4	<b>69x12x12*</b>	.562	.562	1.19	1.31
1	1	<b>169x16*</b>	.875	.938	1.31	1.62

### Union Elbow (Ref. SAE No. 060201BA)

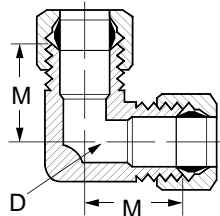
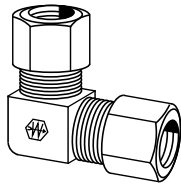

Assembly with long nut **165x**

Tube O.D.	Catalog Number	D	M
3/16	<b>65x3*</b>	.125	.59
1/4	<b>65x4</b>	.188	.60
5/16	<b>65x5</b>	.250	.62
3/8	<b>65x6</b>	.312	.73
1/2	<b>65x8</b>	.406	.94

### Female Elbow (Ref. SAE No. 060203BA)

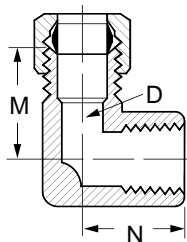
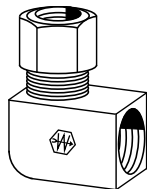

Assembly with long nut **170x**

Tube O.D.	Fem. Pipe Thread	Catalog Number	D	M	N
3/16	1/8	<b>70x3</b>	.125	.69	.56
1/4	1/8	<b>70x4</b>	.188	.69	.56
5/16	1/8	<b>70x5*</b>	.250	.69	.56
3/8	1/4	<b>70x6*</b>	.312	.81	.75
1/2	3/8	<b>70x8*</b>	.406	1.00	.88
5/8	1/2	<b>70x10*</b>	.500	1.06	1.00

\*MTO - Made To Order

**Union Tee**  
(Ref. SAE No. 060401BA)

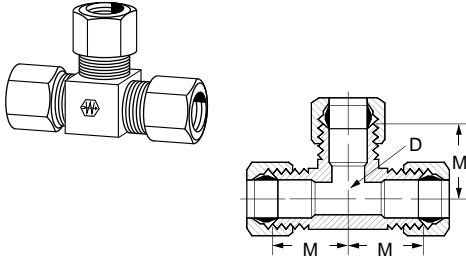

Assembly with long nut **164x**

Tube O.D.	Catalog Number	D	M
3/16	<b>64x3</b>	.125	.60
1/4	<b>64x4</b>	.188	.62
5/16	<b>64x5</b>	.250	.60
3/8	<b>64x6</b>	.312	.73
1/2	<b>64x8</b>	.406	.94

**Male Run Tee**  
(Ref. SAE No. 060424BA)

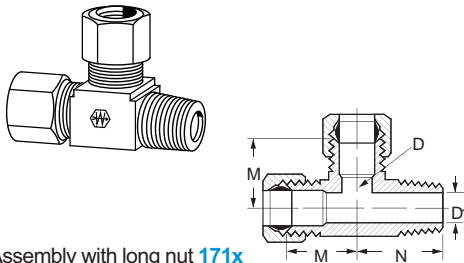

Assembly with long nut **171x**  
\* Optional Counterbore

Tube O.D.	Male Pipe Thread	Catalog Number	D	D1	M	N
3/16	1/8	<b>71x3</b>	.125	.219*	.64	.68
1/4	1/8	<b>71x4</b>	.188	.219*	.64	.73
1/4	1/4	<b>71x4x4x4*</b>	.188	.281*	.66	.80
5/16	1/8	<b>71x5*</b>	.250	.219*	.65	.72
3/8	1/4	<b>71x6</b>	.312	.344*	.75	.94
1/2	3/8	<b>71x8*</b>	.406	.406*	.97	1.09

**Male Branch Tee**  
(Ref. SAE No. 060425BA)

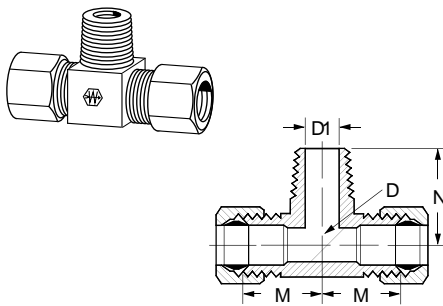

Assembly with long nut **172x**

Tube O.D.	Male Pipe Thread	Catalog Number	D	D1	M	N
3/16	1/8	<b>72x3*</b>	.125	.219	.62	.69
1/4	1/8	<b>72x4</b>	.188	.219	.64	.73
1/4	1/4	<b>72x4x4x4</b>	.188	.281	.78	.85
5/16	1/8	<b>72x5</b>	.250	.234	.66	.70
3/8	1/4	<b>72x6</b>	.312	.344	.78	.91
1/2	3/8	<b>72x8</b>	.406	.406	.96	1.09

**Adapter Tee**  
(Female to Male Pipe on Run)

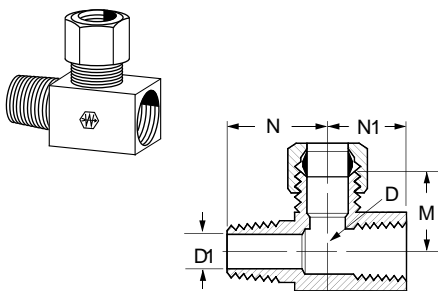

Assembly with long nut **176x**

Tube O.D.	M&F Pipe Thread	Catalog Number	D	D1	M	N	N1
1/8	1/8	<b>76x2*</b>	.094	.219	.59	.56	.44
3/16	1/8	<b>76x3*</b>	.125	.219	.59	.56	.44
1/4	1/8	<b>76x4*</b>	.188	.219	.59	.63	.47

\*MTO - Made To Order

 Refer to safety information regarding proper selection of tubing and tube fittings on page 1.

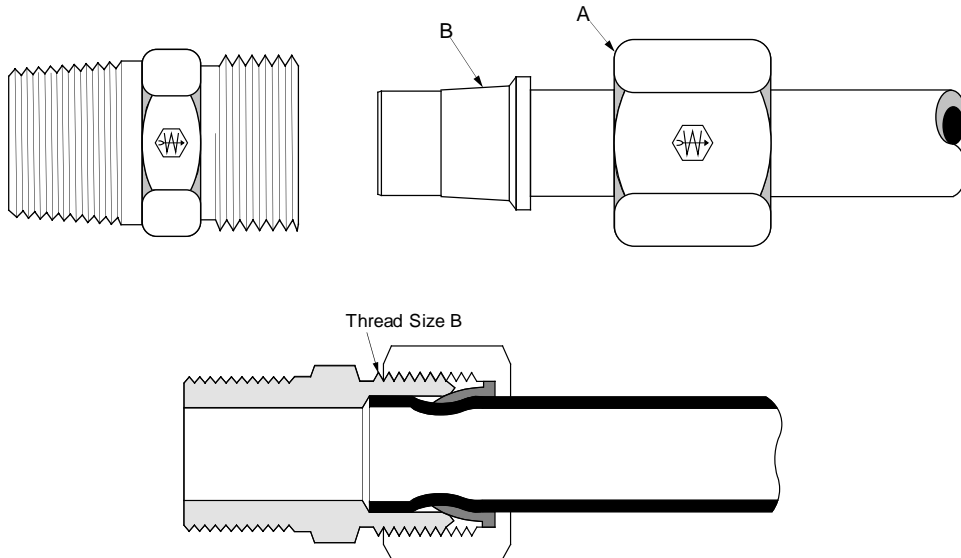

<b>Tube O.D.</b>	1/8	3/16	1/4	5/16	3/8	7/16	1/2	5/8	3/4	1
<b>Thread Size-B</b>	5/16-24	3/8-24	7/16-24	1/2-24	9/16-24	5/8-24	11/16-20	13/16-18	1-18	1-1/4-18

- **Typical Application**  
Instrumentation, hydraulic and pneumatic systems.
- **Pressure**  
Working pressure up to 2000 psi with a 4:1 safety factor depending on tube size. When using plastic tubing, use the working pressure for type used.
- **Vibration**  
Good resistance - use long nut when greater vibration resistance is needed.
- **Temperature Range**  
-65°F to +250°F (-53°C to +121°C) with metal tubing. When using compatible plastic tubing do not exceed the tubing temperature range. (Refer to tubing temperature range.)
- **Material**  
CA360 Brass.
- **Used With**  
Aluminum, copper and Weatherhead plastic tubing. Plastic tubing, except for PT230, requires 2030x insert. Not recommended for steel tubing. See page 28-32 for material compatibility, and pages 33-34 for plastic tubing.
- **Advantages**  
Selfaligning - no need to disassemble fitting to line up sleeve on tube. Low cost. Easy to assemble, no flaring. Available with long or short nut. Broad selection of styles and sizes.
- **Conformance**  
An exclusive item with Weatherhead, user approvals only.
- **How to Order**  
Selfalign fittings are ordered as complete assemblies (body, nut and sleeve). To order assembly supplied with long nuts, simply add the prefix "1" to the catalog number. Example: 681x4 with long nut becomes 1681x4. Nuts and sleeves can be ordered separately by catalog number. To order bodies only (less nut and sleeve), prefix catalog number with the letter "B" and drop suffix number. Example: B68x4.
- **NOTE**  
Refer to current price list for availability of catalog items. Quotations and delivery of non-stock items supplied on request. Configurations and dimensions subject to change without notice.
- **Assembly Instructions**

  1. Cut tubing to desired length.
  2. Slide nut and then sleeve on tube. Threaded end of nut "A" and small end of sleeve "B" must face toward fitting.
  3. Insert tubing into fitting body. Be sure tubing is bottomed on fitting shoulder.
  4. Lubricate threads and assemble nut to fitting body.
  5. Tighten with wrench to the "ring grip" point.
    - a. Ring Grip is the point when the cutting edge of the sleeve grips the tube. This is determined by turning tube slowly but firmly by hand while tightening the nut with a wrench until tube can no longer be turned by hand and a sharp increase in torque is noticed.
  6. Tighten additional turns past "ring grip" as indicated on chart. Ref. to page 45.

**Label Set:** CL-500 (non-adhesive)

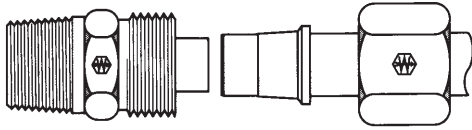

**SELFALIGN® ASSEMBLY DATA CHART**

Fitting Size	Annealed Copper and Soft Aluminum Tubing		Nylon Tubing			
			Type "T" Thin Wall		Type "H" Thick Wall	
	Wall	Turns*	Wall	Turns*	Wall	Turns*
2	.030	1-1/3	—	—	—	—
3	.030	1-1/3	.023	1-2/3	.039	1-1/3
4	.030	1-2/3	.030	2	.050	1-2/3
5	.032	1-2/3	.036	1-2/3	.062	2-2/3
6	.032	2	.040	1-2/3	.075	2
8	.032	2	—	—	—	—
10	.035	2	—	—	—	—
12	.049	2	—	—	—	—
16	.065	2-1/4	—	—	—	—

\*Turns from "Ring Grip".

Ring Grip is the point when the cutting edge of the sleeve grips the tube. This is determined by turning tube slowly but firmly by hand while tightening the nut with a wrench until tube can no longer be turned by hand and a sharp increase in torque is noted.

**NUT ASSEMBLY COMPARISON**

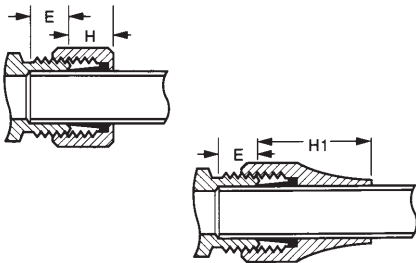

Tube O.D.	E Tube Stop Depth	H (Std. Nut)	H1 (Long Nut)
1/8	.19	.24	—
3/16	.22	.25	.49
1/4	.25	.35	.61
5/16	.28	.30	.70
3/8	.31	.31	.75
1/2	.38	.36	.83
5/8	.38	.41	.92
3/4	.44	.41	1.14

**NOTE:** H and H1 are hand tight

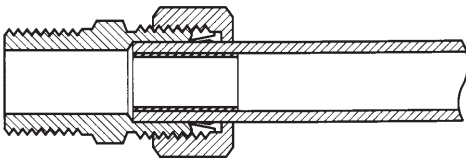

Illustration shows Selfalign® fitting used with soft plastic tubing and brass insert.

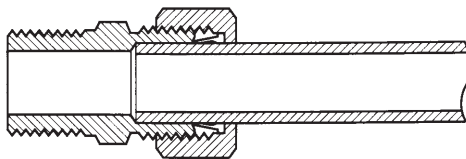
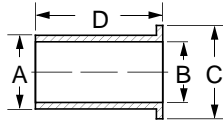

Illustration shows Selfalign® fitting used on rigid plastic tubing, no insert.



### Tube Supports for Plastic Tubing



Use only with PT200 and PT240 Tubing.

\* For tubing with .126 I.D./ .062 wall.

\*\* For tubing with .170 I.D./ .040 wall.

Tube O.D.	Catalog Number	Dia. A	Dia. B	Dia. C	Length D
1/4	2030x4*	1/8	3/32	11/64	19/32
1/4	2030x44**	11/64	9/64	7/32	17/32
5/16	2030x5	3/16	5/32	15/64	5/8
3/8	2030x6	1/4	7/32	11/32	41/64
1/2	2030x8	3/8	11/32	7/16	13/16
5/8	2030x10	1/2	29/64	35/64	13/16
3/4	2030x12	9/16	33/64	11/16	1-1/32
1	2030x16+	3/4	45/64	51/64	1-1/4

### Sleeve

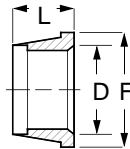

Tube O.D.	Catalog Number	D	F	L
1/8	601x2	.130	.25	.20
3/16	601x3	.193	.31	.20
1/4	601x4	.256	.38	.26
5/16	601x5	.318	.44	.26
3/8	601x6	.381	.50	.26
1/2	601x8	.507	.62	.30
5/8	601x10	.630	.72	.36
3/4	601x12	.755	.88	.38
1	601x16	1.005	1.19	.50

### Nut

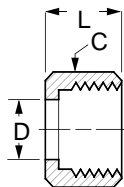

Tube O.D.	Catalog Number	Hex C	D	L
1/8	611x2	3/8	.14	.38
3/16	611x3	7/16	.19	.38
1/4	611x4	1/2	.26	.44
5/16	611x5	9/16	.32	.44
3/8	611x6	5/8	.38	.44
1/2	611x8	13/16	.51	.52
5/8	611x10	15/16	.64	.56
3/4	611x12	1-3/16	.76	.56

### Long Nut

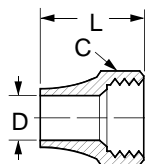
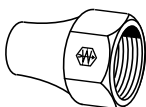

Tube O.D.	Catalog Number	Hex C	D	L
3/16	1611x3	7/16	.193	.62
1/4	1611x4	9/16	.260	.75
5/16	1611x5+	5/8	.320	.84
3/8	1611x6	11/16	.380	.88
1/2	1611x8+	13/16	.510	1.06
5/8	1611x10+	15/16	.637	1.08
3/4	1611x12+	1-1/8	.760	1.38
1	1611x16+	1-3/8	1.020	1.59

+MTO - Made To Order

**Bulkhead Nut**

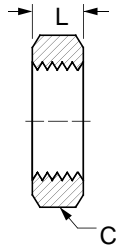
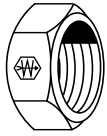

Use on **741x** Bulkhead Unions. Ref. page 57.

Tube O.D.	Catalog Number	Hex C	L
1/4	<b>0102x4</b>	9/16	.25
5/16	<b>0102x5</b>	5/8	.25
3/8	<b>0102x6</b>	11/16	.25
1/2	<b>0102x8</b>	15/16	.38

**Union**

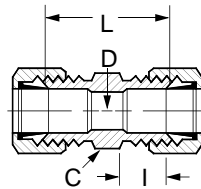
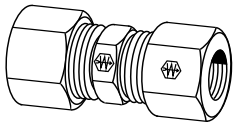

Assembly with long nut **1621x**

Tube O.D.	Catalog Number	Hex C	D	I	L
1/8	<b>621x2</b>	5/16	.094	.25	.66
3/16	<b>621x3</b>	3/8	.125	.28	.76
1/4	<b>621x4</b>	7/16	.188	.31	.79
5/16	<b>621x5</b>	1/2	.250	.34	.88
3/8	<b>621x6</b>	9/16	.312	.38	.97
1/2	<b>621x8</b>	11/16	.406	.44	1.10
5/8	<b>621x10</b>	13/16	.500	.50	1.25
3/4	<b>621x12*</b>	1	.562	.56	1.43

**Male Connector**

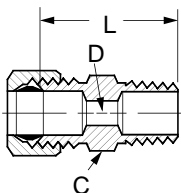

Assembly with long nut **1681x**  
\*Available only as assembly with long nut.

Tube O.D.	Male Pipe Thread	Catalog Number	Hex C	D	L
1/8	1/16	<b>681x2x1</b>	3/8	.094	.78
1/8	1/8	<b>681x2</b>	7/16	.094	.78
3/16	1/8	<b>681x3</b>	7/16	.125	.84
3/16	1/4	<b>681x3x4*</b>	9/16	.125	1.03
1/4	1/8	<b>681x4</b>	7/16	.188	.88
1/4	1/4	<b>681x4x4</b>	9/16	.188	1.06
5/16	1/8	<b>681x5</b>	1/2	.234	.91
5/16	1/4	<b>681x5x4</b>	9/16	.250	1.09
3/8	1/8	<b>681x6x2</b>	9/16	.250	.97
3/8	1/4	<b>681x6</b>	9/16	.312	1.17
3/8	3/8	<b>681x6x6</b>	11/16	.312	1.16
3/8	1/2	<b>681x6x8</b>	7/8	.312	1.34
1/2	1/4	<b>681x8x4</b>	11/16	.281	1.22
1/2	3/8	<b>681x8</b>	11/16	.406	1.22
1/2	1/2	<b>681x8x8</b>	7/8	.406	1.41
5/8	1/2	<b>681x10</b>	7/8	.500	1.50
3/4	1/2	<b>681x12*</b>	1	.562	1.62
3/4	3/4	<b>681x12x12*</b>	1	.562	1.62
1	1	<b>1681x16*</b>	1-3/8	.875	2.00

\*MTO - Made To Order

### Female Connector

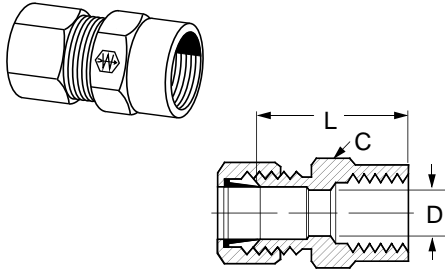

Assembly with long nut **1661x**

Tube O.D.	Fem. Pipe Thread	Catalog Number	Hex C	D	L
1/8	1/8	<b>661x2</b>	9/16	.094	.75
3/16	1/8	<b>661x3</b>	9/16	.125	.78
1/4	1/8	<b>661x4</b>	9/16	.188	.78
1/4	1/4	<b>661x4x4</b>	11/16	.188	1.03
5/16	1/8	<b>661x5</b>	9/16	.250	.81
5/16	1/4	<b>661x5x4♦</b>	11/16	.250	1.03
3/8	1/8	<b>661x6x2</b>	9/16	.312	.84
3/8	1/4	<b>661x6</b>	11/16	.312	1.06
1/2	3/8	<b>661x8</b>	13/16	.406	1.12
5/8	1/2	<b>661x10♦</b>	1	.500	1.38

### Male Ball Check Connector

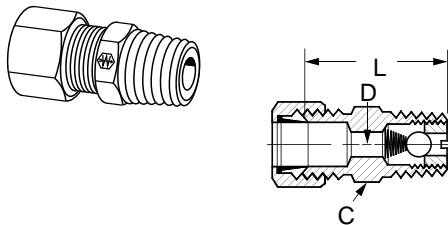

Assembly with long nut **1631x**. Min. pressure 3 psi. Ball and spring position may be reversed to change flow/check direction. Ballcheck valves are neither tested nor adjusted prior to sale.

Tube O.D.	Male Pipe Thread	Catalog Number	Hex C	D	L
3/16	1/8	<b>631x3♦</b>	7/16	.125	.84
1/4	1/8	<b>631x4</b>	7/16	.125	.88
5/16	1/8	<b>631x5♦</b>	1/2	.125	.91
3/8	1/4	<b>631x6</b>	9/16	.219	1.16

### Bulkhead Union

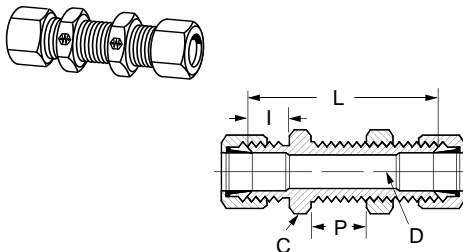

Assembly with long nut **1741x**  
For Bulkhead Nuts, ref. page 56.

Tube O.D.	Catalog Number	Hex C	D	I	L	Max. P
1/4	<b>741x4</b>	9/16	.188	.33	1.58	.52
5/16	<b>741x5♦</b>	5/8	.250	.34	1.69	.55
3/8	<b>741x6♦</b>	11/16	.312	.38	1.77	.55
1/2	<b>741x8♦</b>	13/16	.406	.44	1.94	.52

### Union Elbow

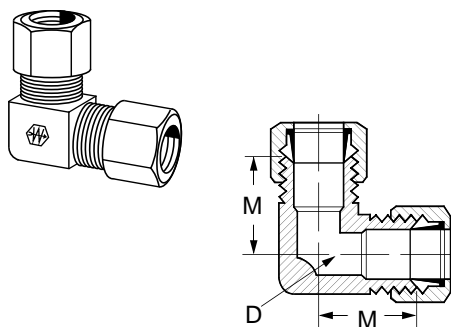

Assembly with long nut **1651x**

Tube O.D.	Catalog Number	D	M
3/16	<b>651x3♦</b>	.125	.59
1/4	<b>651x4</b>	.188	.60
5/16	<b>651x5♦</b>	.250	.62
3/8	<b>651x6</b>	.312	.73
1/2	<b>651x8♦</b>	.406	.94

♦MTO - Made To Order

**Male Elbow**

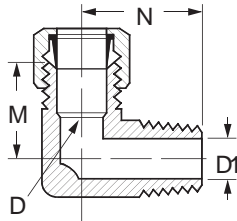
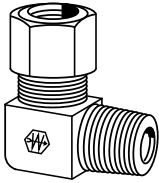

Assembly with long nut **1691x**.

\*Available only as assembly with long nut.

Tube O.D.	Male Pipe Thread	Catalog Number	D	D1	M	N
1/8	1/16	<b>691x2x1</b>	.109	.125	.54	.66
1/8	1/8	<b>691x2</b>	.094	.219	.60	.67
3/16	1/8	<b>691x3</b>	.125	.188	.62	.69
1/4	1/8	<b>691x4</b>	.188	.219	.62	.75
1/4	1/4	<b>691x4x4</b>	.188	.219	.62	.75
5/16	1/8	<b>691x5</b>	.250	.250	.62	.75
5/16	1/4	<b>691x5x4</b>	.250	.312	.69	.84
3/8	1/8	<b>691x6x2</b>	.312	.234	.69	.69
3/8	1/4	<b>691x6</b>	.312	.344	.75	.94
3/8	3/8	<b>691x6x6</b>	.312	.438	.84	.94
3/8	1/2	<b>691x6x8</b>	.312	.531	1.06	1.12
1/2	1/4	<b>691x8x4</b>	.406	.312	.84	.94
1/2	3/8	<b>691x8</b>	.406	.406	.94	1.12
1/2	1/2	<b>691x8x8</b>	.406	.531	.94	1.31
5/8	1/2	<b>691x10</b>	.500	.562	1.06	1.31
3/4	1/2	<b>691x12♦</b>	.562	.562	1.19	1.50
3/4	3/4	<b>691x12x12♦</b>	.562	.562	1.19	1.31
1	1	<b>1691x16*</b>	.875	.938	1.31	1.62

**Female Elbow**

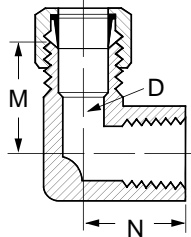
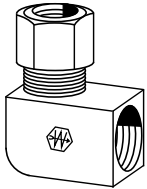

Assembly with long nut **1701x**

Tube O.D.	Fem. Pipe Thread	Catalog Number	D	M	N
3/16	1/8	<b>701x3</b>	.125	.69	.56
1/4	1/8	<b>701x4</b>	.188	.69	.56
5/16	1/8	<b>701x5♦</b>	.250	.69	.56
3/8	1/4	<b>701x6♦</b>	.312	.81	.75
1/2	3/8	<b>701x8♦</b>	.406	1.00	.88
5/8	1/2	<b>701x10♦</b>	.500	1.06	1.00

**Union Tee**

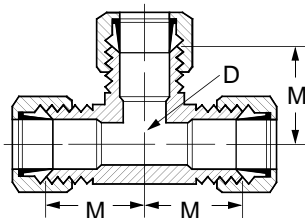
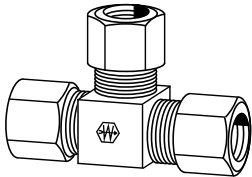

Assembly with long nut **1641x**

Tube O.D.	Catalog Number	D	M
3/16	<b>641x3</b>	.125	.60
1/4	<b>641x4</b>	.188	.62
5/16	<b>641x5</b>	.250	.60
3/8	<b>641x6</b>	.312	.73
1/2	<b>641x8</b>	.406	.94

♦MTO - Made To Order

### Male Run Tee

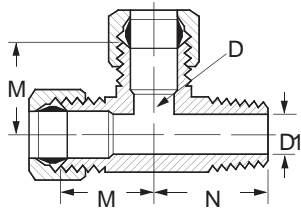
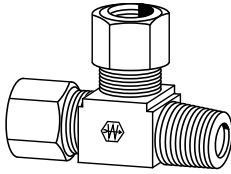

Assembly with long nut [1711x](#)

Tube O.D.	Male Pipe Thread	Catalog Number	D	D1 Opt.	M	N
3/16	1/8	<a href="#">711x3</a>	.125	.219	.62	.69
1/4	1/8	<a href="#">711x4</a>	.188	.219	.62	.75
1/4	1/4	<a href="#">711x4x4x4♦</a>	.188	.281	.66	.80
5/16	1/8	<a href="#">711x5♦</a>	.250	.219	.62	.75
3/8	1/4	<a href="#">711x6</a>	.312	.344	.75	.94
1/2	3/8	<a href="#">711x8♦</a>	.406	.406	.94	1.12

### Male Branch Tee

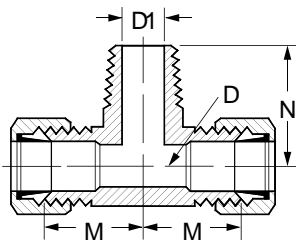
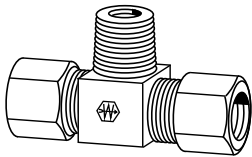

Assembly with long nut [1721x](#)

Tube O.D.	Male Pipe Thread	Catalog Number	D	D1	M	N
3/16	1/8	<a href="#">721x3♦</a>	.125	.219	.62	.69
1/4	1/8	<a href="#">721x4</a>	.188	.219	.62	.75
1/4	1/4	<a href="#">721x4x4x4</a>	.188	.281	.78	.85
5/16	1/8	<a href="#">721x5♦</a>	.250	.219	.62	.75
3/8	1/4	<a href="#">721x6</a>	.312	.344	.75	.94
1/2	3/8	<a href="#">721x8</a>	.406	.406	.94	1.12

### Adapter Tee (Female to Male Pipe Run)

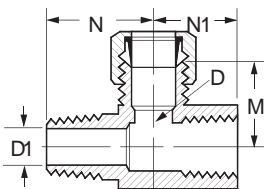
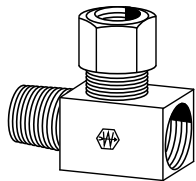

Assembly with long nut [1761x](#)

Tube O.D.	M&F Pipe Thread	Catalog Number	D	D1	M	N	N1
3/16	1/8	<a href="#">761x3♦</a>	.125	.219	.59	.56	.44
1/4	1/8	<a href="#">761x4♦</a>	.188	.219	.59	.63	.47

♦MTO - Made To Order

⚠ Refer to safety information regarding proper selection of tubing and tube fittings on page 1.

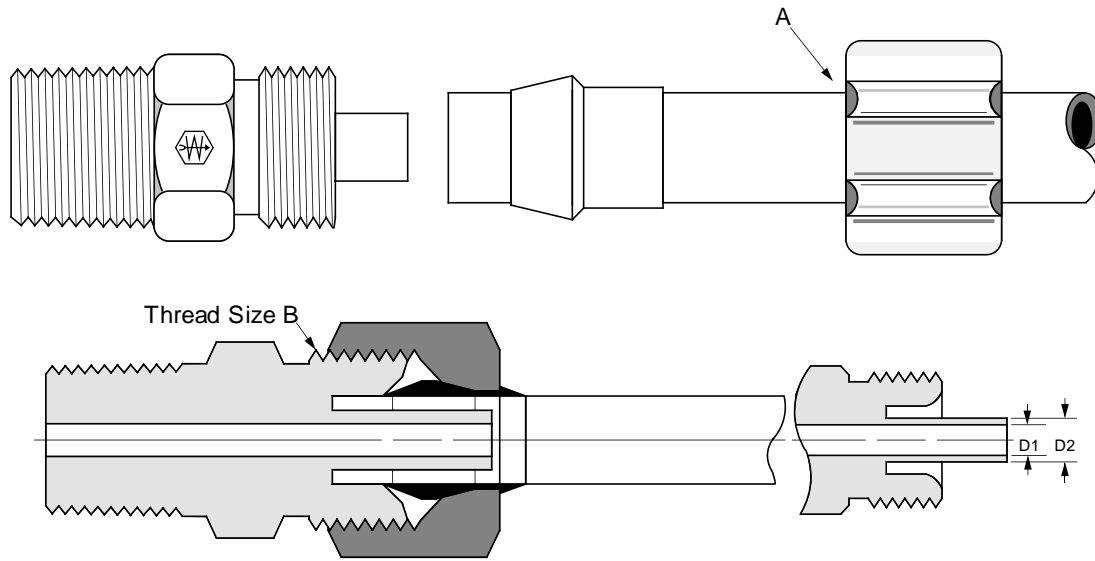

Size	x2	x3	x46	x4	x5	x6	x8
Tube O.D.	1/8	3/16	1/4	1/4	5/16	3/8	1/2
Thread Size-B	5/16-24	3/8-24	3/8-24	3/8-24	7/16-24	1/2-24	11/16-20
Flow Dia. (D1)	.094*	.125*	.078	.125	.141	.203	.312
Support Dia. (D2)	-	-	.120	.166	.180	.245	.370

\*No tube support in assembly – Flow Diameter for body only.

• **Typical Application**

Pneumatic instrumentation circuits, lubricant and cooling lines.

• **Pressure**

Working pressure up to 500 psi with a 4:1 safety factor depending on tube size. When using plastic tubing, use the working pressure for type used.

• **Vibration**

Excellent resistance.

• **Temperature Range**

-65°F to +250°F (-53°C to +121°C) with brass sleeve and metal tubing. When using compatible plastic tubing do not exceed the tubing temperature range. (Refer to tubing temperature range.)

• **Material**

CA360 Brass body, plastic sleeve.

• **Used With**

Aluminum, copper and hard plastic tubing requires brass sleeve.

• **Used With (Continued)**

Weatherhead PT200 and PT240 plastic tubing use plastic sleeve. Not recommended for steel tubing. See page 28-32 for material compatibility and pages 33-34 for plastic tubing.

• **Advantages**

No flaring of tubing required. Easy installation, captive sleeve, pre-assembled for installation and can be reassembled.

• **Conformance**

An exclusive item with Weatherhead. User approvals only.

• **How to Order**

Order 1/4" O.D. tubing with .040 wall, use suffix x4. Example: 1262x4. When .062 wall is desired, use suffix x46. Example: 1262x46.

Ordered as complete assemblies (body, nuts and sleeves) by catalog number. Nuts, sleeves and nut/sleeve assemblies can be ordered separately by catalog number.

**NOTE:** 1/8" and 3/16" tube O.D.

assemblies are supplied with brass sleeves and no inserts.

• **NOTE**

Refer to current price list for availability of cataloged items. Quotations and delivery of non-stock items supplied on request. Configurations and dimensions subject to change without notice.

• **Assembly Instructions**

1. Cut tubing to desired length.
2. Slide nut/sleeve assembly on tube. Threaded end "A" of nut must face toward fitting.
3. Bottom tubing into fitting.
4. **Plastic sleeve** - tighten nut, hand tight.  
**Brass sleeve** - tighten nut, hand tight, then additional 3/4 turn.

**Label Set:** **FS-2100** (adhesive)  
**CL-498** (non-adhesive)

### Cap

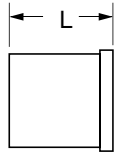

Tube O.D.	Catalog Number	L	Material
1/4	<a href="#">1229x4P♦</a>	.475	Plastic
3/8	<a href="#">1229x6P♦</a>	.490	Plastic

### Plastic Sleeve

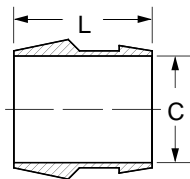
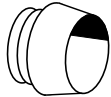

Tube O.D.	Catalog Number	C	L
1/4	<a href="#">1260x4</a>	.259	.34
5/16	<a href="#">1260x5</a>	.321	.39
3/8	<a href="#">1260x6</a>	.384	.41
1/2	<a href="#">1260x8</a>	.509	.44

### Brass Sleeve

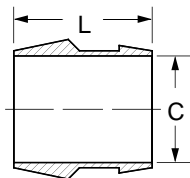

**NOTE:** 1/8" and 3/16" sleeve configurations vary from style illustrated

Tube O.D.	Catalog Number	C	L
1/4	<a href="#">1260x2B♦</a>	.130	.34
3/16	<a href="#">1260x3B♦</a>	.192	.30
1/4	<a href="#">1260x4B♦</a>	.263	.31
5/16	<a href="#">1260x5B♦</a>	.320	.36
3/8	<a href="#">1260x6B♦</a>	.384	.38
1/2	<a href="#">1260x8B♦</a>	.510	.41

### Brass Nut

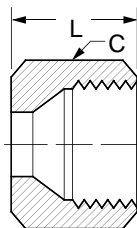

**NOTE:** 1/8" and 3/16" Nuts are flat Hex type

Tube O.D.	Catalog Number	Dia. C	L
1/8	<a href="#">1261x2</a>	3/8	.38
3/16	<a href="#">1261x3</a>	7/16	.38
1/4	<a href="#">1261x4</a>	7/16	.34
5/16	<a href="#">1261x5♦</a>	1/2	.34
3/8	<a href="#">1261x6</a>	9/16	.38
1/2	<a href="#">1261x8♦</a>	13/16	.44

♦MTO - Made To Order

**Brass Nut/Plastic Sleeve Assembly**

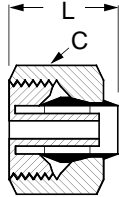
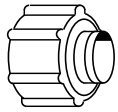

Tube O.D.	Catalog Number	Dia. C	L
1/4	1261x4A	7/16	.43
5/16	1261x5A♦	1/2	.45
3/8	1261x6A	9/16	.49
1/2	1261x8A♦	13/16	.46

**Brass Nut/Brass Sleeve Assembly**

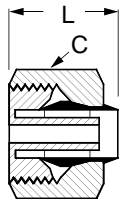
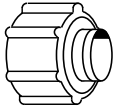

Tube O.D.	Catalog Number	Dia. C	L
1/8	1261x2B♦	7/16	.45
3/16	1261x3B♦	1/2	.41
1/4	1261x4B♦	9/16	.43
3/8	1261x6B♦	13/16	.49

NOTE: 1/8" and 3/16" Nuts are flat Hex type

**Brass Bulkhead Nut**

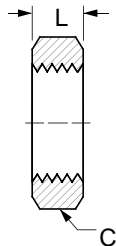

Tube O.D.	Catalog Number	Hex C	L
1/8	1202x2♦	5/16	.25
1/4	1202x4♦	9/16	.19
5/16	1202x5♦	5/8	.19
3/8	1202x6♦	11/16	.19
1/2	1202x8♦	7/8	.19

For use with 1274x Bulkhead Unions, ref. pages 63 & 64.

**Union**

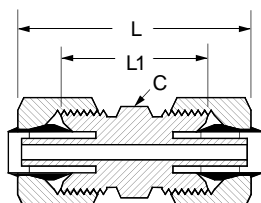
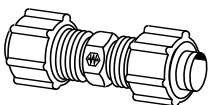

Tube O.D.	Catalog Number	Hex C	L	L1
1/8	1262x2♦	5/16	—	.66
3/16	1262x3♦	3/8	—	.75
1/4	1262x4	3/8	1.00	.69
1/4	1262x46♦	3/8	1.00	.69
1/4x3/8	1262x4x6♦	1/2	1.03	.70
5/16	1262x5♦	7/16	1.00	.69
3/8	1262x6	1/2	1.03	.72
1/2	1262x8♦	11/16	1.28	.84



### Selfalign® to Polyline® Union

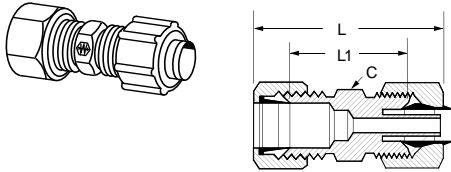

**NOTE:** Selfalign® Tube - Brass Sleeve, Polyline® Tube - Plastic Sleeve. For replacement Selfalign® Nuts and Sleeve, ref. page 55.

Tube O.D.	Catalog Number	Hex C	L	L1
1/4	1262x4x4S♦	7/16	1.36	.69
3/8	1262x6S♦	9/16	1.52	.72

### Male Connector

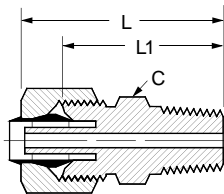
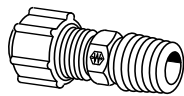

\*10-32 Straight Thread

Tube O.D.	Male Pipe Thread	Catalog Number	Hex C	L	L1
1/8	1/16	1268x2x1♦	3/8	—	.84
1/8	1/8	1268x2♦	7/16	—	.78
3/16	1/8	1268x3♦	7/16	—	.84
1/4	10-32*	1268x4A♦	3/8	.90	.59
1/4	1/16	1268x4x1	7/16	.97	.81
1/4	1/8	1268x4	7/16	.97	.81
1/4	1/8	1268x46♦	7/16	.97	.81
1/4	1/4	1268x4x4	9/16	1.15	1.00
1/4	1/4	1268x46x4♦	9/16	1.16	1.00
1/4	3/8	1268x4x6♦	11/16	1.18	1.03
5/16	1/8	1268x5♦	7/16	.97	.81
5/16	1/4	1268x5x4♦	9/16	1.16	1.00
3/8	1/8	1268x6x2	1/2	1.00	.84
3/8	1/4	1268x6	9/16	1.19	1.03
3/8	3/8	1268x6x6	11/16	1.19	1.03
1/2	1/4	1268x8x4♦	11/16	1.31	1.09
1/2	3/8	1268x8	11/16	1.31	1.09
1/2	1/2	1268x8x8♦	11/16	1.62	1.03

### Female Connector

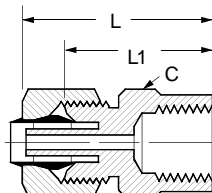
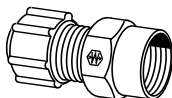

Tube O.D.	Fem. Pipe Thread	Catalog Number	Hex C	L	L1
1/8	1/8	1266x2	9/16	—	.75
3/16	1/8	1266x3♦	9/16	—	.78
1/4	1/8	1266x4	1/2	.87	.72
1/4	1/8	1266x46♦	1/2	.87	.72
1/4	1/4	1266x4x4	5/8	1.09	.93
1/4	1/4	1266x46x4♦	5/8	1.09	.94
5/16	1/8	1266x5♦	1/2	.88	.72
5/16	1/4	1266x5x4♦	5/8	1.06	.90
3/8	1/8	1266x6x2♦	1/2	.91	.75
3/8	1/4	1266x6	5/8	1.09	.94
1/2	3/8	1266x8♦	13/16	1.21	1.00

### Bulkhead Union

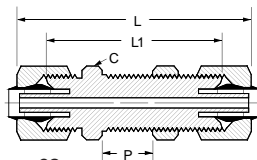
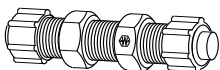

For Bulkhead Nuts, ref. page 62.

Tube O.D.	Catalog Number	Hex C	L	L1	Max. P
1/8	1274x2♦	5/16	—	1.45	.38
1/4	1274x4♦	9/16	1.56	1.25	.38
5/16	1274x5♦	5/8	1.56	1.25	.38
3/8	1274x6♦	11/16	1.68	1.38	.47
1/2	1274x8♦	7/8	2.09	1.66	.63

♦MTO - Made To Order

**Selfalign® to Polyline®  
Bulkhead Union**

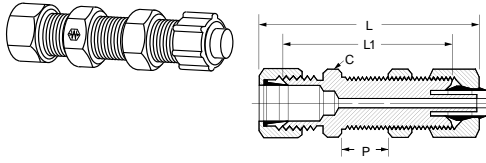

Selfalign® Sleeve Brass, Polyline® Sleeve Plastic.  
For replacement Selfalign® Sleeve, ref. page 55. For  
Bulkhead Nuts, ref. page 62.

Tube O.D.	Catalog Number	Hex C	L	L1	Max. P
1/4	1274x4x4S♦	9/16	1.81	1.47	.38

**Union Elbow**

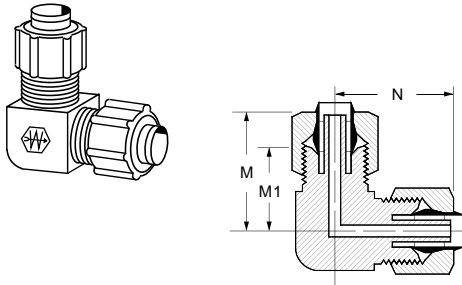

Tube O.D.	Catalog Number	M	M1	N
1/4	1265x46♦	.75	.594	.75

**Male Elbow**

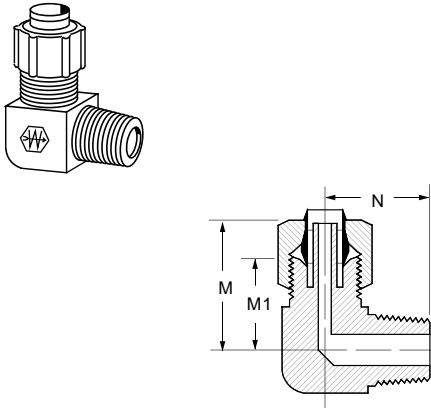

Tube O.D.	Male Pipe Thread	Catalog Number	M	M1	N
1/8	1/16	1269x2x1♦	—	.54	.66
1/8	1/8	1269x2♦	—	.59	.66
3/16	1/8	1269x3♦	—	.59	.66
1/4	1/16	1269x4x1	.75	.59	.72
1/4	1/8	1269x4	.75	.59	.72
1/4	1/8	1269x46♦	.75	.59	.72
1/4	1/4	1269x4x4	.81	.66	.94
1/4	1/4	1269x4x4L♦	.81	.66	1.38
1/4	1/4	1269x46x4♦	.81	.66	.94
1/4	3/8	1269x4x6	.84	.69	1.08
5/16	1/8	1269x5♦	.75	.59	.72
5/16	1/4	1269x5x4♦	.81	.66	.91
3/8	1/8	1269x6x2	.88	.66	.75
3/8	1/4	1269x6	.87	.72	1.00
3/8	3/8	1269x6x6	.87	.72	1.08
1/2	1/4	1269x8x4♦	1.00	.78	1.12
1/2	3/8	1269x8♦	1.06	.84	1.12

“L” Suffix designates long leg elbow

**Female Elbow**

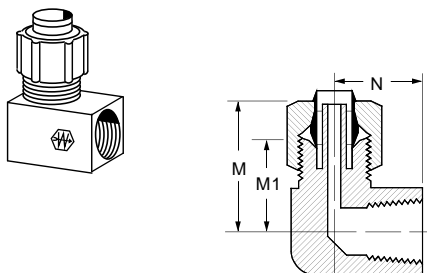

Tube O.D.	Fem. Pipe Thread	Catalog Number	M	M1	N
1/8	1/8	1270x2♦	—	.62	.69
1/4	1/8	1270x4	.87	.66	.56
1/4	1/8	1270x46♦	.87	.66	.56
1/4	1/4	1270x4x4	.96	.75	.69
5/16	1/8	1270x5♦	.92	.66	.56
3/8	1/4	1270x6♦	.86	.75	.69
1/2	3/8	1270x8♦	1.19	.91	.94

### Union Tee

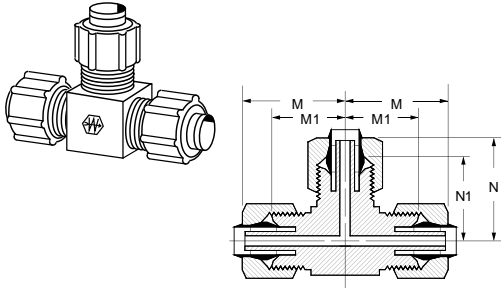

Tube O.D.	Catalog Number	M	M1	N	N1
1/4	1264x4	.75	.59	.75	.59
1/4	1264x46♦	.75	.59	.75	.59
5/16	1264x5♦	.75	.59	.75	.59
3/8x3/8x1/4	1264x6x6x4♦	.88	.72	.81	.65
3/8	1264x6	.87	.72	.87	.72
1/2	1264x8♦	1.06	.84	1.06	.84

### Male Run Tee

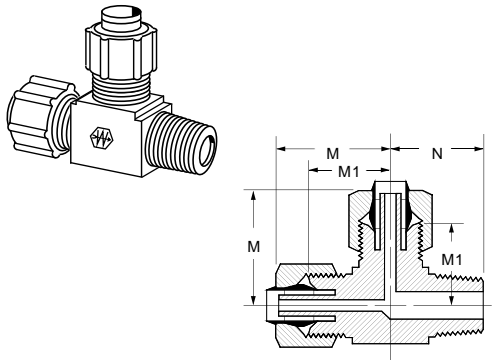

Tube O.D.	Male Pipe Thread	Catalog Number	M	M1	N
1/4	1/8	1271x4	.75	.59	.72
1/4	1/8	1271x46♦	.75	.59	.72
1/4	1/4	1271x4x4x4♦	.81	.66	.94
5/16	1/8	1271x5♦	.75	.59	.72
3/8	1/4	1271x6♦	.87	.72	1.00
1/2	3/8	1271x8♦	1.06	.84	1.12

### Male Branch Tee

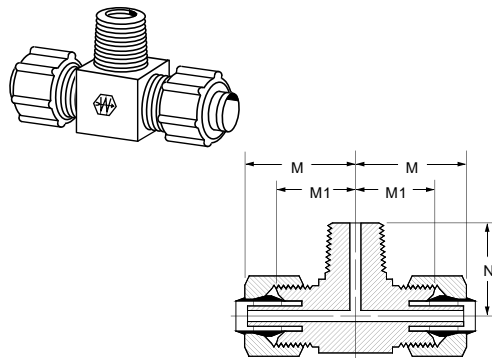

Tube O.D.	Male Pipe Thread	Catalog Number	M	M1	N
3/16	1/8	1272x3♦	—	.62	.69
1/4	1/8	1272x4♦	.75	.59	.72
1/4	1/8	1272x46♦	.75	.59	.72
1/4	1/4	1272x4x4x4♦	.81	.66	.94
5/16	1/8	1272x5♦	.75	.59	.72
3/8	1/4	1272x6♦	.87	.72	1.00
1/2	3/8	1272x8♦	1.06	.84	1.12

### Female Branch Tee

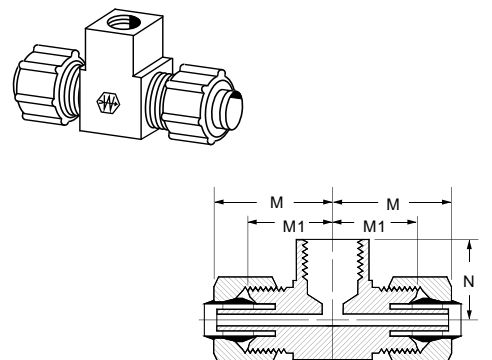

Tube O.D.	Fem. Pipe Thread	Catalog Number	M	M1	N
1/4	1/8	1277x4♦	.81	.65	.56
1/4	1/4	1277x4x4x4♦	.91	.75	.69
1/4	3/8	1277x4x4x6♦	.94	.78	.75

♦MTO - Made To Order

BRASS

 Refer to safety information regarding proper selection of tubing and tube fittings on page 1.

## Push > Connect®

## Push > Connect® Metric

## Push > Connect® Flow Controls

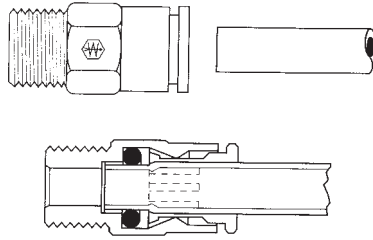
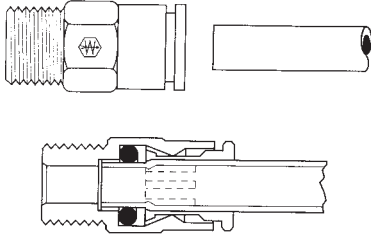

Nominal Size	2	4	5MM	6	8
Thread					
MM			M5 x .8		
BSPT	1/8 (2PT)	1/4 (4PT)		3/8 (6PT)	1/2 (8PT)
BSPP	1/8 (2PP)	1/4 (4PP)		3/8 (6PP)	1/2

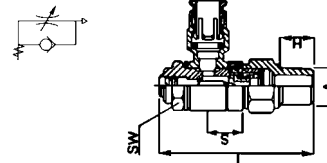
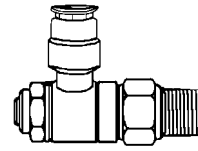

- **Typical Application:** Compressed air, pneumatic instrumentation, circuit, lubricant and cooling lines.
- **Pressure:** Up to 250 psi depending on tube size.
- **Sealing Method:** O-Ring of Buna-N Construction. (Viton available on request by special order.)
- **Temperature Range:** When using compatible plastic tubing do not exceed the tubing temperature range (Refer to tubing temperature range).
- **Material:** Brass, Nickel Plated.
- **Vacuum:** Fittings rated at 29.5 inches of mercury vacuum.
- **Used With:** PT230 and TP160 nylon, and PT240 Polyethylene tubing. See page 28-32 for material compatibility and pages 33-34 for plastic tubing.
- **Advantages:** Ease of assembly. No tools required, reusability of fittings and the time savings of assembly and disassembly.
- **Hex Dimensions:** All hexes are in inches.
- **How to Order:** Individually by catalog number.
- **NOTE:** Refer to current price list for availability of cataloged items. Quotations and delivery of non-stock items supplied on request. Configurations and dimensions subject to change without notice.
- **Assembly Instructions**
  1. To connect, simply push the tubing into the fitting.
  2. To disconnect, depress the collet ring with two fingers and withdraw.

**Label Set:** CL-499 (non-adhesive)

See Push > Connect® Fittings on pages 67-71.

- **Typical Application:** Compressed air, pneumatic instrumentation, circuit, lubricant and cooling lines.
- **Pressure:** Up to 250 psi depending on tube size.
- **Sealing Method:** O-Ring of Buna-N Construction. (Viton available on request by special order.)
- **Temperature Range:** -40°F to 200°F (-40°C to 93°C).
- **Material:** Brass, Nickel Plated.
- **Used With:** MTP160 nylon tubing. See page 28-32 for material compatibility and page 34 for plastic tubing.
- **Advantages:** Ease of assembly. No tools required, reusability of fittings and the time savings of assembly and disassembly.
- **Hex Dimensions:** All hexes are metric.
- **How to Order:** Individually by catalog number.
- **NOTE:** Refer to current price list for availability of cataloged items. Quotations and delivery of non-stock items supplied on request. Configurations and dimensions subject to change without notice.
- **Assembly Instructions**
  1. To connect, simply push the tubing into the fitting.
  2. To disconnect, depress the collet ring with two fingers and withdraw.

### SUFFIX CHART

MM - Metric Screw Thread
MMS - Metric Screw Thread Swivel
MRP - Metric Red Plug
PP - British Parallel Plug
PPS - British Parallel Pipe Swivel
PT - British Tapered Pipe
PTS - British Tapered Pipe Swivel

See Push > Connect® Fittings on pages 72-75.

- **Typical Application:** Compressed air, pneumatic instrumentation, circuit, lubricant and cooling lines. Also excellent for assembly equipment and cylinder control.
- **Pressure:** Up to 250 psi depending on tube size.
- **Sealing Method:** O-Ring of Buna-N Construction. (Viton available on request by special order.)
- **Temperature Range:** 0°F to +160°F (-17.8°C to +71°C)
- **Material:** Brass, Nickel Plated.
- **Used With:** PT230 and TP160 nylon, and PT240 Polyethylene tubing. See page 28-32 for material compatibility and pages 33 & 34 for plastic tubing.
- **Advantages:** Ease of assembly. No tools required, reusability of fittings and the time savings of assembly and disassembly. These flow controls have a simple design, but offer excellent ability to control the speed of a cylinder or motor.
- **Hex Dimensions:** All hexes are in inches.
- **How to Order:** Individually by catalog number.
- **NOTE:** Refer to current price list for availability of cataloged items. Quotations and delivery of non-stock items supplied on request. Configurations and dimensions subject to change without notice.
- **Assembly Instructions**
  1. To connect, simply push the tubing into the fitting.
  2. To disconnect, depress the collet ring with two fingers and withdraw.

See Push > Connect® Fittings on pages 76 & 77.

### Cartridge

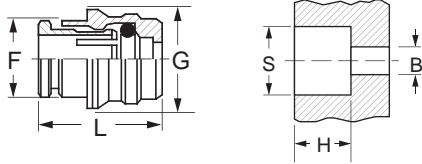
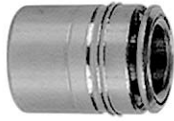

Cartridge body is not Nickel-plated.

Tube O.D.	Catalog Number	F	G	L	S	H	B
1/8	<a href="#">1161x2</a>	.34	.35	.59	.344	.433	.14
5/32	<a href="#">1161x2.5</a>	.34	.35	.57	.344	.433	.14
1/4	<a href="#">1161x4</a>	.46	.48	.65	.470	.472	.16
5/16	<a href="#">1161x5</a>	.54	.56	.67	.549	.551	.25
3/8	<a href="#">1161x6</a>	.62	.64	.79	.627	.590	.32
1/2	<a href="#">1161x8</a>	.74	.76	.83	.746	.629	.42

### Plug (Plastic)

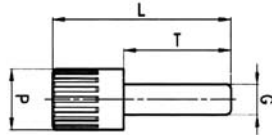

Tube O.D.	Catalog Number	L	P	T
1/8	<a href="#">1129x2</a>	1.04	.24	.65
5/32	<a href="#">1129x2.5</a>	1.04	.24	.65
1/4	<a href="#">1129x4</a>	1.10	.32	.71
5/16	<a href="#">1129x5</a>	1.20	.39	.81
3/8	<a href="#">1129x6</a>	1.38	.47	.91
1/2	<a href="#">1129x8</a>	1.42	.55	.94

### Double Union



NOTE: Joins Push>Connect® Fittings.

Tube O.D.	Catalog Number	L
1/8	<a href="#">1105x2</a>	1.28
5/32	<a href="#">1105x2.5</a>	1.28
1/4	<a href="#">1105x4</a>	1.40
5/16	<a href="#">1105x5</a>	1.59
3/8	<a href="#">1105x6</a>	1.81
1/2	<a href="#">1105x8</a>	1.89

### Reducer



A

B

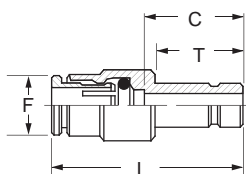

Tube O.D. A	Tube O.D. B	Catalog Number	C	F	L	T
1/8	1/4	<a href="#">1109x2x4</a>	.79	.39	1.38	.71
5/32	1/4	<a href="#">1109x2.5x4</a>	.79	.39	1.34	.71
1/4	3/8	<a href="#">1109x4x6</a>	.86	.51	1.50	.91
1/4	1/2	<a href="#">1109x4x8</a>	.86	.51	1.50	.91
3/8	1/2	<a href="#">1109x6x8</a>	1.00	.67	1.80	.94

**Stem Adapter**

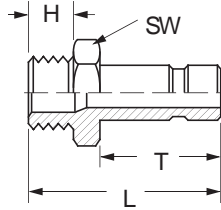

Tube O.D.	Male Pipe Thread	Catalog Number	H	T	L	SW (mm)
1/8	1/8	1180x2	.37	.65	1.20	12
1/8	1/4	1180x2x4	.51	.65	1.36	14
5/32	1/8	1180x2.5	.37	.65	1.20	12
5/32	1/4	1180x2.5x4	.51	.65	1.36	14
1/4	1/8	1180x4	.37	.71	1.26	12
1/4	1/4	1180x4x4	.51	.71	1.42	14
5/16	1/8	1180x5	.37	.81	1.36	12
5/16	1/4	1180x5x4	.51	.81	1.34	14
3/8	1/4	1180x6	.51	.91	1.61	17
3/8	3/8	1180x6x6	.51	.91	1.61	19
1/2	3/8	1180x8	.51	.94	1.65	19
1/2	1/2	1180x8x8	.71	.94	1.87	22

**Union**

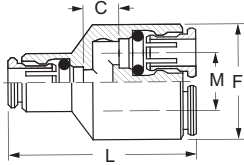

Tube O.D.	Catalog Number	F	G	L	N
1/8	1162x2	.35	.39	1.26	.59
5/32	1162x2.5	.35	.39	1.18	.55
1/4	1162x4	.46	.47	1.40	.64
5/16	1162x5	.54	.55	1.23	.69
3/8	1162x6	.64	.67	1.67	.79
1/2	1162x8	.72	.75	1.75	.83

NOTE: Joins tubing.

**Bulkhead Union**

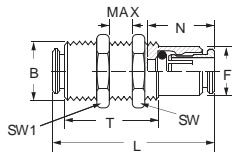

Tube O.D.	Catalog Number	B	F	L	N	MAX	SW (mm)	SW1 (mm)	T
1/8	1174x2	M10x1	.35	1.26	.59	.35	14	14	.83
5/32	1174x2.5	M10x1	.35	1.18	.55	.32	14	14	.79
1/4	1174x4	M14x1	.49	1.40	.64	.37	17	17	.83
5/16	1174x5	M16x1	.54	1.50	.69	.41	19	19	.83
3/8	1174x6	M18x1	.64	1.67	.77	.47	22	22	.93
1/2	1174x8	M20x1	.72	1.75	.83	.53	24	24	.98

**Union "Y"**

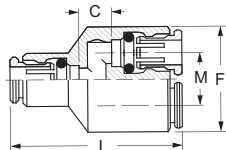

Tube O.D.	Catalog Number	C	F	L	M
1/8	1107x2	.24	.83	1.42	.39
5/32	1107x2.5	.24	.83	1.34	.39
1/4	1107x4	.24	.96	1.52	.49

NOTE: UNF thread seal with nylon washer included.

### Swivel Male "Y"

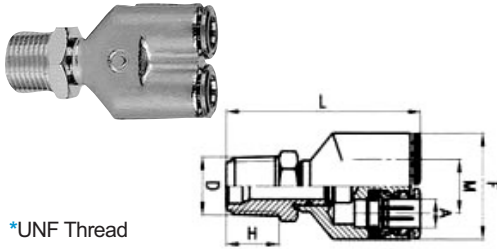

\*UNF Thread

Tube O.D.	Male Pipe Thread	Catalog Number	F	M	L
1/8	10-32*	1108x2A	.83	.39	1.12
1/8	1/8	1108x2	.83	.39	1.32
5/32	1/8	1108x2.5	.83	.39	1.29
1/4	1/8	1108x4	.96	.49	1.40

### Male Connector

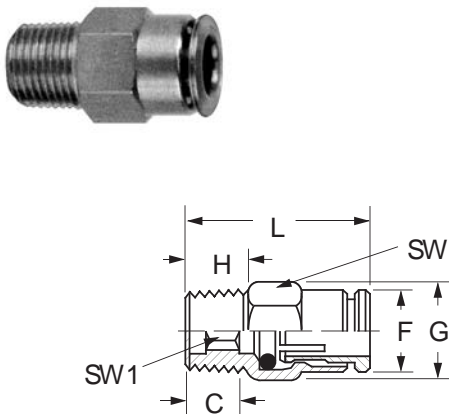

\*UNF Thread

Allen wrench use permits close quarter installation not possible with a standard wrench.

Tube O.D.	Male Pipe Thread	Catalog Number	C	F	G	H	L	SW (mm)	SW1 (mm)
1/8	10-32*	1168x2A	.26	.35	.41	.18	.85	9	2
1/8	1/8	1168x2	.26	.35	.55	.37	.85	12	2
1/8	1/4	1168x2x4	.39	.35	.63	.51	.98	14	2
5/32	10-32*	1168x2.5A	.26	.35	.41	.18	.81	9	2
5/32	1/8	1168x2.5	.26	.35	.55	.37	.81	12	2.5
5/32	1/4	1168x2.5x4	.39	.35	.63	.51	.94	14	2.5
1/4	10-32*	1168x4A	.27	.46	.55	.18	.91	12	2
1/4	1/8	1168x4	.35	.46	.55	.37	.98	12	4
1/4	1/4	1168x4x4	.44	.46	.63	.51	1.08	14	4
1/4	3/8	1168x4x6	.46	.46	.87	.51	1.10	19	4
5/16	1/8	1168x5	.45	.54	.63	.37	1.14	14	5
5/16	1/4	1168x5x4	.45	.54	.63	.51	1.14	14	6
5/16	3/8	1168x5x6	.45	.54	.87	.51	1.14	19	6
3/8	1/8	1168x6x2	.59	.64	.78	.51	1.38	17	7
3/8	1/4	1168x6	.59	.64	.78	.51	1.38	17	7
3/8	3/8	1168x6x6	.39	.64	.87	.51	1.18	19	7
3/8	1/2	1168x6x8	.47	.64	1.00	.71	1.26	22	7
1/2	3/8	1168x8	.53	.72	.87	.51	1.36	19	10
1/2	1/2	1168x8x8	.53	.72	1.00	.71	1.36	22	10

### Female Connector

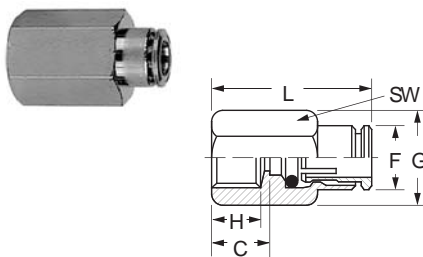

Tube O.D.	Fem. Pipe Thread	Catalog Number	C	F	G	H	L	SW (mm)
1/8	1/8	1166x2	.41	.35	.64	.34	1.00	14
1/8	1/4	1166x2x4	.55	.35	.78	.47	1.14	17
5/32	1/8	1166x2.5	.41	.35	.64	.34	.96	14
5/32	1/4	1166x2.5x4	.55	.35	.78	.47	1.10	17
1/4	1/8	1166x4	.43	.46	.64	.34	1.06	14
1/4	1/4	1166x4x4	.56	.46	.78	.47	1.20	17
3/8	1/4	1166x6	.57	.64	.78	.47	1.36	17
3/8	3/8	1166x6x6	.59	.64	1.00	.49	1.38	22

### Union Elbow

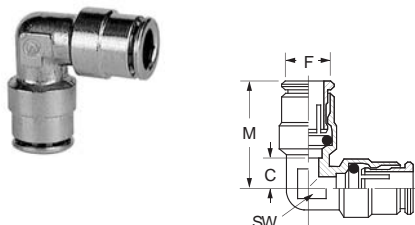

Tube O.D.	Catalog Number	C	F	M	SW (mm)
1/8	1165x2	.24	.39	.83	9
5/32	1165x2.5	.24	.39	.79	9
1/4	1165x4	.27	.50	.91	10
5/16	1165x5	.30	.59	.98	12
3/8	1165x6	.34	.69	1.12	14
1/2	1165x8	.39	.77	1.22	17

NOTE: UNF Thread seals with nylon washer, included.

**Swivel Male Elbow**

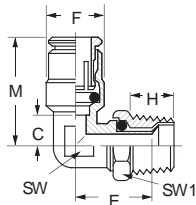

\*UNF Thread

NOTE: Swivel for installation purposes only.

Tube O.D.	Male Pipe Thread	Catalog Number	C	E	F	H	M	SW (mm)	SW1 (mm)
1/8	10-32*	1169x2AS	.24	.53	.39	.18	.83	9	8
1/8	1/8	1169x2S	.24	.71	.39	.37	.83	9	12
1/8	1/4	1169x2x4S	.24	.87	.39	.51	.83	9	14
5/32	10-32*	1169x2.5AS	.24	.53	.39	.18	.79	9	8
5/32	1/8	1169x2.5S	.24	.71	.39	.37	.79	9	12
5/32	1/4	1169x2.5x4S	.24	.87	.39	.51	.83	9	14
1/4	1/8	1169x4S	.27	.73	.50	.37	.91	10	12
1/4	1/4	1169x4x4S	.27	.81	.50	.51	.91	10	14
1/4	3/8	1169x4x6S	.29	.87	.50	.51	.93	12	19
5/16	1/8	1169x5S	.30	.77	.59	.37	.98	12	12
5/16	1/4	1169x5x4S	.30	.85	.59	.51	.98	12	14
5/16	3/8	1169x5x6S	.30	.87	.59	.51	.98	12	19
3/8	1/8	1169x6x2S	.34	.75	.64	.20	1.10	14	14
3/8	1/4	1169x6S	.34	.89	.69	.51	1.12	14	14
3/8	3/8	1169x6x6S	.34	.91	.69	.51	1.12	14	19
3/8	1/2	1169x6x8S	.34	1.04	.69	.71	1.12	14	22
1/2	1/4	1169x8x4S	.39	.95	.77	.51	1.22	17	14
1/2	3/8	1169x8S	.39	.95	.77	.51	1.22	17	19
1/2	1/2	1169x8x8S	.39	1.12	.77	.71	1.22	17	22

**Male Elbow**

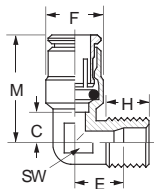

Tube O.D.	Male Pipe Thread	Catalog Number	C	E	F	H	M	SW (mm)
1/4	1/8	1169x4	.27	.53	.50	.38	.91	10
1/4	1/4	1169x4x4	.27	.59	.50	.51	.91	10
3/8	1/4	1169x6	.34	.69	.69	.51	1.12	14
3/8	3/8	1169x6x6	.34	.69	.69	.51	1.12	14

**Union Tee**

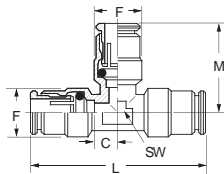

Tube O.D.	Catalog Number	C	F	L	M	SW (mm)
1/8	1164x2	.24	.39	1.65	.83	9
5/32	1164x2.5	.24	.39	1.57	.79	9
1/4	1164x4	.27	.50	1.81	.91	10
5/16	1164x5	.30	.59	1.97	.98	12
3/8	1164x6	.34	.69	2.24	1.12	14
1/2	1164x8	.39	.77	2.44	1.22	19

**Male Run Tee Swivel**

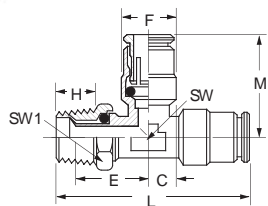

\*UNF Thread

NOTE: Swivel for installation purposes only.

Tube O.D.	Male Pipe Thread	Catalog Number	E	F	H	L	M	SW (mm)	SW1 (mm)
1/8	10-32*	1171x2AS	.53	.39	.18	1.53	.83	9	8
1/8	1/8	1171x2S	.59	.35	.20	1.59	.80	9	12
5/32	10-32*	1171x2.5AS	.53	.39	.18	1.50	.79	9	8
5/32	1/8	1171x2.5S	.59	.35	.20	1.57	.79	9	12
5/32	1/4	1171x2.5x4S	.63	.35	.26	1.67	.79	9	14
1/4	1/8	1171x4S	.61	.46	.20	1.69	.89	10	12
1/4	1/4	1171x4x4S	.65	.46	.26	1.79	.89	10	14
1/4	3/8	1171x4x6S	.65	.46	.29	1.83	.89	12	19
3/8	1/4	1171x6S	.77	.64	.26	2.17	1.10	14	14
3/8	3/8	1171x6x6S	.77	.64	.29	2.26	1.10	14	19
3/8	1/2	1171x6x8S	.79	.64	.34	2.22	1.10	14	22
1/2	1/4	1171x8x4S	.81	.72	.26	2.26	1.20	17	13
1/2	3/8	1171x8S	.81	.72	.29	2.30	1.20	17	19
1/2	1/2	1171x8x8S	.83	.72	.34	2.36	1.20	17	22

NOTE: UNF Thread seals with nylon washer, included.



### Male Branch Tee Swivel

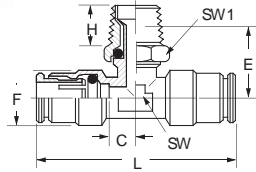

\*UNF Thread

NOTE: Swivel for installation purposes only.

Tube O.D.	Male Pipe Thread	Catalog Number	C	E	F	H	L	SW (mm)	SW1 (mm)
1/8	10-32*	1172x2AS	.24	.53	.39	.18	1.61	.35	.32
1/8	1/8	1172x2S	.24	.59	.35	.20	1.57	.35	.47
5/32	10-32*	1172x2.5AS	.24	.53	.39	.18	1.57	.35	.32
5/32	1/8	1172x2.5S	.24	.59	.35	.20	1.57	.35	.47
5/32	1/4	1172x2.5x4S	.24	.63	.35	.26	1.57	.35	.55
1/4	1/8	1172x4S	.28	.60	.46	.20	1.77	.39	.47
1/4	1/4	1172x4x4S	.28	.65	.46	.26	1.77	.39	.55
1/4	3/8	1172x4x6S	.28	.65	.46	.29	1.77	.47	.75
3/8	1/4	1172x6S	.34	.77	.64	.26	2.20	.55	.55
3/8	3/8	1172x6x6S	.34	.77	.64	.29	2.20	.55	.75
3/8	1/2	1172x6x8S	.34	.79	.64	.34	2.20	.55	.87
1/2	1/4	1172x8x4S	.39	.80	.72	.26	2.40	.67	.55
1/2	3/8	1172x8S	.39	.80	.72	.29	2.40	.67	.75
1/2	1/2	1172x8x8S	.39	.83	.72	.34	2.40	.67	.87

### Stud Manifolds

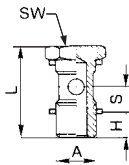

\*UNF Thread

Male Pipe Thread A	Catalog Number	H	L	S (mm)	SW (mm)
10-32*	1184x1xA	.16	.71	.18	.32
1/8	1184x1x2	.24	1.06	.34	.55
1/4	1184x1x4	.35	1.16	.34	.67
3/8	1184x1x6	.35	1.18	.34	.75

### Stud Manifolds

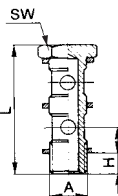

Male Pipe Thread A	Catalog Number	H	L	SW (mm)
1/8	1185x2x2	.24	1.69	.55
1/4	1185x2x4	.32	1.79	.67
3/8	1185x2x6	.35	1.81	.75

### Banjo

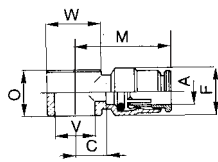

Tube O.D.	Catalog Number	V	C	F	M	O	V	W
5/32	1181x2.5A	10-32	.20	.35	.75	.35	.20	.35
1/8	1181x2x2	1/8	.32	.39	.89	.57	.39	.55
5/32	1181x2.5x2	1/8	.32	.39	.89	.57	.39	.55
1/4	1181x4x2	1/8	.35	.50	.98	.57	.39	.55
1/4	1181x4x4	1/4	.43	.50	1.06	.57	.52	.71
3/8	1181x6x4	1/4	.39	.69	1.18	.57	.52	.71
3/8	1181x6x6	3/8	.45	.69	1.24	.57	.66	.83

### Double Banjo

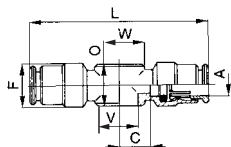

Tube O.D.	Catalog Number	V	C	F	M	O	V	W
5/32	1182x2.5A	5/16	.20	.35	1.50	.35	.21	.35
1/4	1182x4x2	1/8	.32	.51	1.89	.57	.39	.55
1/4	1182x4x4	1/4	.39	.51	2.09	.57	.52	.71
3/8	1182x6x4	1/4	.39	.69	2.32	.57	.52	.71
3/8	1182x6x6	3/8	.45	.69	2.44	.57	.66	.83

### Female Banjo

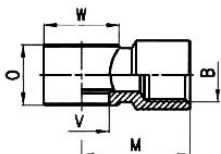

\*UNF Thread

Female Pipe Thread B	Catalog Number	V	O	M	W
10-32*	1183xAxA	10-32	.35	.41	.35
1/8	1183x2x2	1/8	.57	.83	.55
1/4	1183x4x4	1/4	.57	1.02	.71
3/8	1183x6x6	3/8	.57	1.12	.83

NOTE: UNF Thread seals with nylon washer, included.

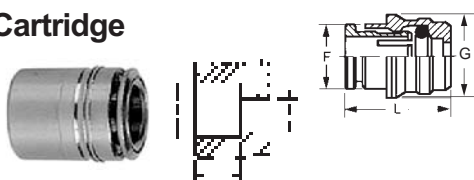
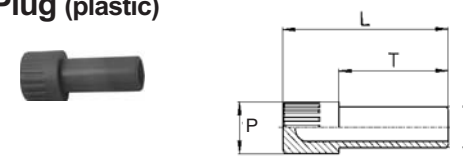
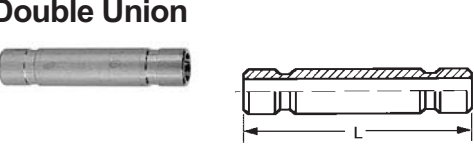
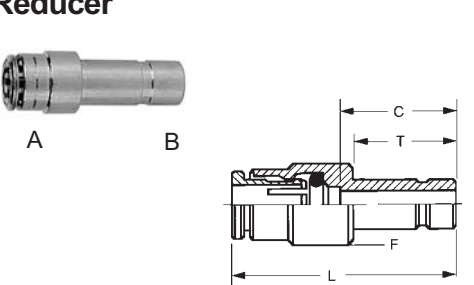
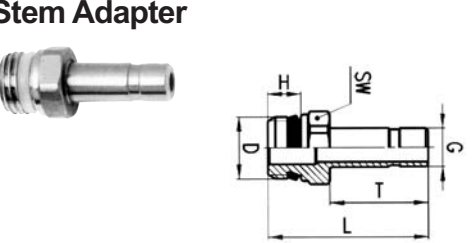
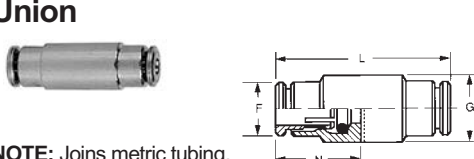
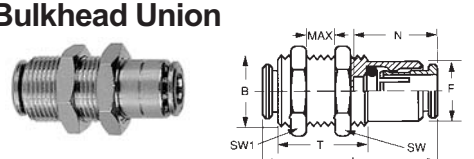
<p><b>Cartridge</b></p> 	<table border="1"> <thead> <tr> <th>Tube O.D. (mm)</th> <th>Catalog Number</th> <th>F</th> <th>G</th> <th>L</th> <th>S</th> <th>H</th> <th>B</th> </tr> </thead> <tbody> <tr> <td>4</td> <td>1161x4M</td> <td>8.6</td> <td>9.0</td> <td>14.5</td> <td>8.75</td> <td>11.0</td> <td>3.5</td> </tr> <tr> <td>5</td> <td>1161x5M</td> <td>9.6</td> <td>10.0</td> <td>15.5</td> <td>9.75</td> <td>11.5</td> <td>3.5</td> </tr> <tr> <td>6</td> <td>1161x6M</td> <td>11.8</td> <td>12.2</td> <td>16.5</td> <td>11.95</td> <td>12.0</td> <td>4.0</td> </tr> <tr> <td>8</td> <td>1161x8M</td> <td>13.8</td> <td>14.2</td> <td>18.0</td> <td>13.95</td> <td>14.0</td> <td>6.0</td> </tr> <tr> <td>10</td> <td>1161x10M</td> <td>15.8</td> <td>16.2</td> <td>20.5</td> <td>15.95</td> <td>15.0</td> <td>8.0</td> </tr> </tbody> </table>	Tube O.D. (mm)	Catalog Number	F	G	L	S	H	B	4	1161x4M	8.6	9.0	14.5	8.75	11.0	3.5	5	1161x5M	9.6	10.0	15.5	9.75	11.5	3.5	6	1161x6M	11.8	12.2	16.5	11.95	12.0	4.0	8	1161x8M	13.8	14.2	18.0	13.95	14.0	6.0	10	1161x10M	15.8	16.2	20.5	15.95	15.0	8.0																																				
Tube O.D. (mm)	Catalog Number	F	G	L	S	H	B																																																																														
4	1161x4M	8.6	9.0	14.5	8.75	11.0	3.5																																																																														
5	1161x5M	9.6	10.0	15.5	9.75	11.5	3.5																																																																														
6	1161x6M	11.8	12.2	16.5	11.95	12.0	4.0																																																																														
8	1161x8M	13.8	14.2	18.0	13.95	14.0	6.0																																																																														
10	1161x10M	15.8	16.2	20.5	15.95	15.0	8.0																																																																														
<p><b>Plug (plastic)</b></p> 	<table border="1"> <thead> <tr> <th>Tube O.D. (mm)</th> <th>Catalog Number</th> <th>L</th> <th>P</th> <th>T</th> </tr> </thead> <tbody> <tr> <td>4</td> <td>1129x4MRP</td> <td>25.0</td> <td>8</td> <td>16.0</td> </tr> <tr> <td>5</td> <td>1129x5MRP</td> <td>25.5</td> <td>8</td> <td>16.5</td> </tr> <tr> <td>6</td> <td>1129x6MRP</td> <td>26.5</td> <td>8</td> <td>17.5</td> </tr> <tr> <td>8</td> <td>1129x8MRP</td> <td>29.5</td> <td>12</td> <td>19.5</td> </tr> <tr> <td>10</td> <td>1129x10MRP</td> <td>32.0</td> <td>12</td> <td>19.5</td> </tr> <tr> <td>12</td> <td>1129x12MRP</td> <td>35.5</td> <td>16</td> <td>23.5</td> </tr> </tbody> </table>	Tube O.D. (mm)	Catalog Number	L	P	T	4	1129x4MRP	25.0	8	16.0	5	1129x5MRP	25.5	8	16.5	6	1129x6MRP	26.5	8	17.5	8	1129x8MRP	29.5	12	19.5	10	1129x10MRP	32.0	12	19.5	12	1129x12MRP	35.5	16	23.5																																																	
Tube O.D. (mm)	Catalog Number	L	P	T																																																																																	
4	1129x4MRP	25.0	8	16.0																																																																																	
5	1129x5MRP	25.5	8	16.5																																																																																	
6	1129x6MRP	26.5	8	17.5																																																																																	
8	1129x8MRP	29.5	12	19.5																																																																																	
10	1129x10MRP	32.0	12	19.5																																																																																	
12	1129x12MRP	35.5	16	23.5																																																																																	
<p><b>Double Union</b></p>  <p>NOTE: Joins Metric Push&gt;Connect® fittings.</p>	<table border="1"> <thead> <tr> <th>Tube O.D. (mm)</th> <th>Catalog Number</th> <th>L</th> </tr> </thead> <tbody> <tr> <td>4</td> <td>1105x4M</td> <td>32.5</td> </tr> <tr> <td>5</td> <td>1105x5M</td> <td>35.0</td> </tr> <tr> <td>6</td> <td>1105x6M</td> <td>35.5</td> </tr> <tr> <td>8</td> <td>1105x8M</td> <td>40.5</td> </tr> <tr> <td>10</td> <td>1105x10M</td> <td>46.0</td> </tr> <tr> <td>12</td> <td>1105x12M</td> <td>48.0</td> </tr> </tbody> </table>	Tube O.D. (mm)	Catalog Number	L	4	1105x4M	32.5	5	1105x5M	35.0	6	1105x6M	35.5	8	1105x8M	40.5	10	1105x10M	46.0	12	1105x12M	48.0																																																															
Tube O.D. (mm)	Catalog Number	L																																																																																			
4	1105x4M	32.5																																																																																			
5	1105x5M	35.0																																																																																			
6	1105x6M	35.5																																																																																			
8	1105x8M	40.5																																																																																			
10	1105x10M	46.0																																																																																			
12	1105x12M	48.0																																																																																			
<p><b>Reducer</b></p> 	<table border="1"> <thead> <tr> <th>Tube O.D. A (mm)</th> <th>Tube O.D. B (mm)</th> <th>Catalog Number</th> <th>C</th> <th>F</th> <th>L</th> <th>T</th> </tr> </thead> <tbody> <tr> <td>4</td> <td>5</td> <td>1109x4Mx5M</td> <td>20.0</td> <td>10</td> <td>34.0</td> <td>18.0</td> </tr> <tr> <td>4</td> <td>6</td> <td>1109x4Mx6M</td> <td>20.0</td> <td>10</td> <td>34.0</td> <td>18.0</td> </tr> <tr> <td>4</td> <td>8</td> <td>1109x4Mx8M</td> <td>19.0</td> <td>10</td> <td>33.0</td> <td>20.5</td> </tr> <tr> <td>5</td> <td>6</td> <td>1109x5Mx6M</td> <td>20.0</td> <td>11</td> <td>35.0</td> <td>18.0</td> </tr> <tr> <td>5</td> <td>8</td> <td>1109x5Mx8M</td> <td>19.0</td> <td>11</td> <td>34.0</td> <td>20.5</td> </tr> <tr> <td>6</td> <td>8</td> <td>1109x6Mx8M</td> <td>22.5</td> <td>13</td> <td>38.5</td> <td>20.5</td> </tr> <tr> <td>6</td> <td>10</td> <td>1109x6Mx10M</td> <td>21.0</td> <td>13</td> <td>36.5</td> <td>23.0</td> </tr> <tr> <td>6</td> <td>12</td> <td>1109x6Mx12M</td> <td>22.0</td> <td>13</td> <td>37.5</td> <td>24.0</td> </tr> <tr> <td>8</td> <td>10</td> <td>1109x8Mx10M</td> <td>25.0</td> <td>14</td> <td>42.5</td> <td>23.0</td> </tr> <tr> <td>8</td> <td>12</td> <td>1109x8Mx12M</td> <td>22.5</td> <td>14</td> <td>40.0</td> <td>24.0</td> </tr> <tr> <td>10</td> <td>12</td> <td>1109x10Mx12M</td> <td>25.5</td> <td>17</td> <td>45.5</td> <td>24.0</td> </tr> </tbody> </table>	Tube O.D. A (mm)	Tube O.D. B (mm)	Catalog Number	C	F	L	T	4	5	1109x4Mx5M	20.0	10	34.0	18.0	4	6	1109x4Mx6M	20.0	10	34.0	18.0	4	8	1109x4Mx8M	19.0	10	33.0	20.5	5	6	1109x5Mx6M	20.0	11	35.0	18.0	5	8	1109x5Mx8M	19.0	11	34.0	20.5	6	8	1109x6Mx8M	22.5	13	38.5	20.5	6	10	1109x6Mx10M	21.0	13	36.5	23.0	6	12	1109x6Mx12M	22.0	13	37.5	24.0	8	10	1109x8Mx10M	25.0	14	42.5	23.0	8	12	1109x8Mx12M	22.5	14	40.0	24.0	10	12	1109x10Mx12M	25.5	17	45.5	24.0
Tube O.D. A (mm)	Tube O.D. B (mm)	Catalog Number	C	F	L	T																																																																															
4	5	1109x4Mx5M	20.0	10	34.0	18.0																																																																															
4	6	1109x4Mx6M	20.0	10	34.0	18.0																																																																															
4	8	1109x4Mx8M	19.0	10	33.0	20.5																																																																															
5	6	1109x5Mx6M	20.0	11	35.0	18.0																																																																															
5	8	1109x5Mx8M	19.0	11	34.0	20.5																																																																															
6	8	1109x6Mx8M	22.5	13	38.5	20.5																																																																															
6	10	1109x6Mx10M	21.0	13	36.5	23.0																																																																															
6	12	1109x6Mx12M	22.0	13	37.5	24.0																																																																															
8	10	1109x8Mx10M	25.0	14	42.5	23.0																																																																															
8	12	1109x8Mx12M	22.5	14	40.0	24.0																																																																															
10	12	1109x10Mx12M	25.5	17	45.5	24.0																																																																															
<p><b>Stem Adapter</b></p> 	<table border="1"> <thead> <tr> <th>Tube O.D. (mm)</th> <th>Thd. Size BSPP</th> <th>Catalog Number</th> <th>H</th> <th>T</th> <th>L</th> <th>SW (mm)</th> </tr> </thead> <tbody> <tr> <td>4</td> <td>1/8</td> <td>1180x4Mx2PP</td> <td>5.5</td> <td>16.5</td> <td>27.8</td> <td>12</td> </tr> <tr> <td>5</td> <td>1/8</td> <td>1180x5Mx2PP</td> <td>5.5</td> <td>18.0</td> <td>29.3</td> <td>12</td> </tr> <tr> <td>6</td> <td>1/8</td> <td>1180x6Mx2PP</td> <td>5.5</td> <td>18.0</td> <td>29.3</td> <td>12</td> </tr> <tr> <td>6</td> <td>1/4</td> <td>1180x6Mx4PP</td> <td>7.0</td> <td>18.0</td> <td>31.0</td> <td>14</td> </tr> <tr> <td>8</td> <td>1/8</td> <td>1180x8Mx2PP</td> <td>5.5</td> <td>20.5</td> <td>31.8</td> <td>12</td> </tr> <tr> <td>8</td> <td>1/4</td> <td>1180x8Mx4PP</td> <td>7.0</td> <td>20.5</td> <td>33.5</td> <td>14</td> </tr> <tr> <td>10</td> <td>1/4</td> <td>1180x10Mx4PP</td> <td>7.0</td> <td>23.0</td> <td>36.0</td> <td>14</td> </tr> <tr> <td>10</td> <td>3/8</td> <td>1180x10Mx6PP</td> <td>8.0</td> <td>23.0</td> <td>37.3</td> <td>19</td> </tr> <tr> <td>12</td> <td>3/8</td> <td>1180x12Mx6PP</td> <td>8.0</td> <td>24.0</td> <td>38.3</td> <td>19</td> </tr> </tbody> </table>	Tube O.D. (mm)	Thd. Size BSPP	Catalog Number	H	T	L	SW (mm)	4	1/8	1180x4Mx2PP	5.5	16.5	27.8	12	5	1/8	1180x5Mx2PP	5.5	18.0	29.3	12	6	1/8	1180x6Mx2PP	5.5	18.0	29.3	12	6	1/4	1180x6Mx4PP	7.0	18.0	31.0	14	8	1/8	1180x8Mx2PP	5.5	20.5	31.8	12	8	1/4	1180x8Mx4PP	7.0	20.5	33.5	14	10	1/4	1180x10Mx4PP	7.0	23.0	36.0	14	10	3/8	1180x10Mx6PP	8.0	23.0	37.3	19	12	3/8	1180x12Mx6PP	8.0	24.0	38.3	19														
Tube O.D. (mm)	Thd. Size BSPP	Catalog Number	H	T	L	SW (mm)																																																																															
4	1/8	1180x4Mx2PP	5.5	16.5	27.8	12																																																																															
5	1/8	1180x5Mx2PP	5.5	18.0	29.3	12																																																																															
6	1/8	1180x6Mx2PP	5.5	18.0	29.3	12																																																																															
6	1/4	1180x6Mx4PP	7.0	18.0	31.0	14																																																																															
8	1/8	1180x8Mx2PP	5.5	20.5	31.8	12																																																																															
8	1/4	1180x8Mx4PP	7.0	20.5	33.5	14																																																																															
10	1/4	1180x10Mx4PP	7.0	23.0	36.0	14																																																																															
10	3/8	1180x10Mx6PP	8.0	23.0	37.3	19																																																																															
12	3/8	1180x12Mx6PP	8.0	24.0	38.3	19																																																																															
<p><b>Union</b></p>  <p>NOTE: Joins metric tubing.</p>	<table border="1"> <thead> <tr> <th>Tube O.D. (mm)</th> <th>Catalog Number</th> <th>F</th> <th>G</th> <th>L</th> <th>N</th> </tr> </thead> <tbody> <tr> <td>4</td> <td>1162x4M</td> <td>8.8</td> <td>10</td> <td>30.0</td> <td>14.0</td> </tr> <tr> <td>5</td> <td>1162x5M</td> <td>9.8</td> <td>11</td> <td>33.0</td> <td>15.0</td> </tr> <tr> <td>6</td> <td>1162x6M</td> <td>11.7</td> <td>12</td> <td>34.0</td> <td>15.5</td> </tr> <tr> <td>8</td> <td>1162x8M</td> <td>13.7</td> <td>14</td> <td>38.0</td> <td>17.5</td> </tr> <tr> <td>10</td> <td>1162x10M</td> <td>16.3</td> <td>17</td> <td>41.5</td> <td>19.5</td> </tr> <tr> <td>12</td> <td>1162x12M</td> <td>18.3</td> <td>19</td> <td>44.5</td> <td>21.0</td> </tr> </tbody> </table>	Tube O.D. (mm)	Catalog Number	F	G	L	N	4	1162x4M	8.8	10	30.0	14.0	5	1162x5M	9.8	11	33.0	15.0	6	1162x6M	11.7	12	34.0	15.5	8	1162x8M	13.7	14	38.0	17.5	10	1162x10M	16.3	17	41.5	19.5	12	1162x12M	18.3	19	44.5	21.0																																										
Tube O.D. (mm)	Catalog Number	F	G	L	N																																																																																
4	1162x4M	8.8	10	30.0	14.0																																																																																
5	1162x5M	9.8	11	33.0	15.0																																																																																
6	1162x6M	11.7	12	34.0	15.5																																																																																
8	1162x8M	13.7	14	38.0	17.5																																																																																
10	1162x10M	16.3	17	41.5	19.5																																																																																
12	1162x12M	18.3	19	44.5	21.0																																																																																
<p><b>Bulkhead Union</b></p> 	<table border="1"> <thead> <tr> <th>Tube O.D. (mm)</th> <th>Catalog Number</th> <th>B</th> <th>F</th> <th>L</th> <th>N</th> <th>MAX</th> <th>SW</th> <th>SW1</th> <th>T</th> </tr> </thead> <tbody> <tr> <td>4</td> <td>1174x4M</td> <td>M10x1</td> <td>8.6</td> <td>30.0</td> <td>14.0</td> <td>10.5</td> <td>14</td> <td>14</td> <td>20.0</td> </tr> <tr> <td>5</td> <td>1174x5M</td> <td>M12x1</td> <td>9.8</td> <td>33.0</td> <td>14.5</td> <td>10.5</td> <td>17</td> <td>17</td> <td>20.0</td> </tr> <tr> <td>6</td> <td>1174x6M</td> <td>M14x1</td> <td>12.5</td> <td>34.0</td> <td>15.5</td> <td>10.5</td> <td>17</td> <td>17</td> <td>20.0</td> </tr> <tr> <td>8</td> <td>1174x8M</td> <td>M16x1</td> <td>14.5</td> <td>38.0</td> <td>17.5</td> <td>11.5</td> <td>19</td> <td>19</td> <td>21.0</td> </tr> <tr> <td>10</td> <td>1174x10M</td> <td>M18x1</td> <td>16.3</td> <td>42.5</td> <td>20.0</td> <td>13.0</td> <td>22</td> <td>22</td> <td>23.5</td> </tr> <tr> <td>12</td> <td>1174x12M</td> <td>M20x1</td> <td>18.3</td> <td>44.5</td> <td>21.0</td> <td>14.5</td> <td>24</td> <td>24</td> <td>25.0</td> </tr> </tbody> </table>	Tube O.D. (mm)	Catalog Number	B	F	L	N	MAX	SW	SW1	T	4	1174x4M	M10x1	8.6	30.0	14.0	10.5	14	14	20.0	5	1174x5M	M12x1	9.8	33.0	14.5	10.5	17	17	20.0	6	1174x6M	M14x1	12.5	34.0	15.5	10.5	17	17	20.0	8	1174x8M	M16x1	14.5	38.0	17.5	11.5	19	19	21.0	10	1174x10M	M18x1	16.3	42.5	20.0	13.0	22	22	23.5	12	1174x12M	M20x1	18.3	44.5	21.0	14.5	24	24	25.0														
Tube O.D. (mm)	Catalog Number	B	F	L	N	MAX	SW	SW1	T																																																																												
4	1174x4M	M10x1	8.6	30.0	14.0	10.5	14	14	20.0																																																																												
5	1174x5M	M12x1	9.8	33.0	14.5	10.5	17	17	20.0																																																																												
6	1174x6M	M14x1	12.5	34.0	15.5	10.5	17	17	20.0																																																																												
8	1174x8M	M16x1	14.5	38.0	17.5	11.5	19	19	21.0																																																																												
10	1174x10M	M18x1	16.3	42.5	20.0	13.0	22	22	23.5																																																																												
12	1174x12M	M20x1	18.3	44.5	21.0	14.5	24	24	25.0																																																																												

# Push > Connect<sup>®</sup> Metric

**Brass Fittings**

## Union "Y"

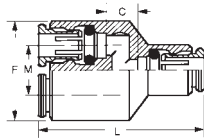

Tube O.D. (mm)	Catalog Number	F	C	L	M
4	<a href="#">1107x4M</a>	18.0	6.0	33.0	10.0
6	<a href="#">1107x6M</a>	24.5	7.0	39.0	12.5
8	<a href="#">1107x8M</a>	29.5	9.0	44.0	14.5
10	<a href="#">1107x10M</a>	33.5	15.5	53.5	16.0

## Male "Y"

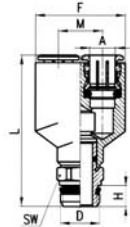

Tube O.D. (mm)	Thread Size BSP	Catalog Number	F	H	M	L
4	1/8	<a href="#">1108x4Mx2PT</a>	18.0	5.5	10.0	38.0
4	M5*	<a href="#">1108x4Mx5MM</a>	18.0	—	10.0	27.0
6	1/8	<a href="#">1108x6Mx2PT</a>	24.5	5.5	12.5	41.5
6	M5*	<a href="#">1108x6Mx5MM</a>	24.5	—	12.5	31.0
8	1/8	<a href="#">1108x8Mx2PT</a>	29.5	5.5	14.5	48.5
8	1/4	<a href="#">1108x8Mx4PT</a>	29.5	7.0	14.5	50.0

\*M5 metric screw thread.

## Male Connector (Universal BSPT/BSP)

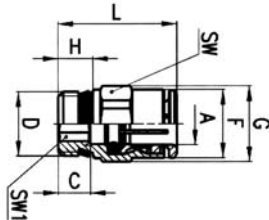

Tube O.D. (mm)	Thread Size BSP	Catalog Number	C	F	G	H	L	SW (mm)	SW1 (mm)
4	1/8	<a href="#">1168x4Mx2PT</a>	3.8	8.8	13.2	5.5	18.0	12	2.5
4	1/4	<a href="#">1168x4Mx4PT</a>	6.0	8.8	15.2	7.0	19.5	14	2.5
5	1/8	<a href="#">1168x5Mx2PT</a>	3.8	9.8	13.2	5.5	19.0	12	3.0
5	1/4	<a href="#">1168x5Mx4PT</a>	5.5	9.8	15.2	7.0	20.0	14	3.0
6	1/8	<a href="#">1168x6Mx2PT</a>	5.0	11.7	13.2	5.5	20.5	12	4.0
6	1/4	<a href="#">1168x6Mx4PT</a>	5.5	11.7	15.2	7.0	21.0	14	4.0
8	1/8	<a href="#">1168x8Mx2PT</a>	7.5	13.7	15.2	5.5	25.0	14	5.0
8	1/4	<a href="#">1168x8Mx4PT</a>	6.5	13.7	15.2	7.0	24.0	14	6.0
8	3/8	<a href="#">1168x8Mx6PT</a>	6.5	13.7	20.5	8.0	23.5	19	6.0
10	1/4	<a href="#">1168x10Mx4PT</a>	8.5	16.3	18.5	7.0	28.5	17	7.0
10	3/8	<a href="#">1168x10Mx6PT</a>	5.5	16.3	20.5	8.0	25.5	19	8.0
10	1/2	<a href="#">1168x10Mx8PT</a>	5.0	16.3	24.5	9.0	25.0	22	8.0
12	1/4	<a href="#">1168x12Mx4PT</a>	10.5	18.3	20.5	7.0	31.5	19	7.0
12	3/8	<a href="#">1168x12Mx6PT</a>	9.5	18.3	20.5	8.0	30.5	19	9.0
12	1/2	<a href="#">1168x12Mx8PT</a>	6.0	18.3	24.5	9.0	27.0	22	10.0

Allen wrench use permits close quarter installation not possible with a standard wrench.

## Male Connector (BSPP)

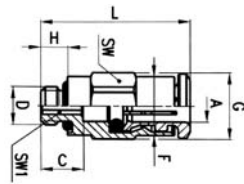

Tube O.D. (mm)	Thread Size BSPP	Catalog Number	C	F	G	H	L	SW (mm)	SW1 (mm)
4	M5*	<a href="#">1168x4Mx5MM</a>	5.5	7.8	8.8	3.5	19.5	8	2
5	M5*	<a href="#">1168x5Mx5MM</a>	5.5	8.8	9.9	3.5	20.5	9	2
6	M5*	<a href="#">1168x6Mx5MM</a>	5.5	11.7	13.2	3.5	21.5	12	2

\*M5 metric screw thread.

Allen wrench use permits close quarter installation not possible with a standard wrench.

## Female Connector (BSPP)

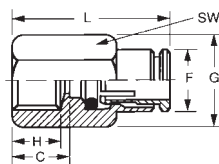
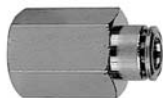

Tube O.D. (mm)	Thread Size BSPP	Catalog Number	C	F	G	H	L	SW (mm)
4	1/8	<a href="#">1166x4Mx2PP</a>	9.5	9.0	15.2	7.5	23.5	14
4	M5*	<a href="#">1166x4Mx5MM</a>	6.5	8.8	9.9	5.0	20.5	9
6	1/8	<a href="#">1166x6Mx2PP</a>	9.5	11.7	15.2	7.5	25.5	14
6	1/4	<a href="#">1166x6Mx4PP</a>	13.0	11.7	18.5	11.0	29.0	17
8	1/8	<a href="#">1166x8Mx2PP</a>	10.0	13.7	15.3	7.5	27.5	14
8	1/4	<a href="#">1166x8Mx4PP</a>	13.5	13.7	18.5	11.0	31.0	17
10	1/4	<a href="#">1166x10Mx4PP</a>	13.5	16.3	18.5	11.0	33.0	17

\*M5 is M profile thread.

NOTE: M5 has 0.8 mm thread pitch. M5 seals with nylon washer, included.

BRASS

**Union Elbow**

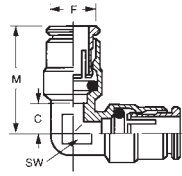

Tube O.D. (mm)	Catalog Number	C	F	M	SW (mm)
4	1165x4M	6.0	10.0	20	9
5	1165x5M	6.0	11.0	21	9
6	1165x6M	6.5	13.0	22	10
8	1165x8M	7.5	15.0	25	12
10	1165x10M	8.5	17.5	28	14
12	1165x12M	10.0	19.5	31	16

**Male Elbow (BSPT)**

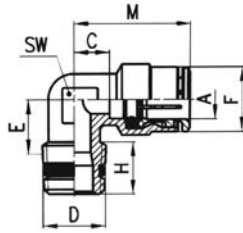

Tube O.D. (mm)	Thread Size BSPT	Catalog Number	C	F	H	M	SW (mm)
4	1/8	1169x4Mx2PT	6.0	10.0	7.5	20	9
4	1/4	1169x4Mx4PT	6.0	10.0	11.0	20	9
5	1/8	1169x5Mx2PT	6.0	11.0	7.5	21	9
5	1/4	1169x5Mx4PT	6.0	11.0	11.0	21	9
6	1/8	1169x6Mx2PT	6.5	12.7	8.5	22	10
6	1/4	1169x6Mx4PT	6.5	12.7	11.5	22	10
8	1/8	1169x8Mx2PT	7.5	15.0	8.5	25	12
8	1/4	1169x8Mx4PT	7.5	15.0	11.0	25	12
8	3/8	1169x8Mx6PT	7.5	15.0	11.5	25	12
10	1/4	1169x10Mx4PT	7.5	17.5	11.5	27	14
10	3/8	1169x10Mx6PT	7.5	17.5	11.5	27	14
12	1/4	1169x12Mx4PT	10.0	19.5	11.5	31	16
12	3/8	1169x12Mx6PT	10.0	19.5	11.5	31	16

**Male Elbow Swivel (Universal BSPT/BSPP)**

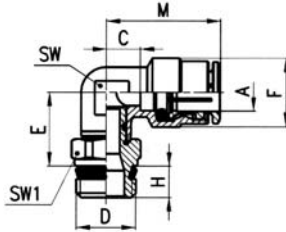

Tube O.D. (mm)	Thread Size BSPT	Catalog Number	C	E	F	H	M	SW (mm)	SW1 (mm)
4	1/8	1169x4Mx2PTS	6.0	14.5	10.0	5.5	20.0	9	12
4	1/4	1169x4Mx4PTS	6.0	14.5	10.0	7.0	20.0	9	14
5	1/8	1169x5Mx2PTS	6.0	14.5	11.0	5.5	21.0	9	12
5	1/4	1169x5Mx4PTS	6.0	14.5	11.0	7.0	21.0	9	14
6	1/8	1169x6Mx2PTS	6.5	15.0	12.7	5.5	22.0	10	12
6	1/4	1169x6Mx4PTS	6.5	15.0	12.7	7.0	22.5	10	14
8	1/8	1169x8Mx2PTS	7.5	16.0	15.0	5.5	25.5	12	12
8	1/4	1169x8Mx4PTS	7.5	16.0	15.0	7.0	25.0	12	14
8	3/8	1169x8Mx6PTS	7.5	16.5	15.0	8.0	25.0	12	19
10	1/4	1169x10Mx4PTS	8.5	18.5	17.5	7.0	28.5	14	14
10	3/8	1169x10Mx6PTS	8.5	19.0	17.5	8.0	28.5	14	19
10	1/2	1169x10Mx8PTS	8.5	19.5	17.5	9.0	28.5	14	22
12	1/4	1169x12Mx4PTS	10.0	20.0	19.5	7.0	31.0	16	17
12	3/8	1169x12Mx6PTS	10.0	20.0	19.5	8.0	31.0	16	19
12	1/2	1169x12Mx8PTS	10.0	20.5	19.5	9.0	31.0	16	22

NOTE: Swivel for installation purposes only.

**Male Elbow Swivel (BSPP)**

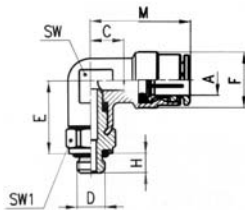

Tube O.D. (mm)	Thread Size BSPP	Catalog Number	C	E	F	H	M	SW (mm)	SW1 (mm)
4	M5*	1169x4Mx5MMS	6	13	10	3.5	20	9	8
5	M5*	1169x5Mx5MMS	6	13	11	3.5	21	9	8

NOTE: Swivel for installation purposes only.  
\*M5 metric screw thread.

**Union Tee**

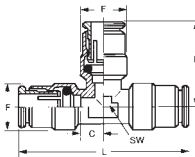

Tube O.D. (mm)	Catalog Number	C	F	L	M	SW (mm)
4	1164x4M	6.0	10.0	40	20.0	9
5	1164x5M	6.0	11.0	42	21.0	9
6	1164x6M	6.5	12.7	45	22.5	10
8	1164x8M	7.5	15.0	50	25.0	12
10	1164x10M	8.5	17.5	57	28.5	14
12	1164x12M	10.0	19.5	62	31.0	16

NOTE: M5 has 0.8 mm thread pitch. M5 seals with nylon washer, included.

### Male Run Tee Swivel (Universal BSPT/BSPP)

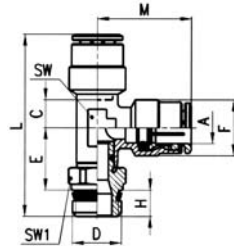

NOTE: Swivel for installation purposes only.

Tube O.D. (mm)	Thread Size BSP	Catalog Number	C	E	F	H	L	M	SW	SW1 (mm)
4	1/8	1171x4Mx2PTS	6.0	14.5	10.0	5.5	40.0	20.0	9	12
5	1/8	1171x5Mx2PTS	6.0	14.5	11.0	5.5	41.0	21.0	9	12
5	1/4	1171x5Mx4PTS	6.0	14.5	11.0	7.0	42.5	21.0	9	14
6	1/8	1171x6Mx2PTS	6.5	15.0	12.7	5.5	42.5	22.5	10	12
6	1/4	1171x6Mx4PTS	6.5	15.0	12.7	7.0	44.0	22.5	10	14
8	1/8	1171x8Mx2PTS	7.5	16.0	15.0	5.5	46.5	25.0	12	12
8	1/4	1171x8Mx4PTS	7.5	16.0	15.0	7.0	48.0	25.0	12	14
8	3/8	1171x8Mx6PTS	7.5	16.5	15.0	8.0	49.5	25.0	12	19
10	1/4	1171x10Mx4PTS	8.5	18.5	17.5	7.0	54.0	28.5	14	14
10	3/8	1171x10Mx6PTS	8.5	18.5	17.5	8.0	55.5	28.5	14	19
12	1/4	1171x12Mx4PTS	10.0	19.0	19.5	7.0	58.0	31.0	16	17
12	3/8	1171x12Mx6PTS	10.0	19.5	19.5	8.0	59.0	31.0	16	19
12	1/2	1171x12Mx8PTS	10.0	20.5	19.5	9.0	60.5	31.0	16	22

### Male Run Tee Swivel (BSPP)

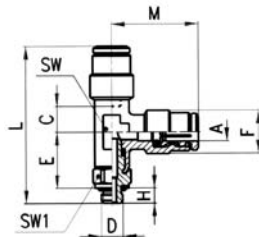

NOTE: Swivel for installation purposes only.  
\*M5 metric screw thread

Tube O.D. (mm)	Thread Size BSPP	Catalog Number	C	E	F	H	L	M	SW	SW1 (mm)
4	M5*	1171x4Mx5MMS	6	13	10	3.5	36.5	20	9	8
5	M5*	1171x5Mx5MMS	6	13	11	3.5	37.5	21	9	8

### Male Branch Tee Swivel (BSPT)

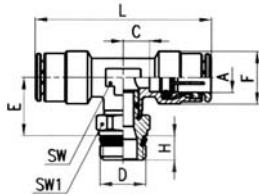

NOTE: Swivel for installation purposes only.

Tube O.D. (mm)	Thread Size BSP	Catalog Number	C	E	F	H	L	SW	SW1 (mm)
4	1/8	1172x4Mx2PTS	6.0	14.5	10.0	5.5	40	9	12
5	1/8	1172x5Mx2PTS	6.0	14.5	11.0	5.5	42	9	12
5	1/4	1172x5Mx4PTS	6.0	14.5	11.0	7.0	42	9	14
6	1/8	1172x6Mx2PTS	6.5	15.0	12.7	5.5	44	10	12
6	1/4	1172x6Mx4PTS	6.5	15.0	12.7	7.0	44	10	14
8	1/8	1172x8Mx2PTS	7.5	16.0	15.0	5.5	50	12	12
8	1/4	1172x8Mx4PTS	7.5	16.0	15.0	7.0	50	12	14
8	3/8	1172x8Mx6PTS	7.5	16.5	15.0	8.0	50	12	19
10	1/4	1172x10Mx4PTS	8.5	18.5	17.5	7.0	57	14	14
10	3/8	1172x10Mx6PTS	8.5	19.0	17.5	8.0	57	14	19
12	1/4	1172x12Mx4PTS	10.0	20.0	19.5	7.0	62	16	17
12	3/8	1172x12Mx6PTS	10.0	20.0	19.5	8.0	62	16	19
12	1/2	1172x12Mx8PTS	10.0	20.5	19.5	9.0	62	16	22

### Male Branch Tee Swivel (BSPP)

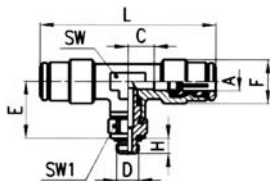

NOTE: Swivel for installation purposes only.  
\*M5 metric screw thread

Tube O.D. (mm)	Thread Size BSPP	Catalog Number	C	E	F	H	L	SW	SW1 (mm)
4	M5*	1172x4Mx5MMS	6	13	10	3.5	40	9	8
5	M5*	1172x5Mx5MMS	6	13	11	3.5	42	9	8

NOTE: M5 has 0.8 mm thread pitch. M5 seals with nylon washer, included.

# RIGHT ANGLE FLOW CONTROL AND NEEDLE VALVES

## SCU-MCU

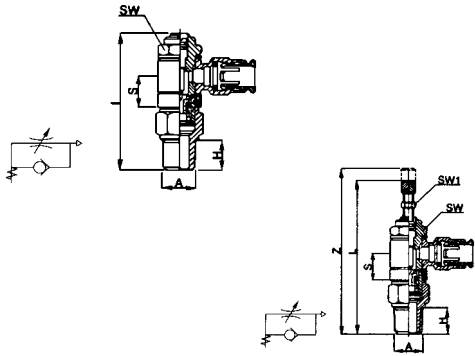

**Technical Data**

Valve:	Flow Regulator
Regulation:	Adjustable Screw
Material:	Brass; Nickel Plated
Seals:	Buna-N
Threads:	10-32UNF-1/8-1/4-3/8NPTF
Tube Sizes:	1/8 - 5/32 - 1/4 - 3/8
Operating Pressures:	to 150 PSI
Nominal Diameter:	10-32 UNF = .059 - 1/8 = .078
	1/4 = .157 - 3/8 = .275

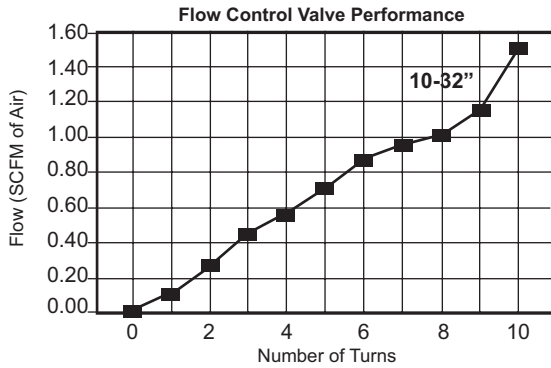

Air flow (SCFM) from B to A  
With adjustment open 1.9  
With adjustment closed 1.4

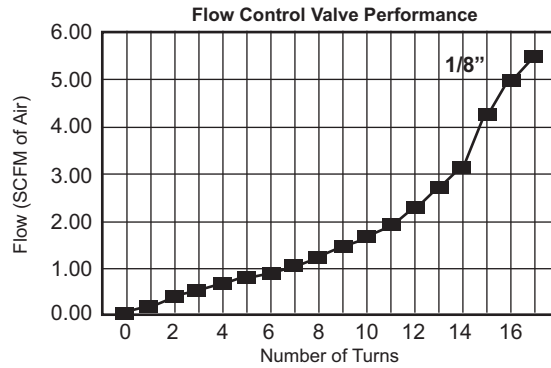

Air flow (SCFM) from B to A  
With adjustment open 5.7  
With adjustment closed 3.6

**Air flow is determined with 85 PSI at the in port and with 70 PSI at the outlet**

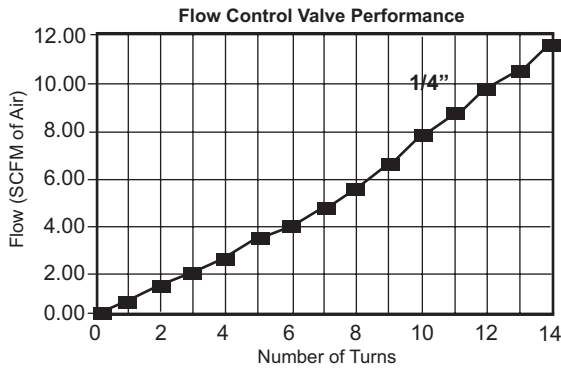

Air flow (SCFM) from B to A  
With adjustment open 15  
With adjustment closed 8

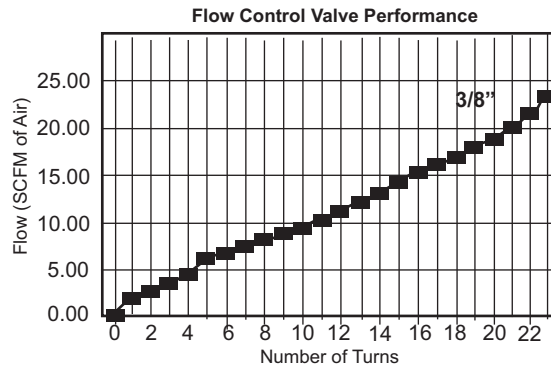

Air flow (SCFM) from B to A  
With adjustment open 23  
With adjustment closed 13

**Air flow is determined with 85 PSI at the in port and with 70 PSI at the outlet**

**NOTE:** We reserve the right to alter these specifications without prior notice.

These unidirectional and bidirectional flow controllers have been designed as small as possible so as to be mounted directly on valves or cylinders.

### Identification of flow control

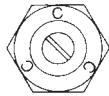

SCU  
MCU

### Coding of Banjo flow controllers

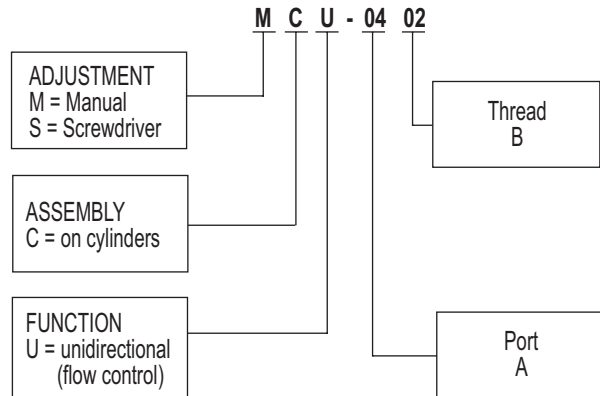

### SCU

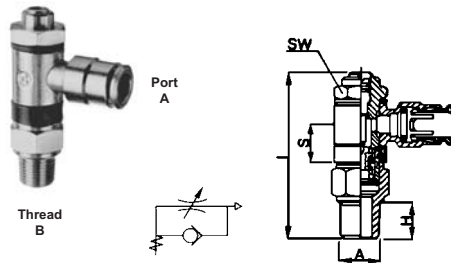

\*UNF Thread

Catalog Number	Tube O.D.	A NPTF	S	H	L	SW (mm)
A55SCUx2.5A	5/32	10-32*	.22	.18	1.14	8
A55SCUx2.5x2	5/32	1/8	.51	.37	2.00	14
A55SCUx4x2	1/4	1/8	.51	.37	2.00	14
A55SCUx4x4	1/4	1/4	.45	.51	2.25	17
A55SCUx6x4	3/8	1/4	.45	.51	2.25	17
A55SCUx6x6	3/8	3/8	.48	.51	2.44	19

### SCU

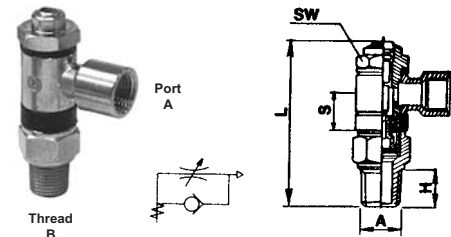

\*UNF Thread

Catalog Number	Banjo Female Thread	A NPTF	S	H	L	SW (mm)
A557SCUxAxA	5/16	10-32*	.22	.18	1.14	8
A557SCUx2x2	1/8	1/8	.51	.37	2.00	14
A557SCUx4x4	1/4	1/4	.45	.51	2.25	17
A557SCUx6x6	3/8	3/8	.48	.51	2.44	19

### MCU

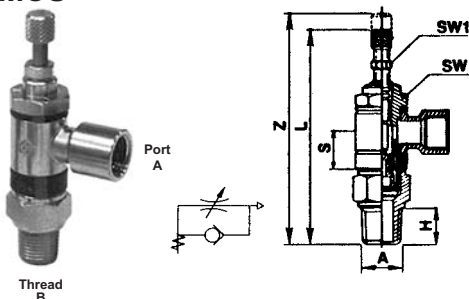

Catalog Number	Banjo Female Thread	A NPTF	S	H	L	Z	SW (mm)	SW1 (mm)
A557MCUx2x2	1/8	1/8	.51	.37	2.38	2.56	14	7
A557MCUx6x6	3/8	3/8	.48	.51	2.95	3.25	19	10

Weatherhead® is proud to announce three design changes to Weatherhead's Push > Connect™ fittings. The introduction of a low profile, sure-seal design for male NPTF threaded fittings is here. Also, an improved collet design will allow use with all types of tubing from Nylon to 90A durometer Polyurethane, including Polyethylene, and PVC tubing. Lastly, the male swivel design provides greater strength and stability.

Below is a summary of features and benefits for the newly named **Push > Connect™ Plus**.

**Perfect thread seal** – A captured Teflon® ring around the base of the hex shoulder, seals similar to a reusable (SAE type) seal eliminates thread sealant and loose particles associated with thread sealant.

**Lower profile** – Push > Connect™ Plus has a lower profile for those tight places. A shorter thread design eliminates exposed threads where dirt and bacteria can collect (ideal for food processing and hygienic applications).

**More versatility** – The new brass collet is designed for use with all types of tubing from Nylon to 90A durometer Polyurethane, including Polyethylene, and PVC tubing.

**Super-quick installations** – New short thread length means fewer turns and super-quick installations.

**Improved swivel design** – Strength and stability have been engineered into the new male swivel.

The new part will have a 'P' in the part number to signify the new design. An example of this change is previous #1169x4S becomes #1169Px4S and the price for old and new is the same. Current Push > Connect™ parts with 10-32UNF threads and ending in 'A' (eg. 1168x2A) will continue with the current thread design.

## Male "Y" Swivel

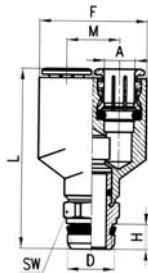

Tube O.D.	Male Pipe Thread	Catalog Number	F	H	M	L
1/8	1/8	1108Px2S	.83	.20	.39	1.28
5/32	1/8	1108Px2.5S	.83	.20	.39	1.28
1/4	1/8	1108Px4S	.96	.20	.49	1.40

## Male Connector

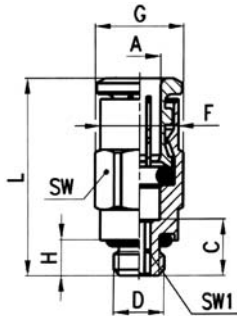

Tube O.D.	Male Pipe Thread	Catalog Number	F	G	H	L	SW (mm)	SW1 (mm)
1/8	10-32*	1168x2A	.346	.411	.177	.846	9	2.0
1/8	1/8	1168Px2	.346	.551	.200	.728	12	2.5
1/8	1/4	1168Px2x4	.346	.629	.255	.807	14	2.5
5/32	10-32*	1168x2.5A	.346	.411	.177	.807	9	2.0
5/32	1/8	1168Px2.5	.346	.551	.200	.728	12	2.5
5/32	1/4	1168Px2.5x4	.346	.629	.255	.807	14	2.5
1/4	10-32*	1168x4A	.460	.551	.177	.905	12	2.0
1/4	1/8	1168Px4	.460	.551	.200	.807	12	4.0
1/4	1/4	1168Px4x4	.460	.629	.255	.846	14	4.0
1/4	3/8	1168Px4x6	.460	.866	.294	.885	19	4.0
5/16	1/8	1168Px5	.539	.629	.200	.945	14	5.0
5/16	1/4	1168Px5x4	.539	.629	.255	.945	14	6.0
5/16	3/8	1168Px5x6	.539	.866	.294	.924	19	6.0
3/8	1/8	1168Px6x2	.641	.776	.200	1.082	17	5.0
3/8	1/4	1168Px6	.641	.776	.255	1.102	17	7.0
3/8	3/8	1168Px6x6	.641	.866	.294	.945	19	7.0
3/8	1/2	1168Px6x8	.641	1.004	.335	.984	22	7.0
1/2	3/8	1168Px8	.720	.866	.294	1.161	19	10.0
1/2	1/4	1168Px8x4	.720	.866	.255	1.161	19	7.0
1/2	1/2	1168Px8x8	.720	1.004	.335	1.062	22	10.0

\*UNF Thread



### Swivel Male Elbow

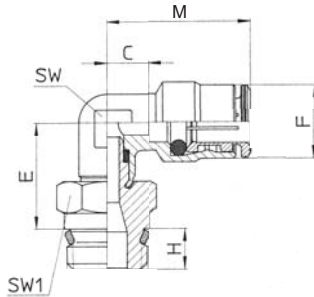

NOTE: Swivel for installation purposes only.

Tube O.D.	Male Pipe Thread	Catalog Number	C	E	F	H	L	SW (mm)	SW1 (mm)
1/8	1/8	1169Px2S	.24	.59	.35	.20	.81	9	12
1/8	1/4	1169Px2x4S	.24	.63	.35	.26	.81	9	14
5/32	1/8	1169Px2.5S	.24	.59	.35	.20	.79	9	12
5/32	1/4	1169Px2.5x4S	.24	.63	.35	.26	.79	9	14
1/4	1/8	1169Px4S	.27	.63	.46	.20	.89	10	12
1/4	1/4	1169Px4x4S	.27	.65	.46	.26	.89	10	14
1/4	3/8	1169Px4x6S	.27	.65	.46	.29	.89	12	19
5/16	1/8	1169Px5S	.30	.65	.54	.20	.96	12	12
5/16	1/4	1169Px5x4S	.30	.69	.54	.26	.96	12	14
5/16	3/8	1169Px5x6S	.30	.69	.54	.29	.96	12	19
3/8	1/8	1169Px6x2S	.34	.75	.64	.20	1.10	14	14
3/8	1/4	1169Px6S	.34	.77	.64	.26	1.10	14	14
3/8	3/8	1169Px6x6S	.34	.77	.64	.29	1.10	14	19
3/8	1/2	1169Px6x8S	.34	.79	.64	.34	1.10	14	22
1/2	1/4	1169Px8x4S	.39	.81	.72	.26	1.20	17	17
1/2	3/8	1169Px8S	.39	.81	.72	.29	1.20	17	19
1/2	1/2	1169Px8x8S	.39	.83	.72	.36	1.20	17	22

### Male Run Tee Swivel

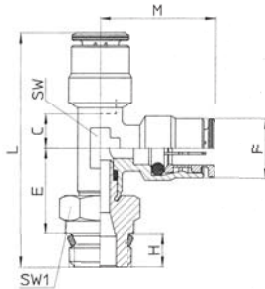

NOTE: Swivel for installation purposes only.

Tube O.D.	Male Pipe Thread	Catalog Number	C	E	F	H	L	M	SW (mm)	SW1 (mm)
1/8	1/8	1171Px2S	.24	.59	.35	.20	1.59	.81	9	12
5/32	1/8	1171Px2.5S	.24	.59	.35	.20	1.57	.79	9	12
5/32	1/4	1171Px2.5x4S	.24	.63	.35	.26	1.67	.79	9	14
1/4	1/8	1171Px4S	.27	.61	.46	.20	1.69	.89	10	12
1/4	1/4	1171Px4x4S	.27	.65	.46	.26	1.79	.89	10	14
1/4	3/8	1171Px4x6S	.27	.65	.46	.29	1.83	.89	12	19
3/8	1/4	1171Px6S	.34	.77	.64	.26	2.13	1.10	14	14
3/8	3/8	1171Px6x6S	.34	.77	.64	.29	2.17	1.10	14	19
3/8	1/2	1171Px6x8S	.34	.79	.64	.34	2.22	1.10	14	22
1/2	1/4	1171Px8x4S	.39	.81	.72	.26	2.26	1.20	17	17
1/2	3/8	1171Px8S	.39	.81	.72	.29	2.30	1.20	17	19
1/2	1/2	1171Px8x8S	.39	.83	.72	.34	2.36	1.20	17	22

### Male Branch Tee Swivel

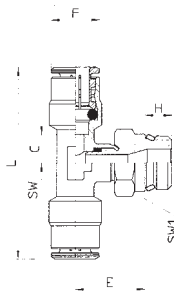

NOTE: Swivel for installation purposes only.

Tube O.D.	Male Pipe Thread	Catalog Number	C	E	F	H	L	SW (mm)	SW1 (mm)
1/8	1/8	1172Px2S	.24	.59	.35	.20	1.61	9	12
5/32	1/8	1172Px2.5S	.24	.59	.35	.20	1.57	9	12
5/32	1/4	1172Px2.5x4S	.24	.63	.35	.26	1.57	9	14
1/4	1/8	1172Px4S	.27	.61	.46	.20	1.77	10	12
1/4	1/4	1172Px4x4S	.27	.65	.46	.26	1.77	10	14
1/4	3/8	1172Px4x6S	.27	.65	.46	.29	1.77	12	19
3/8	1/4	1172Px6S	.34	.77	.64	.26	2.20	14	14
3/8	3/8	1172Px6x6S	.34	.77	.64	.29	2.20	14	19
3/8	1/2	1172Px6x8S	.34	.79	.64	.34	2.20	14	22
1/2	1/4	1172Px8x4S	.39	.81	.72	.26	2.40	17	17
1/2	3/8	1172Px8S	.39	.81	.72	.29	2.40	17	19
1/2	1/2	1172Px8x8S	.39	.83	.72	.34	2.40	17	22

\*UNF Thread

 Refer to safety information regarding proper selection of tubing and tube fittings on page 1.

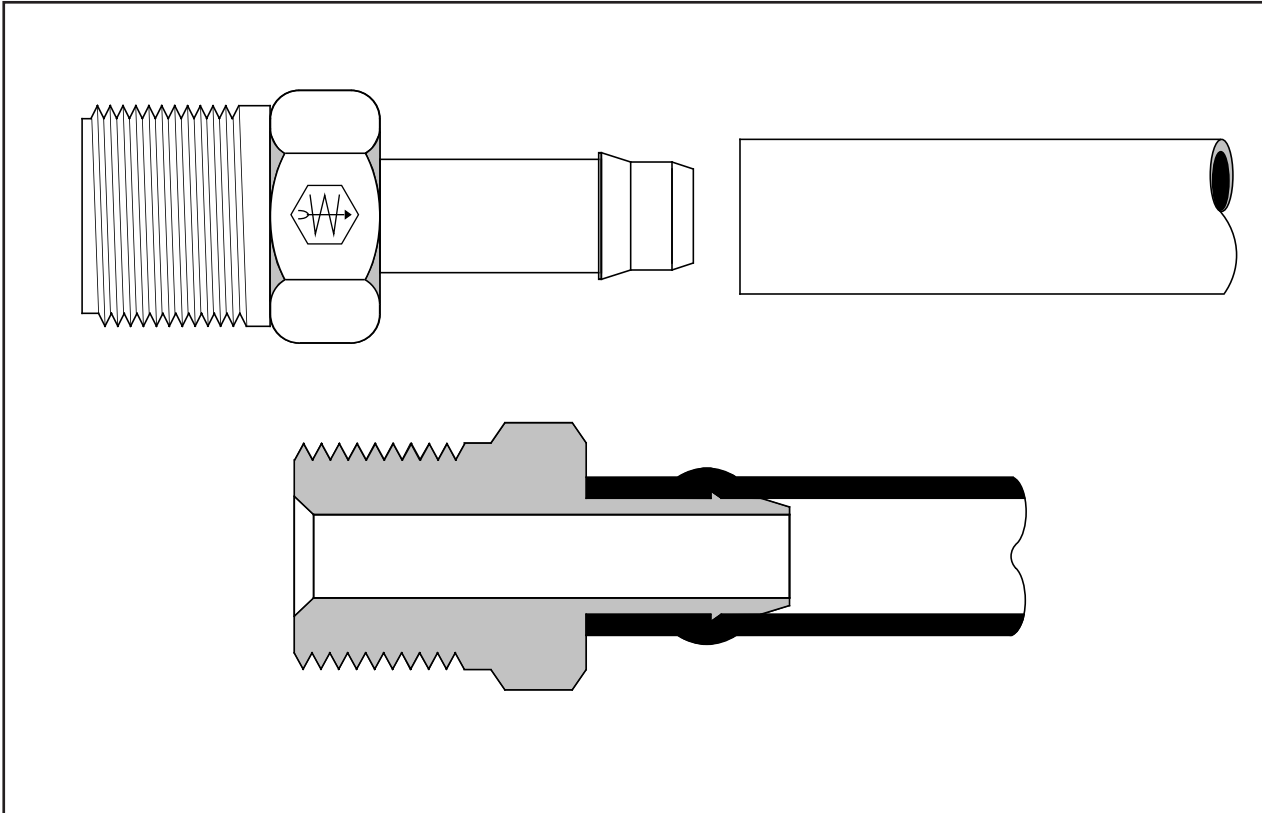

• **Typical Application**

Temperature control circuits, test apparatus, lubricant, coolant lines, pneumatic circuits, vacuum and fluid systems.

• **Pressure**

Will stand burst pressures of plastic tubing.

• **Vibration**

Excellent resistance.

• **Temperature Range**

Depends on tubing used.

• **Material**

CA360 Brass.

• **Used With**

PT240 Polyethylene tubing. See page 28-32 for material compatibility and page 34 for plastic tubing.

• **Advantages**

Quick connecting - no tube preparation. Hand assembly. Low cost one-piece push-on design. Barbed lip provides safe, positive connection. Compact size permits use in extremely tight areas.

• **Conformance**

An exclusive item with Weatherhead. User approvals only.

• **How to Order**

Individually by catalog number.

• **NOTE**

Refer to current price list for availability of cataloged items. Quotations and delivery of non-stock items supplied on request. Configurations and dimensions subject to change without notice.

• **Assembly Instructions**

1. Push the tubing over insert.
2. Bottom the tubing against fitting body.

**Label Set:** **FS-1000** (adhesive)  
**CL-496** (non-adhesive)

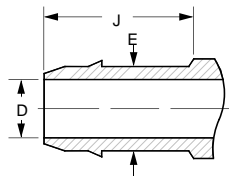

Common Dimensions of Barbed End

Tubing O.D.	D	E	J
5/32	.062	.113	.38
*3/16	.078	.125	.50
1/4	.127	.189	.50
3/8	.196	.270	.50
1/2	.312	.395	.63

\*No barb on 3/16" size.

### Plug

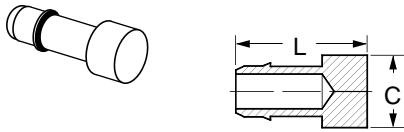

Tubing O.D.	Catalog Number	Dia. C	L
1/4	1073x4	.31	.75
3/8	1073x6	.40	.75
1/2	1073x8*	.53	.88

### Solder Connector

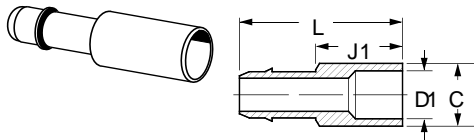

Tubing O.D.	Solder Conn.	Catalog Number	Dia. C	D1	J1	L
1/4	1/4	1079x4x4	5/16	.25	.50	1.00

### Union

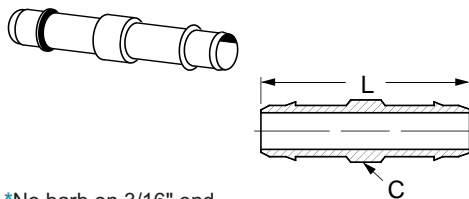

\*No barb on 3/16" end.  
"L" Suffix designates long Union.

Tubing O.D.	Catalog Number	Dia. C	L
1/4x3/16*	1062x4x3	1/4	1.25
1/4	1062x4	1/4	.81
1/4	1062x4L	1/4	1.25
3/8x1/4	1062x6x4	5/16	1.19
3/8	1062x6	5/16	1.19
1/2x1/4	1062x8x4*	1/2	1.33
1/2x3/8	1062x8x6	1/2	1.33
1/2	1062x8	1/2	1.45

### Male Connector

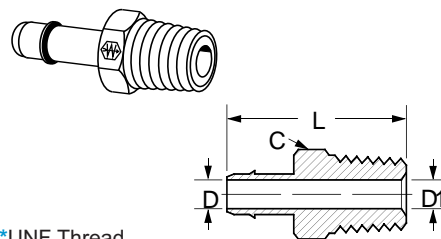

\*UNF Thread

Tubing O.D.	Male Pipe Thread	Catalog Number	Hex C	D	D1 Opt.	L
1/8	10-32*	1068x2A*	5/16	.04	.09	.84
5/32	1/8	1068x2.5x2	7/16	.06	.19	.98
1/4	1/16	1068x4x1	5/16	.12	-	1.06
1/4	1/8	1068x4	7/16	.12	.19	1.06
1/4	1/4	1068x4x4	9/16	.12	.28	1.28
3/8	1/8	1068x6x2	7/16	.19	-	1.09
3/8	1/4	1068x6	9/16	.19	.28	1.28
3/8	1/2	1068x6x8*	7/8	.19	.56	1.41
1/2	3/8	1068x8	11/16	.31	-	1.38

### Female Connector

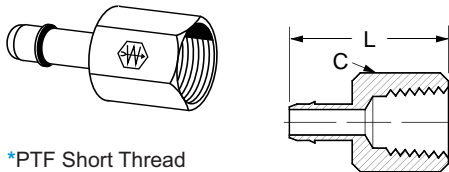

\*PTF Short Thread

Tubing O.D.	Fem. Pipe Thread	Catalog Number	Hex C	L
1/4	1/16	1066x4x1*	7/16	.97
1/4	1/8*	1066x4	1/2	1.00
1/4	1/4	1066x4x4	11/16	1.25
3/8	1/4	1066x6*	11/16	1.25
1/2	3/8	1066x8*	13/16	1.31

### Compression Connector

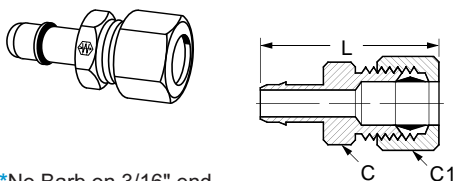

\*No Barb on 3/16" end  
For replacement nuts and sleeves see page 48.

Tubing O.D.	Comp. Tube Size	Catalog Number	Hex C	Hex C1	L
3/16*	1/4	1078x3x4	7/16	1/2	1.29
1/4	1/4	1078x4x4	7/16	1/2	1.29

\*MTO - Made To Order

## Bulkhead Compression Connector

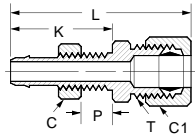
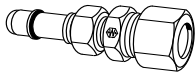

For replacement compression nuts and sleeves, see page 48.

Tubing O.D.	Comp. Tube Size	Catalog Number	Hex C	Hex C1	K	L	Max. P	T Thread
1/4	1/4	1067x4x4	7/16	1/2	.88	1.66	.19	5/16-24 UNF
3/8	3/8	1067x6x6♦	9/16	5/8	1.06	1.94	.31	3/8-24 UNF

## Bulkhead Union

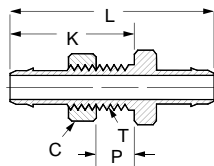
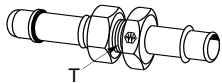

For replacement nuts and sleeves, see page 49.

Tubing O.D.	Thread T	Catalog Number	Hex C	K	L	Max. P
1/4	5/16-24 UNF	1074x4	7/16	1.06	1.74	.31
3/8	3/8-24 UNF	1074x6	1/2	1.06	1.74	.31
1/2	1/2-24 UNF	1074x8♦	5/8	1.19	1.99	.31

## Union Elbow

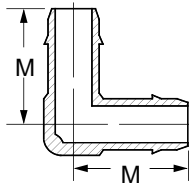
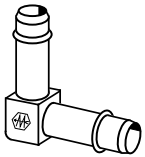

Tubing O.D.	Catalog Number	M
1/4	1065x4	.70
3/8	1065x6	.67
1/2	1065x8	.86

## 90° Male Elbow

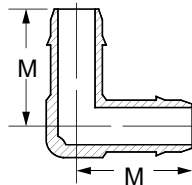
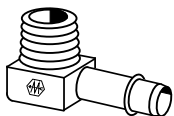

\*PTF Short Thread

Tubing O.D.	Male Pipe Thread	Catalog Number	D1	M	N
1/4	1/16	1069x4x1	.156	.67	.55
1/4	1/8	1069x4	.250	.72	.63
1/4	1/4*	1069x4x4	.312	.78	.65
3/8	1/8	1069x6x2	.250	.74	.59
3/8	1/4*	1069x6	.312	.78	.62
1/2	3/8*	1069x8	.406	.98	.81

## 90° Female Elbow

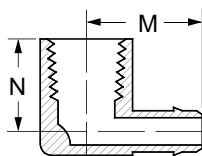
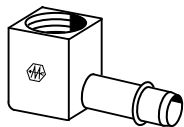

Tubing O.D.	Fem. Pipe Thread	Catalog Number	M	N
1/4	1/16	1070x4x1♦	.78	.44
1/4	1/8	1070x4	.75	.58
1/4	1/4	1070x4x4♦	.85	.56
3/8	1/8	1070x6x2	.78	.48
3/8	1/4	1070x6	.84	.81
1/2	3/8	1070x8♦	1.03	.75

### Union Tee

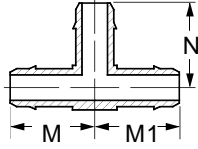
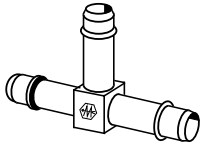

Tubing O.D.	Catalog Number	M	N	M1
1/4	1064x4	.70	.70	.70
3/8x3/8x1/4	1064x6x6x4	.70	.74	.70
3/8	1064x6	.68	.67	.68
3/8x1/2x3/8	1064x6x8x6	.67	.73	.79
1/2x1/2x1/4	1064x8x8x4	.82	.80	.82
1/2x1/2x3/8	1064x8x8x6	.79	.73	.79
1/2	1064x8	.86	.86	.86

### Male Run Tee

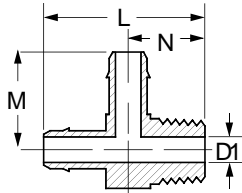
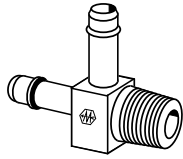

\*PTF Short Thread

Tubing O.D.	Male Pipe Thread	Catalog Number	D1	L	M	N
1/4	1/16	1071x4x1♦	.125	1.20	.71	.59
1/4	1/8	1071x4	.188	1.21	.71	.59
3/8	1/8	1071x6x2♦	.188	1.26	.71	.59
3/8	1/4*	1071x6♦	.312	1.26	.78	.61
1/2	3/8	1071x8♦	.406	1.84	.97	1.00

### Male Branch Tee

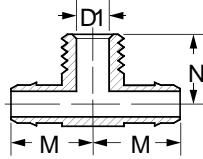
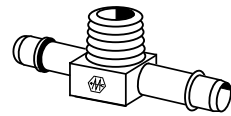

Tubing O.D.	Male Pipe Thread	Catalog Number	D1	M	N
1/4	1/16	1072x4x1♦	.156	.67	.55
1/4	1/8	1072x4	.188	.72	.59
3/8	1/8	1072x6x2	.188	.72	.59
3/8	1/4	1072x6	.312	.78	.62
1/2	3/8	1072x8♦	.406	.98	.81

### Female Branch Tee

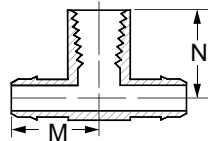
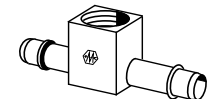

Tubing O.D.	Female Pipe Thread	Catalog Number	M	N
1/4	1/8	1077x4	.77	.48
1/4	1/4	1077x4x4♦	.85	.56

### Adapter Tee

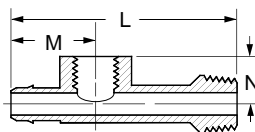
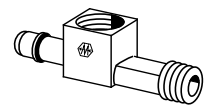

\*PTF Special Short Thread

Tubing O.D.	M&F Pipe Thread	Catalog Number	L	M	N
1/4	1/8*	1075x4	2.00	.75	.39

♦MTO - Made To Order

 Refer to safety information regarding tubing selection on page 1.

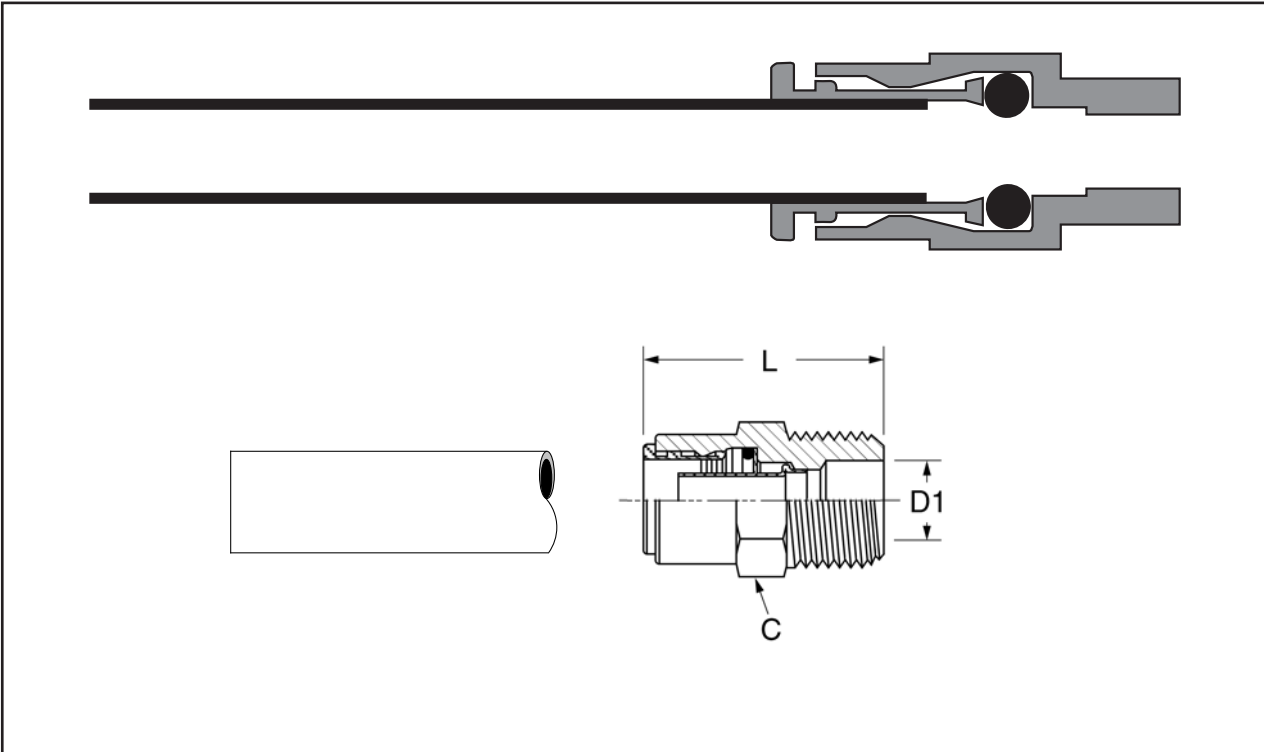

• **Typical Application**

Air brake systems except where temperatures exceed +200°F or where battery acid can drip on tubing.

• **Pressure**

Vacuum to 150 psi.

• **Vibration**

Moderate vibration resistance.

• **Material**

CA360 Brass (Body & Collet).  
EP (Ethylene Propylene) - O-ring.

• **Used With**

NT100 Nylon Tubing - SAE J844  
Type A and B. See page 33 for NT100  
Nylon Tubing data.

• **Temperature Range**

-40°F to +200°F (-40°C to +93°C)

• **Advantages**

Easy, fast assembly, one-piece fitting,  
reusable Field Serviceable.

• **Conformance**

Meets D.O.T. FMVSS 571.106 and  
SAE J1131 air brake system per-  
formance requirements.

• **How to Order**

Order individually by catalog number  
(parts are standard with thread seal-  
ant).

• **NOTE**

Refer to current price list for availabil-  
ity of cataloged items. Quotations  
and delivery of non-stock items sup-  
plied on request. Configurations and  
dimensions subject to change without  
notice.

• **Assembly Instructions**

See following page.

• **Cartridge Information**

**Encapsulated** – For insertion into sin-  
gle bore cavity in substitution for  
pipe thread ports. Meets proposed  
SAE specifications for encapsulated  
press in style Air Brake Fittings. Note:  
Weatherhead Encapsulated  
Cartridges are specifically designed  
for installation into a thermoplastic  
(Nylon/Glass filled Nylon/Acetal) or a  
soft metal (Aluminum/Brass) cavity.  
For cavity dimensions contact 1-800-  
336-5005.

**Four-Step Cartridge** – When you  
clean sheet a component design, the  
Four-Step Cartridge is an economical  
substitute for the encapsulated design.  
Special order only.

Select the design that is right for you.  
For applications where manifolds (man-  
ufactured from aluminum, plastic and  
brass) and air tanks (manufactured from  
steel and plastic composites) are used,  
contact Dana Weatherhead Sales Dept.,  
Antwerp, OH, at 1-800-336-5005 for  
quotes based on your specific require-  
ments and volumes.

**Label Set:** **FS-3300** (adhesive)  
**CL-503** (non-adhesive)

### Assembly

1. Using a tube cutter, make a square cut edge (maximum 15° cutting angle allowed).

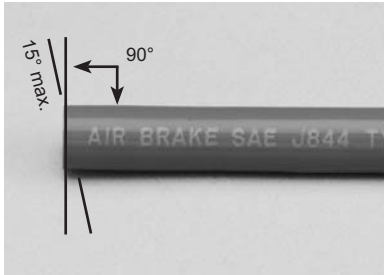

2. Insert tubing straight into fitting until a solid stop is felt. The tubing grip and seal (on O-ring) is now accomplished.

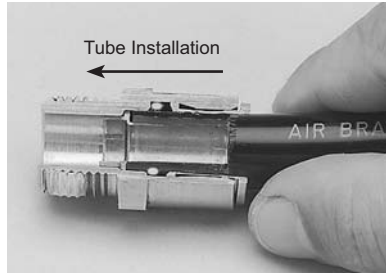

3. Gently tug on tubing to ensure tubing is secure.

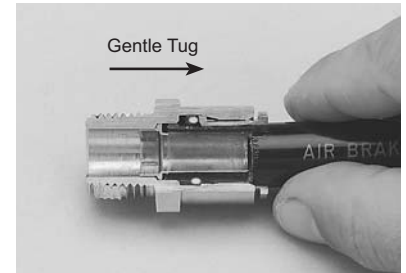

### Disassembly

1. Check to be sure there isn't any air pressure.

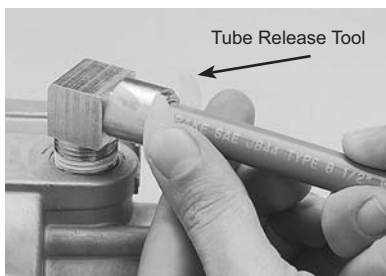

2. Depress collet head using fingers or Weatherhead<sup>®</sup> tube-release tool to release grip on tubing.

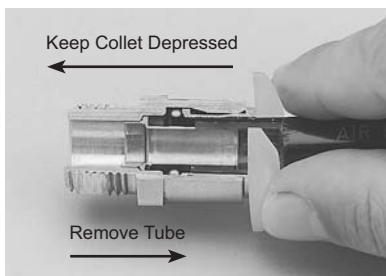

3. With the collet depressed, pull the tubing from the fitting.

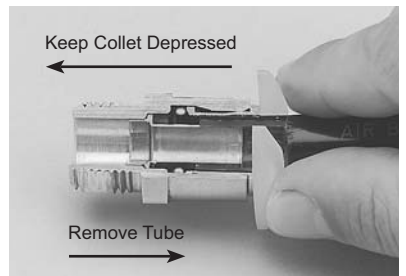

Use with Weatherhead NT100 Air Brake Tubing (SAE J844)

## Encapsulated Cartridge

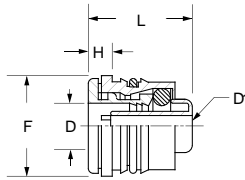
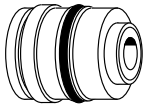

**NOTE:** For design installation reference page 84 under Encapsulated heading.

Tube O.D.	Catalog Number	Dia F	L	D1	D	H
5/32	<a href="#">1861x2.5</a>	.38	.62	.12	.165	.17
3/16	<a href="#">1861x3</a>	.44	.62	.12	.195	.16
1/4	<a href="#">1861x4</a>	.56	.65	.13	.263	.17
3/8	<a href="#">1861x6</a>	.69	.81	.22	.388	.19
1/2	<a href="#">1861x8</a>	.81	.83	.34	.513	.19
5/8	<a href="#">1861x10</a>	.97	.99	.40	.638	.24
3/4	<a href="#">1861x12</a>	1.12	.99	.52	.763	.24

## Union

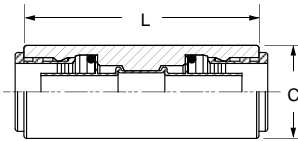

**NOTE:** Joins tubing

Tube O.D.	Catalog Number	Dia C	L
5/32	<a href="#">1862x2.5</a>	.44	1.41
1/4	<a href="#">1862x4</a>	.53	1.62
3/8	<a href="#">1862x6</a>	.69	1.94
1/2	<a href="#">1862x8</a>	.83	1.96
5/8	<a href="#">1862x10</a>	.96	2.51

## Quick Connect Bulkhead Union

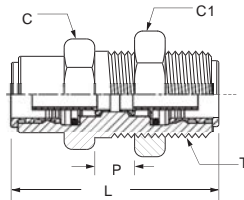
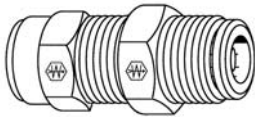

Tube O.D.	Tread T	Catalog Number	Hex C	Hex C1	L	Max P
1/4	9/16-24	<a href="#">1874x4x4</a>	5/8	11/16	1.62	.47
3/8	3/4-16	<a href="#">1874x6x6</a>	7/8	15/16	1.96	.66
1/2	7/8-14	<a href="#">1874x8x8</a>	1	1	2.00	.83
5/8	1-14	<a href="#">1874x10x10</a>	1	1-1/4	2.42	1.00

## Female Bulkhead Union

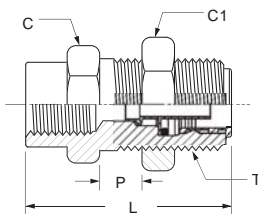
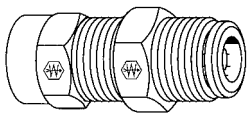

Tube O.D.	Thread T	Female Pipe Thread	Catalog Number	Hex C	Hex C1	L
1/4	9/16-24	1/4	<a href="#">1873x4x4</a>	5/8	11/16	1.45
3/8	3/4-16	3/8	<a href="#">1873x6x6</a>	7/8	15/16	1.59
1/2	1-14	1/2	<a href="#">1873x8x8</a>	1	1-1/4	1.97



# Quick > Connect<sup>®</sup> Air Brake

**Brass  
Fittings**

Use with Weatherhead NT100 Air Brake Tubing (SAE J844)

## Male Connector

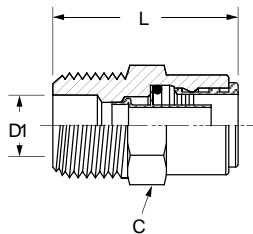
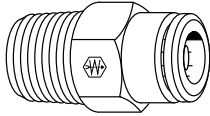

Tube O.D.	Male Pipe Thread	Catalog Number	Hex C	D1	L
5/32	1/16	1868x2.5x1	3/8	.09	.92
5/32	1/8	1868x2.5	7/16	.25	.92
3/16	1/8	1868x3	1/2	.25	.92
1/4	1/8	1868x4	9/16	.19	.95
1/4	1/4	1868x4x4	9/16	.34	1.18
1/4	3/8	1868x4x6	11/16	.41	1.18
3/8	1/8	1868x6x2	11/16	.19	1.33
3/8	1/4	1868x6	11/16	.31	1.30
3/8	3/8	1868x6x6	11/16	.41	1.29
3/8	1/2	1868x6x8	7/8	.53	1.48
1/2	1/4	1868x8x4	13/16	.31	1.48
1/2	3/8	1868x8	13/16	.41	1.37
1/2	1/2	1868x8x8	7/8	.53	1.72
5/8	3/8	1868x10x6	1	.41	1.72
5/8	1/2	1868x10	1	.53	1.73
3/4	1/2	1868x12	1-1/16	.53	1.95

## Female Connector

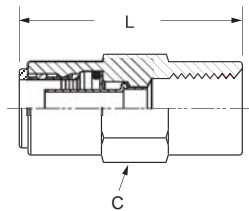
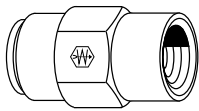

Tube O.D.	Female Pipe Thread	Catalog Number	Hex C	L
1/4	1/8	1866x4	9/16	1.33
1/4	1/4	1866x4x4	11/16	1.58
3/8	1/8	1866x6x2	11/16	1.45
3/8	1/4	1866x6	11/16	1.69
3/8	3/8	1866x6x6	13/16	1.75
1/2	1/4	1866x8x4	13/16	1.66
1/2	3/8	1866x8	13/16	1.73
1/2	1/2	1866x8x8	1	1.97

BRASS

Use with Weatherhead NT100 Air Brake Tubing (SAE J844)

## Male Elbow 45°

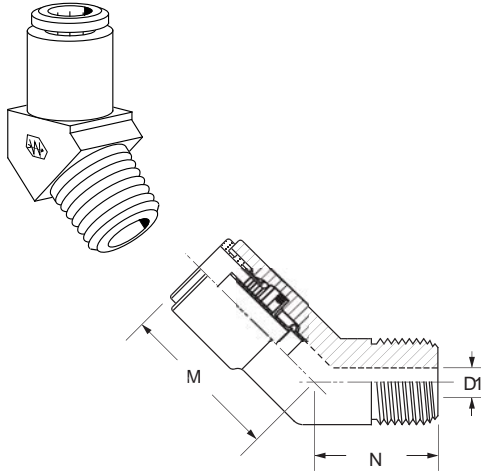

Tube O.D.	Male Pipe Thread	Catalog Number	D1	M	N
1/4	1/8	1880x4	.19	.95	.60
1/4	1/4	1880x4x4	.31	.95	.60
3/8	1/8	1880x6x2	.25	1.05	.50
3/8	1/4	1880x6	.31	1.05	.69
3/8	3/8	1880x6x6	.41	1.10	.63
3/8	1/2	1880x6x8	.53	1.20	.70
1/2	1/4	1880x8x4	.31	1.20	.87
1/2	3/8	1880x8	.41	1.11	.74
1/2	1/2	1880x8x8	.53	1.11	.78
5/8	3/8	1880x10x6	.41	1.23	.82
5/8	1/2	1880x10	.53	1.39	.91
3/4	1/2	1880x12	.53	1.26	.98

## Swivel Male 45° Elbow

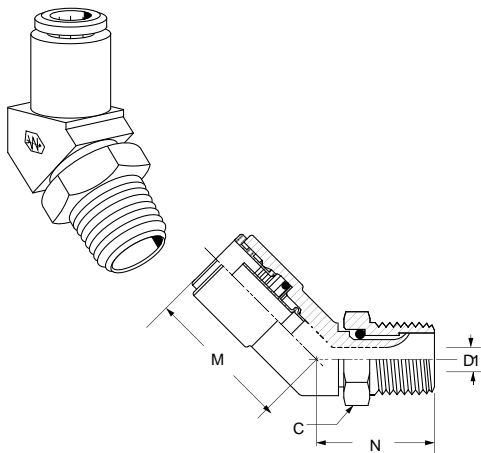

Tube O.D.	Male Pipe Thread	Catalog Number	D1	M	N	Hex C
1/4	1/8	1880x4S	.13	.82	.60	7/16
1/4	1/4	1880x4x4S	.22	.98	.60	9/16
3/8	1/8	1880x6x2S	.13	1.20	.68	7/16
3/8	1/4	1880x6S	.22	1.20	.82	9/16
3/8	3/8	1880x6x6S	.30	1.20	.97	11/16
1/2	1/4	1880x8x4S	.22	1.20	1.20	9/16
1/2	3/8	1880x8S	.30	1.04	1.07	11/16
1/2	1/2	1880x8x8S	.42	1.08	1.22	7/8

NOTE: Swivel for installation purposes only.

## Union Elbow

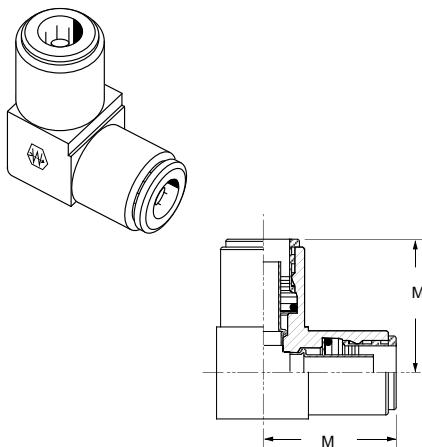

Tube O.D.	Catalog Number	M
1/4	1865x4	.93
3/8	1865x6	1.15
1/2	1865x8	1.24

# Quick > Connect® Air Brake

**Brass  
Fittings**

Use with Weatherhead NT100 Air Brake Tubing (SAE J844)

## Male Elbow 90°

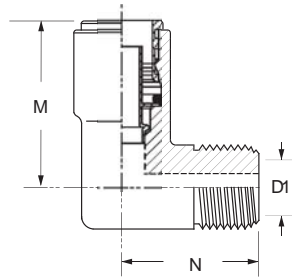
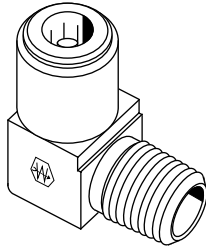

Tube O.D.	Male Pipe Thread	Catalog Number	D1	M	N
5/32	1/16	1869x2.5x1	.13	.75	.59
5/32	1/8	1869x2.5	.19	.75	.59
3/16	1/8	1869x3	.19	.84	.69
1/4	1/8	1869x4	.19	.96	.68
1/4	1/4	1869x4x4	.31	.92	.82
1/4	3/8	1869x4x6	.41	1.03	.83
3/8	1/8	1869x6x2	.19	1.07	.80
3/8	1/4	1869x6	.31	1.21	.97
3/8	3/8	1869x6x6	.41	1.20	.99
3/8	1/2	1869x6x8	.53	1.21	1.02
1/2	1/4	1869x8x4	.31	1.26	1.02
1/2	3/8	1869x8	.41	1.26	.99
1/2	1/2	1869x8x8	.53	1.26	1.12
5/8	3/8	1869x10x6	.41	1.44	1.10
5/8	1/2	1869x10	.53	1.48	1.23

## Male Elbow 90° Long

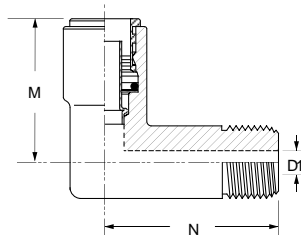
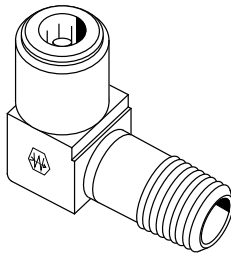

Tube O.D.	Male Pipe Thread	Catalog Number	D1	M	N
3/8	1/4	1869x6L	.31	1.21	1.55

BRASS

Use with Weatherhead NT100 Air Brake Tubing (SAE J844)

## Swivel Male 90° Elbow

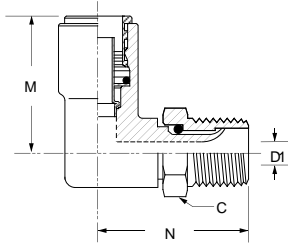
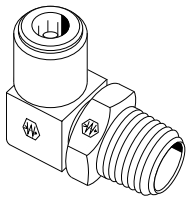

**NOTE:** Swivel for installation purposes only.

Tube O.D.	Male Pipe Thread	Catalog Number	D1	M	N	Hex C
1/4	1/8	1869x4S	.13	.89	.88	7/16
1/4	1/4	1869x4x4S	.22	.99	1.08	9/16
1/4	3/8	1869x4x6S	.30	.98	1.10	11/16
3/8	1/8	1869x6x2S	.13	1.03	.99	7/16
3/8	1/4	1869x6S	.22	1.22	1.16	9/16
3/8	3/8	1869x6x6S	.30	1.12	1.19	11/16
3/8	1/2	1869x6x8S	.42	1.18	1.40	7/8
1/2	1/4	1869x8x4S	.22	1.09	1.22	9/16
1/2	3/8	1869x8S	.30	1.13	1.27	11/16
1/2	1/2	1869x8x8S	.42	1.20	1.47	7/8
5/8	3/8	1869x10x6S	.42	1.35	1.34	11/16
5/8	1/2	1869x10S	.42	1.38	1.54	7/8

## Female Elbow

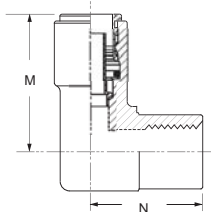
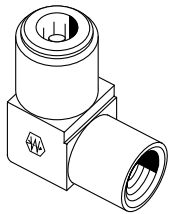

Tube O.D.	Female Pipe Thread	Catalog Number	M	N
1/4	1/8	1870x4	1.03	.83
1/4	1/4	1870x4x4	1.04	.78
3/8	1/8	1870x6x2	1.11	.96
3/8	1/4	1870x6	1.28	1.09
3/8	3/8	1870x6x6	1.21	1.07
1/2	1/4	1870x8x4	1.25	1.11
1/2	3/8	1870x8	1.22	1.11
1/2	1/2	1870x8x8	1.33	1.07

## Union Tee

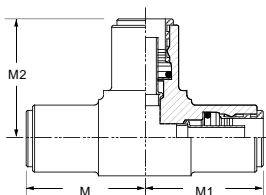
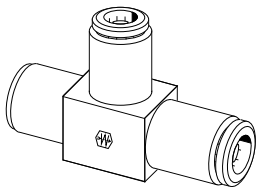

Tube O.D.	Catalog Number	M	M1	M2
1/4	1864x4	.93	.93	.93
3/8	1864x6	1.15	1.15	1.15
1/2	1864x8	1.25	1.25	1.25

# Quick > Connect<sup>®</sup> Air Brake

**Brass  
Fittings**

Use with Weatherhead NT100 Air Brake Tubing (SAE J844)

## Male Run Tee

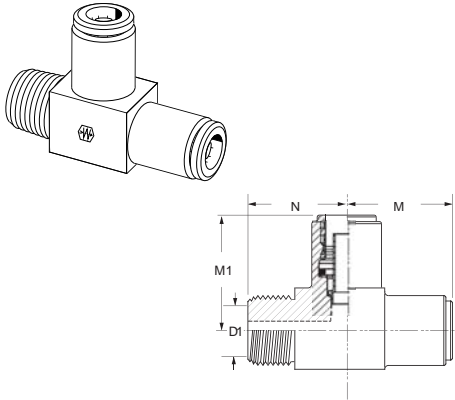

Tube O.D.	Male Pipe Thread	Catalog Number	D1	M	M1	N
1/4	1/8	1871x4	.19	.93	.93	.64
1/4	1/4	1871x4x4	.19	.93	.94	.83
3/8	1/4	1871x6	.31	1.15	1.15	.92
3/8	3/8	1871x6x6	.41	1.15	1.15	.92
3/8x1/4	1/4	1871x6x4x4	.31	1.14	1.07	.98
3/8	1/2	1871x6x8	.53	1.09	1.08	1.11
1/2	3/8	1871x8	.41	1.09	1.10	1.22

## Swivel Male Run Tee

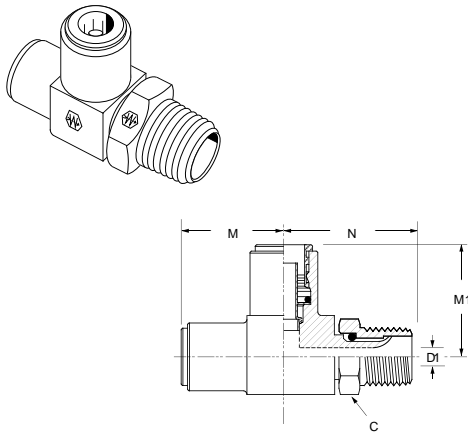

NOTE: Swivel for installation purposes only.

Tube O.D.	Male Pipe Thread	Catalog Number	D1	M	M1	N	Hex C
1/4	1/8	1871x4S	.13	.92	.92	.82	7/16
1/4	1/4	1871x4x4S	.22	.93	.92	1.07	9/16
3/8	1/4	1871x6S	.22	1.15	1.15	1.20	9/16
3/8	3/8	1871x6x6S	.30	1.15	1.15	1.23	11/16
1/2	1/4	1871x8x4S	.22	1.21	1.18	1.22	9/16
1/2	3/8	1871x8S	.30	1.21	1.23	1.34	11/16
1/2	1/2	1871x8x8S	.42	1.21	1.19	1.42	7/8

## Male Branch Tee

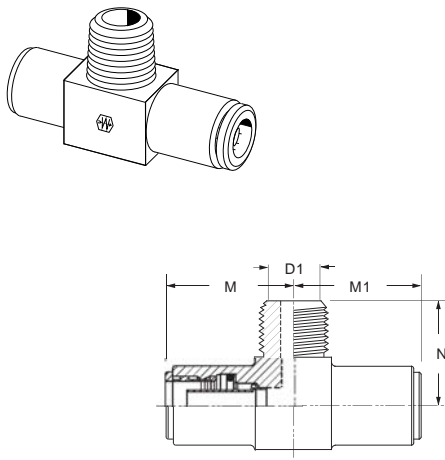

Tube O.D.	Male Pipe Thread	Catalog Number	D1	M	M1	N
3/16	1/8	1872x3	.19	.75	.74	.64
1/4	1/8	1872x4	.19	.93	.93	.93
1/4	1/4	1872x4x4	.19	.93	.93	.83
3/8	1/4	1872x6	.31	1.15	1.15	.92
3/8	3/8	1872x6x6	.31	1.15	1.15	.92
1/2	1/4	1872x8x4	.31	1.22	1.22	.98
1/2	3/8	1872x8	.41	1.24	1.24	.99
1/2	1/2	1872x8x8	.53	1.22	1.22	1.12

B  
R  
A  
S  
S

Use with Weatherhead NT100 Air Brake Tubing (SAE J844)

## Swivel Male Branch Tee

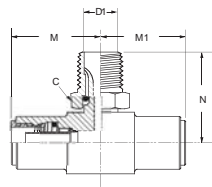
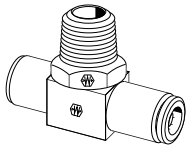

**NOTE:** Swivel for installation purposes only.

Tube O.D.	Male Pipe Thread	Catalog Number	D1	M	M1	N	Hex C
1/4	1/8	1872x4S	.13	.93	.93	.83	7/16
1/4	1/4	1872x4x4S	.22	.93	.93	1.04	9/16
3/8	1/8	1872x6x2S	.13	1.15	1.15	.94	7/16
3/8	1/4	1872x6S	.22	1.15	1.15	1.14	9/16
3/8	3/8	1872x6x6S	.30	1.15	1.15	1.17	11/16
1/2	1/4	1872x8x4S	.22	1.23	1.23	1.21	9/16
1/2	3/8	1872x8S	.30	1.24	1.24	1.24	11/16
1/2	1/2	1872x8x8S	.42	1.21	1.19	1.42	7/8

## Female Branch Tee

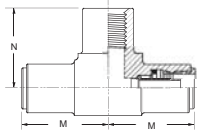
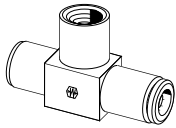

Tube O.D.	Female Pipe Thread	Catalog Number	M	N
3/8	1/4	1877x6	1.16	.78

## Adapter Tee

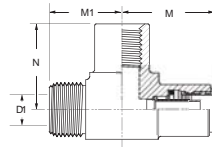
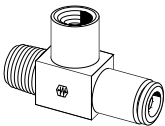

Tube O.D.	Male Pipe Thread	Female Pipe Thread	Catalog Number	D1	M	N	M1
3/8	3/8	1/4	1883x6x6x4	.41	1.28	1.00	.95

## Plugs, Pressure (Nylon)

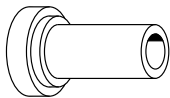

Tube O.D.	Catalog Number
1/4	1829x4
3/8	1829x6
1/2	1829x8

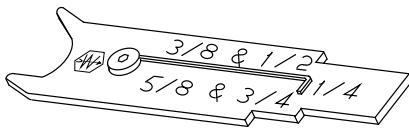

## 1800T • Collet Service Tool

The Collet Service Tool, made from sturdy plated steel, is designed to assist in field servicing O-Rings of Q-CAB® fittings. Use the half moon radius section to pry up and remove the collet and use the movable piano wire to remove the O-Ring. Notches are used to mark the tubing with insertion depth in five tubing sizes.



## 1800TRK • Tube Release Kit

The 1800TRK tube release kit is designed to ease the removal of tubing from Q-CAB® fittings. The individual tools are manufactured of a sturdy engineering plastic. All six tube sizes currently offered in Q-CAB® can be serviced with the five tools that make up the 1800TRK kit.

Tube O.D.	Repair Kit Part #
5/32	1800Kx2.5
3/16	1800Kx3
1/4	1800Kx4
3/8	1800Kx6
1/2	1800Kx8
5/8	1800Kx10
3/4	1800Kx12

## Collet Repair Kits

Consisting of a replacement collet and a replacement o-ring, the collet repair kits provide an opportunity to repair damaged Q-CAB® Fittings.

# Air Brake - Nylon Tubing

**Brass  
Fittings**

 Refer to safety information regarding tubing selection on page 1.

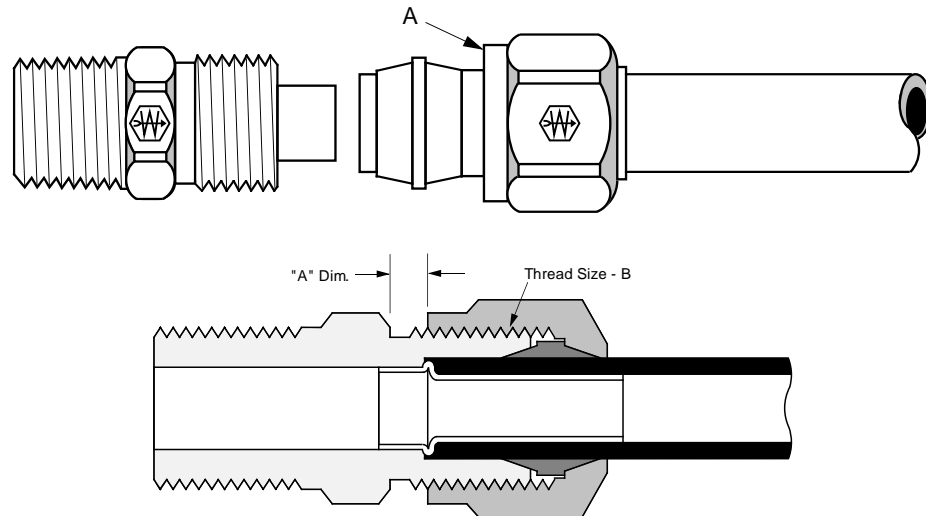

Tube O.D.	1/4	3/8	1/2	5/8	3/4
Thread Size-B	7/16-24	17/32-24	11/16-20	13/16-18	1-18

- Typical Application**  
 Air brake systems except where temperatures exceed +200°F or where battery acid can drip on tubing.
- Pressure**  
 Maximum operating pressure of 150 psi.
- Vibration**  
 Fair resistance.
- Temperature Range**  
 -40°F to +200°F (-40°C to +93°C)
- Material**  
 CA360 Brass.
- Used With**  
 NT100 Nylon Tubing - SAE J844 Type A and B. See page 33 for NT100 Nylon Tubing data.
- Advantages**  
 Easy to assemble (no tube preparation or flaring required.) Built in tube support. May be used with copper tubing by replacing nut, sleeve and insert with long nut and spherical sleeve. Insert should be removed for copper tubing use. See page 99 for details.

- Conformance**  
 Meets specifications and standards of SAE and DOT FMVSS 571.106.
- How to Order**  
 For complete assemblies (body, nuts and sleeves), order by catalog number. Example: 1468x4x4. To order body only (less nut and sleeve), add prefix "B" to catalog number and change "14" to "13". Example: B1368x4x4. Nuts, sleeve and insert can be ordered separately by catalog number.
- To order complete assembly with pipe sealant (Seal-A-Thread), add suffix "Z" to catalog number. Example: 1468x4x4Z (special order only).
- To order complete assembly with gauge ring, add suffix "K" to catalog number. Example: 1468x4x4K (special order only).

- NOTE**  
 Refer to current price list for availability of cataloged items. Quotations and delivery of non-stock items supplied on request. Configurations and dimensions subject to change without notice. Additional information can be found in SAE J246.

- Assembly Instructions**
  - Cut tubing to desired length.
  - Slide nut and then sleeve on tubing. Threaded end of nut "A" must face toward fitting body.
  - Insert tubing into the preassembled fitting. Be sure tubing is bottomed in fitting.
  - Tighten nut to required torque as indicated on chart. Another check on proper assembly is dimension A also noted on chart. A gauge ring also assures installation to specification. See page 98.

Tube Size	Torque	A Dimension
1/4	85 to 115 in. lbs.	.085/.105
3/8	12 to 17 ft. lbs.	.125/.145
1/2	25 to 33 ft. lbs.	.100/.120
5/8	26 to 35 ft. lbs.	.115/.135
3/4	38 to 50 ft. lbs.	.180/.200

**Disassembly:** Remove nut and pull tubing out of fitting body. Insert will remain in tubing.

**Reassembly:** Push tubing and insert into fitting body until it bottoms. Thread nut onto fitting body and torque as in Step 4.

**Label Set:** **FS-900** (adhesive)  
**CL-16-3** (non-adhesive)

BRASS

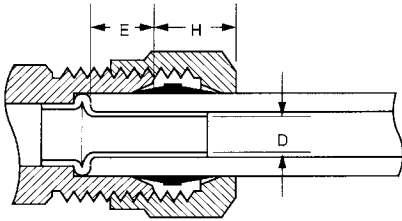

Tube O.D.	E Tube Stop	H*	D
1/4	.20	.32	.133
3/8	.26	.42	.215
1/2	.39	.45	.340
5/8	.39	.48	.398
3/4	.51	.50	.523

\*NOTE: H is hand tight

## Sleeve (Ref. SAE No. 100115)

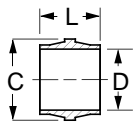

Tube O.D.	Catalog Number	Dia. C	D	L
1/4	1460x4	.359	.256	.30
3/8	1460x6	.479	.384	.39
1/2	1460x8	.625	.509	.43
5/8	1460x10	.745	.635	.48
3/4	1460x12	.922	.760	.53

## Nut (Ref. SAE No. 100110)

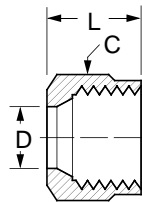
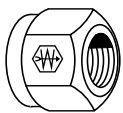

Tube O.D.	Catalog Number	Hex C	D	L
1/4	1461x4	9/16	.256	.45
3/8	1461x6	5/8	.384	.63
1/2	1461x8	13/16	.509	.72
5/8	1461x10	15/16	.634	.77
3/4	1461x12	1-1/8	.760	.81

## Union (Ref. SAE No. 100101BA)

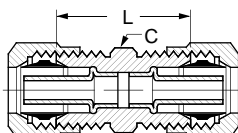
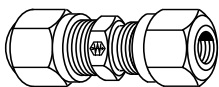

Tube O.D.	Catalog Number	Hex C	L
1/4	1462x4	7/16	.85
3/8	1462x6	9/16	1.10
1/2	1462x8	11/16	1.31
5/8	1462x10	13/16	1.43
3/4	1462x12	1	1.60



# Air Brake - Nylon Tubing

**Brass  
Fittings**

## Male Connector (Ref. SAE No. 100102BA)

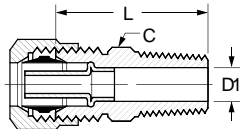
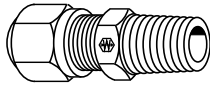

Tube O.D.	Male Pipe Thread	Catalog Number	Hex C	D1	L
1/4	1/16	1468x4x1	7/16	.125	.90
1/4	1/8	1468x4	7/16	.188	.88
1/4	1/4	1468x4x4	9/16	.188	1.09
1/4	3/8	1468x4x6	11/16	.188	1.12
3/8	1/8	1468x6x2	9/16	.188	1.02
3/8	1/4	1468x6	9/16	.312	1.20
3/8	3/8	1468x6x6	11/16	.312	1.23
3/8	1/2	1468x6x8	7/8	.312	1.42
1/2	1/4	1468x8x4	11/16	.312	1.32
1/2	3/8	1468x8	11/16	.406	1.32
1/2	1/2	1468x8x8	7/8	.406	1.51
1/2	3/4	1468x8x12	1-1/16	.406	1.57
5/8	3/8	1468x10x6	13/16	.406	1.38
5/8	1/2	1468x10	7/8	.531	1.57
5/8	3/4	1468x10x12	1-1/16	.750	1.63
3/4	1/2	1468x12	1	.531	1.67
3/4	3/4	1468x12x12	1-1/16	.660	1.70

## Female Connector (Ref. SAE No. 100103BA)

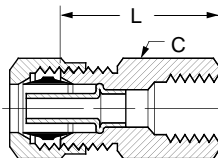
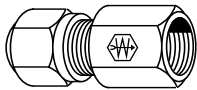

Tube O.D.	Fem. Pipe Thread	Catalog Number	Hex C	L
1/4	1/8	1466x4	9/16	.85
3/8	1/8	1466x6x2♦	9/16	1.01
3/8	1/4	1466x6	11/16	1.19
3/8	3/8	1466x6x6	7/8	1.19
1/2	3/8	1466x8	7/8	1.28
3/4	1/2	1466x12♦	1-1/16	1.58

## Bulkhead Union

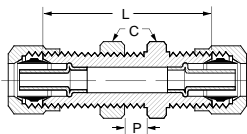
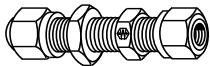

Tube O.D.	Catalog Number	Hex C	L	Max. P
1/4	1474x4	9/16	1.38	.25
3/8	1474x6	11/16	1.62	.25
1/2	1474x8♦	13/16	1.88	.25
5/8	1474x10♦	15/16	2.09	.25

## 45° Male Elbow (Ref. SAE No. 100302BA)

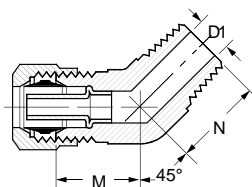
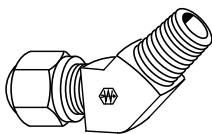

Tube O.D.	Male Pipe Thread	Catalog Number	D1	M	N
1/4	1/8	1480x4	.188	.50	.64
1/4	1/4	1480x4x4	.312	.61	.86
3/8	1/4	1480x6	.312	.72	.86
3/8	3/8	1480x6x6	.406	.76	.95
1/2	1/4	1480x8x4	.312	.85	.95
1/2	3/8	1480x8	.406	.85	.95
1/2	1/2	1480x8x8	.531	.88	1.17
5/8	1/2	1480x10	.531	.94	1.17

♦MTO - Made To Order

BRASS

**Union Elbow**  
(Ref. SAE No. 100201BA)

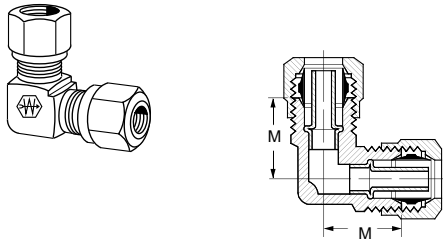

Tube O.D.	Catalog Number	M
3/8	1465x6♦	.80
1/2	1465x8♦	.94
5/8	1465x10♦	1.10

**90° Male Elbow**  
(Ref. SAE No. 100202BA)

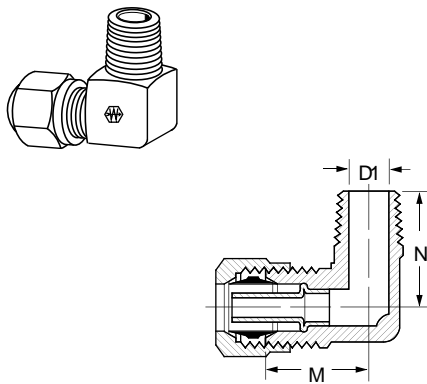

Tube O.D.	Male Pipe Thread	Catalog Number	D1	M	N
1/4	1/8	1469x4	.188	.63	.67
1/4	1/4	1469x4x4	.312	.69	.88
1/4	3/8	1469x4x6	.406	.74	.87
3/8	1/8	1469x6x2	.188	.73	.75
3/8	1/4	1469x6	.312	.80	.93
3/8	3/8	1469x6x6	.406	.85	.92
3/8	1/2	1469x6x8	.531	.95	1.11
1/2	1/4	1469x8x4	.312	.87	1.00
1/2	3/8	1469x8	.406	.94	1.00
1/2	1/2	1469x8x8	.531	1.04	1.19
5/8	3/8	1469x10x6	.406	1.01	1.06
5/8	1/2	1469x10	.531	1.10	1.25
5/8	3/4	1469x10x12	.656	1.21	1.25
3/4	3/8	1469x12x6♦	.406	1.10	1.15
3/4	1/2	1469x12	.531	1.20	1.34

**90° Male Elbow - Long**  
(Ref. SAE No. 100202BA)

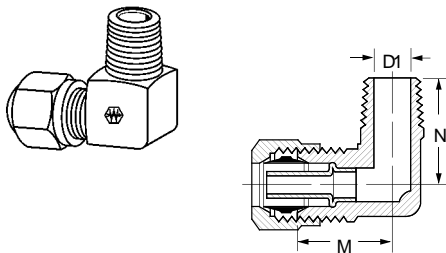

Tube O.D.	Male Pipe Thread	Catalog Number	D1	M	N
3/8	1/8	1469x6x2L♦	.188	.73	1.88
3/8	1/4	1469x6L	.312	.80	1.44
1/2	3/8	1469x8L	.406	.94	1.38
3/4	1/2	1469x12L♦	.531	1.20	1.81

**90° Female Elbow**  
(Ref. SAE No. 100203BA)

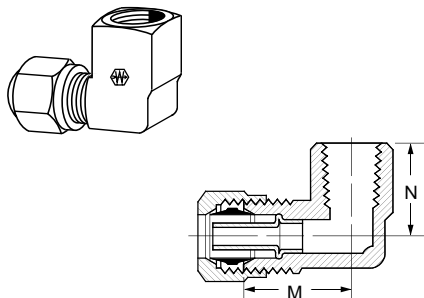

Tube O.D.	Fem. Pipe Thread	Catalog Number	M	N
1/4	1/8	1470x4♦	.70	.54
3/8	1/4	1470x6♦	.90	.78
3/8	3/8	1470x6x6♦	.95	.78
1/2	3/8	1470x8♦	1.04	.83

# Air Brake – Nylon Tubing

Brass  
Fittings

## Union Tee (Ref. SAE No. 100401BA)

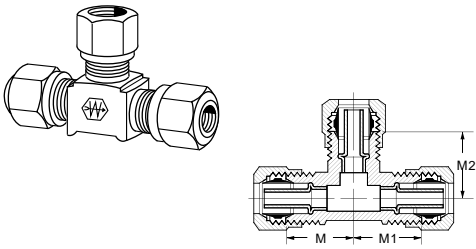

NOTE: Dimensions read left, right, center.

Tube O.D.	Catalog Number	M	M1	M2
1/4	1464x4	.63	.63	.63
1/4x3/8x3/8	1464x4x6x6♦	.70	.80	.80
3/8x3/8x1/4	1464x6x6x4	.72	.72	.69
3/8	1464x6	.80	.80	.80
3/8x3/8x1/2	1464x6x6x8♦	.86	.86	.86
1/2x3/8x1/2	1464x8x6x8♦	.94	.85	.94
1/2x1/2x3/8	1464x8x8x6	.86	.86	.85
1/2	1464x8	.94	.94	.94

## Male Branch Tee (Ref. SAE No. 100425BA)

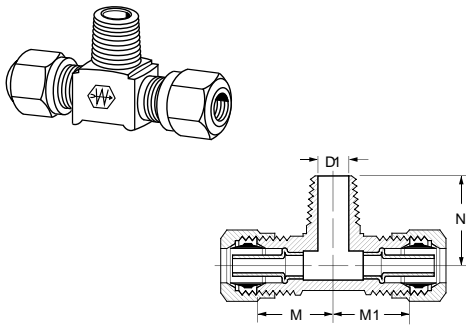

Tube O.D.	Male Pipe Thread	Catalog Number	D1	M	M1	N
1/4	1/8	1472x4	.188	.63	.63	.67
3/8x1/4	1/4	1472x6x4x4	.312	.80	.69	.93
3/8	1/8	1472x6x6x2♦	.188	.73	.73	.75
3/8	1/4	1472x6	.312	.80	.80	.93
3/8	3/8	1472x6x6x6	.406	.85	.85	.92
1/2x3/8	3/8	1472x8x6x6	.406	.94	.85	1.00
1/2	1/4	1472x8x8x4	.312	.87	.87	1.00
1/2	3/8	1472x8	.406	.94	.94	1.00
5/8	1/4	1472x10x10x4♦	.312	1.13	1.13	1.12

## Female Branch Tee

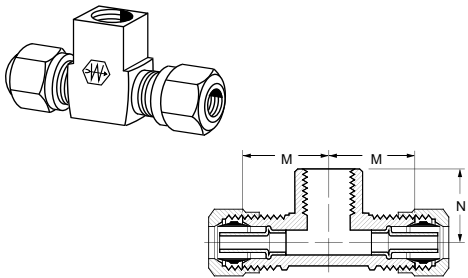

Tube O.D.	Fem. Pipe Thread	Catalog Number	M	N
3/8	1/4	1477x6	.90	.78
1/2	1/4	1477x8x8x4♦	.97	.83
5/8	1/4	1477x10x10x4	1.04	.89

## Male Run Tee (Ref. SAE No. 100424BA)

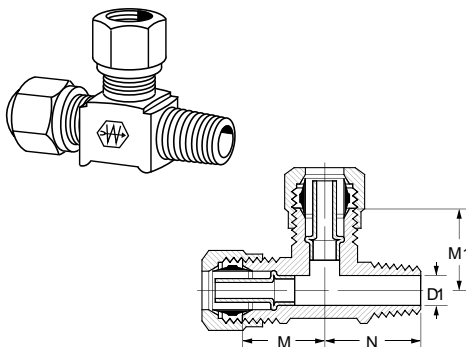

Tube O.D.	Male Pipe Thread	Catalog Number	D1	M	M1	N
1/4	1/8	1471x4	.188	.64	.64	.67
3/8x1/4	1/4	1471x6x4x4	.312	.72	.69	.88
3/8	1/4	1471x6	.312	.80	.80	.93
3/8	3/8	1471x6x6x6	.406	.85	.85	.92
1/2	3/8	1471x8♦	.406	.94	.94	1.10
5/8x1/4	1/2	1471x10x8x4♦	.531	1.10	1.10	1.25

♦MTO - Made To Order

BRASS

## Adapter Tee

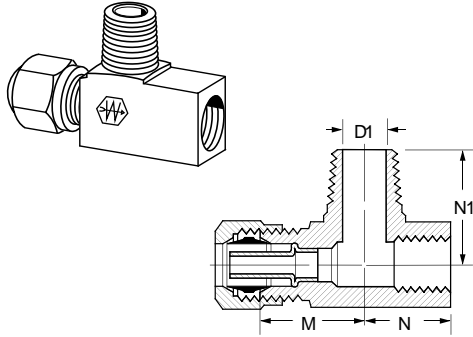

Tube O.D.	Fem. Pipe Thread	Male Pipe Thread	Catalog Number	D1	M	N	N1
3/8	1/4	1/4	1482x6x4x4♦	.312	.88	.75	.94
3/8	1/4	3/8	1482x6x4x6♦	.402	.94	.75	1.00
5/8	1/4	1/2	1482x10x4x8♦	.531	1.25	1.00	1.25

## Adapter Tee

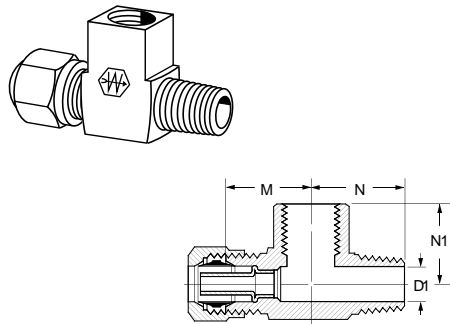

Tube O.D.	Male Pipe Thread	Fem. Pipe Thread	Catalog Number	D1	M	N	N1
3/8	3/8	1/4	1483x6x6x4♦	.406	.88	1.00	.95

## Insert

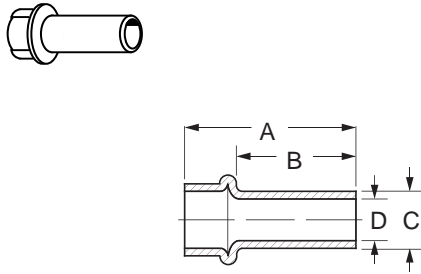

Tube O.D.	Catalog Number	A	B	C	D
1/4	1484x4	.64	.46	.163	.133
3/8	1484x6	.76	.58	.245	.215
1/2	1484x8	.94	.76	.370	.340
5/8	1484x10	1.06	.84	.434	.398
3/4	1484x12	1.21	1.00	.559	.523

## Gauge Ring

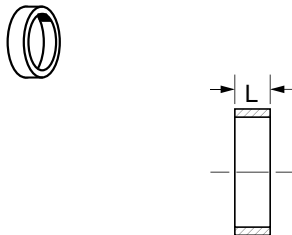

Tube O.D.	Catalog Number	L
1/4	1485x4	.085/.105
3/8	1485x6	.125/.145
1/2	1485x8	.100/.120
5/8	1485x10	.115/.135
3/4	1485x12	.180/.200

**NOTE:** Nut screwed to Gauge Ring assures installation to specifications.

# Air Brake - Copper Tubing

**Brass Fittings**

 Refer to safety information regarding tubing selection on page 1.

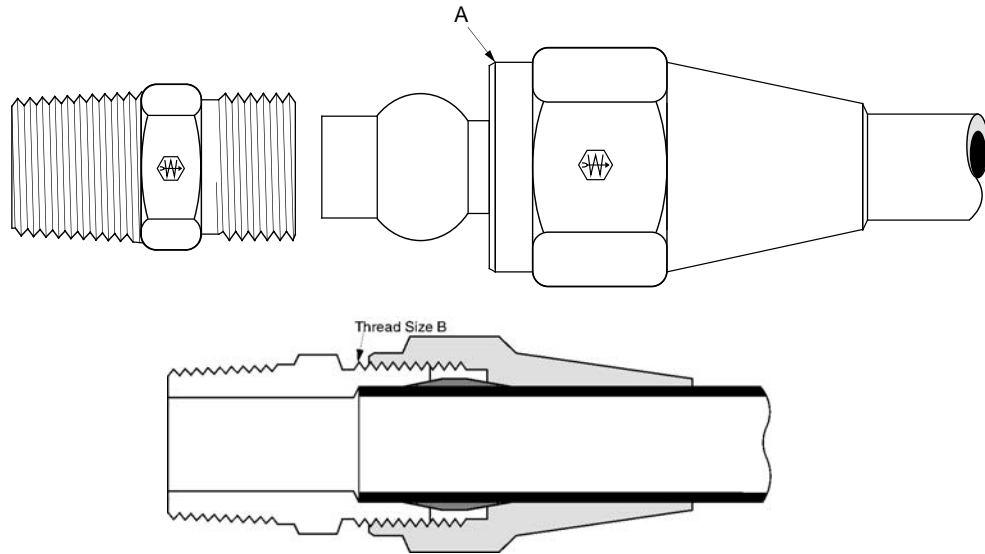

Tube O.D.	1/4	3/8	1/2	5/8	3/4	1
Thread Size-B	7/16-24	17/32-24	11/16-20	13/16-18	1-18	1-1/4-16

• **Typical Application**

Air brake systems.

• **Pressure**

Maximum operating pressure of 150 psi.

• **Vibration**

Fair resistance.

• **Temperature Range**

-65°F to +250°F (-53°C to +121°C) with copper tubing.

• **Material**

CA360 Brass.

• **Used With**

Copper tubing in air brake systems.

• **Advantages**

Easy to assemble (no flaring). May be used with nylon tubing by replacing long nut and spherical sleeve with insert, rigid sleeve and nut. See page 93 for details.

• **Conformance**

Meets specifications and standards of SAE and DOT.

• **How to Order**

For complete assemblies (body, nuts and sleeves), order by catalog number. Example: 1368x4. To order body only (less nut and sleeve), add prefix "B" to catalog number. Example: B1368x4. Nuts and sleeve can be ordered separately by catalog number.

To order complete assembly with pipe sealant (Seal-A-Thread), add suffix "Z" to catalog number. Example: 1368x4Z (special order only).

• **NOTE**

Refer to current price list for availability of cataloged items. Quotations and delivery of non-stock items supplied on request. Configurations and dimensions subject to change without notice. Additional information can be found in SAE J246.

• **Assembly Instructions**

1. Cut tubing to desired length. Make sure all burrs are removed and the ends are cut square.
2. Slide nut and then sleeve on tubing. Threaded end of nut "A" must face toward fitting body.
3. Insert tubing into fitting. Be sure tubing is bottomed on fitting shoulder.
4. Thread nut onto fitting body until it is hand tight.
5. From that point, tighten with a wrench the number of turns indicated in the chart below.

Tube Size	Additional Number of Turns from Hand Tight
1/4, 3/8	1-3/4
1/2, 5/8, 3/4	3-1/4

Label Set: **FS-800** (adhesive)  
**CL-491** (non-adhesive)

BRASS

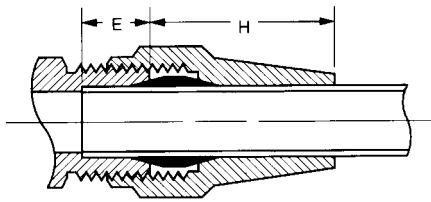

NOTE: H is hand tight.

Tube O.D.	E Tube Depth	H*
1/4	.25	.58
3/8	.31	.87
1/2	.44	.95
5/8	.44	1.05
3/4	.56	1.25

**Sleeve**  
(Ref. SAE No. 120115)

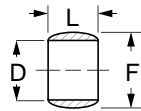

Tube O.D.	Catalog Number	D	F	L
1/4	1360x4	.255	.322	.250
3/8	1360x6	.382	.461	.313
1/2	1360x8	.507	.594	.375
5/8	1360x10	.632	.734	.438
3/4	1360x12	.758	.874	.500

**Nut**  
(Ref. SAE No. 120111)

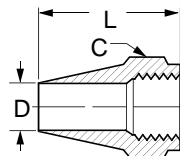
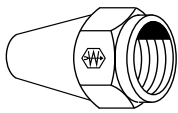

\*Compressor Nut with V groove Hex.

Tube O.D.	Catalog Number	Hex C	D	L
1/4	1361x4	9/16	.256	.75
3/8	1361x6	5/8	.384	1.13
1/2	1361x8	13/16	.509	1.25
5/8	1361x10	15/16	.634	1.38
5/8	1361x10V*+	1	.634	1.38
3/4	1361x12	1-1/8	.760	1.56

**Union**  
(Ref. SAE No. 120101BA)

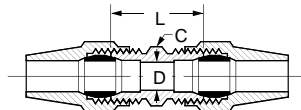

Tube O.D.	Catalog Number	Hex C	D	L
1/4	1362x4	7/16	.188	.85
3/8	1362x6	9/16	.312	1.10
1/2	1362x8	11/16	.406	1.31
5/8	1362x10	13/16	.531	1.43
3/4	1362x12	1	.656	1.60
1	1362x16	1-1/4	.875	1.78

**Male Connector**  
(Ref. SAE No. 120102BA)

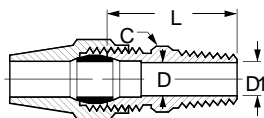

Tube O.D.	Male Pipe Thread	Catalog Number	Hex C	D	D1	L
1/4	1/8	1368x4	7/16	.188	.188	.88
1/4	1/4	1368x4x4	9/16	.188	.188	1.09
3/8	1/8	1368x6x2	9/16	.312	.188	1.02
3/8	1/4	1368x6	9/16	.312	.312	1.20
3/8	3/8	1368x6x6	11/16	.312	.406 opt.	1.23
3/8	1/2	1368x6x8	7/8	.312	.531 opt.	1.42
1/2	1/4	1368x8x4	11/16	.406	.312	1.32
1/2	3/8	1368x8	11/16	.406	.406	1.32
1/2	1/2	1368x8x8	7/8	.406	.531 opt.	1.51
5/8	3/8	1368x10x6	13/16	.531	.406	1.38
5/8	1/2	1368x10	7/8	.531	.531	1.57
3/4	1/2	1368x12	1	.656	.531	1.67
3/4	3/4	1368x12x12	1-1/16	.656	.719 opt.	1.70

# Air Brake - Copper Tubing

**Brass  
Fittings**

## Female Connector (Ref. SAE No. 120103BA)

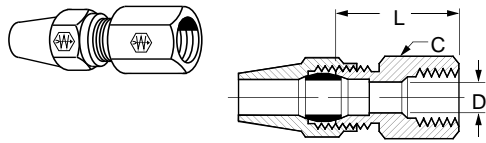

Tube O.D.	Fem. Pipe Thread	Catalog Number	Hex C	D	L
3/8	1/8	1366x6x2♦	9/16	.312	1.01
3/8	1/4	1366x6	11/16	.312	1.19
3/8	3/8	1366x6x6	7/8	.312	1.19
1/2	3/8	1366x8	7/8	.406	1.28

## 45° Male Elbow (Ref. SAE No. 120302BA)

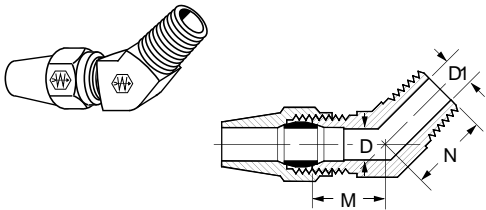

Tube O.D.	Male Pipe Thread	Catalog Number	D	D1	M	N
3/8	1/4	1380x6	.312	.312	.72	.86
3/8	3/8	1380x6x6	.312	.406	.76	.95
1/2	3/8	1380x8	.406	.406	.85	.95
5/8	1/2	1380x10	.531	.531	.94	1.17

## Union Elbow (Ref. SAE No. 120201BA)

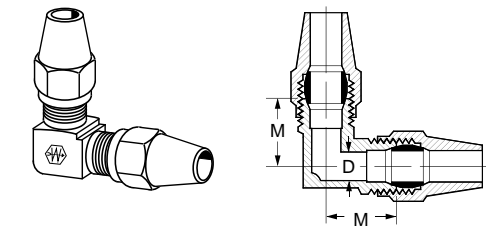

Tube O.D.	Catalog Number	M	D
3/8	1365x6♦	.80	.312
1/2	1365x8♦	.94	.406
5/8	1365x10♦	1.10	.531

## 90° Male Elbow (Ref. SAE No. 120202BA)

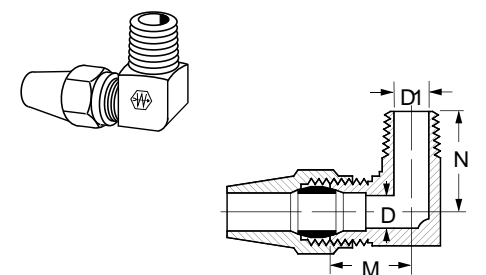

Tube O.D.	Male Pipe Thread	Catalog Number	D	D1	M	N
1/4	1/8	1369x4	.188	.188	.63	.67
1/4	1/4	1369x4x4	.188	.312	.69	.88
3/8	1/8	1369x6x2	.312	.188	.73	.75
3/8	1/4	1369x6	.312	.312	.80	.93
3/8	3/8	1369x6x6	.312	.406	.85	.92
3/8	1/2	1369x6x8	.312	.531	.95	1.11
1/2	1/4	1369x8x4	.406	.312	.87	1.00
1/2	3/8	1369x8	.406	.406	.94	1.00
1/2	1/2	1369x8x8	.406	.531	1.04	1.19
5/8	3/8	1369x10x6	.531	.406	1.01	1.06
5/8	1/2	1369x10	.531	.531	1.10	1.25

## 90° Male Elbow - Long

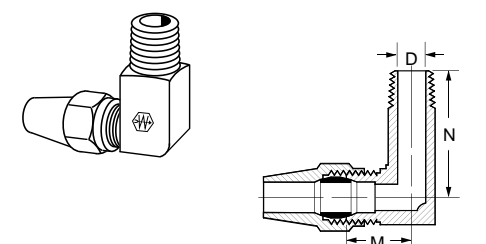

Tube O.D.	Male Pipe Thread	Catalog Number	D	M	N
3/8	1/8	1369x6x2L♦	.188	.75	1.88
3/8	1/4	1369x6L	.312	.81	1.44
1/2	3/8	1369x8L	.406	1.25	1.38
3/4	1/2	1369x12L♦	.531	1.31	1.81

♦MTO - Made To Order

BRASS

**90° Female Elbow**  
(Ref. SAE No. 120203BA)

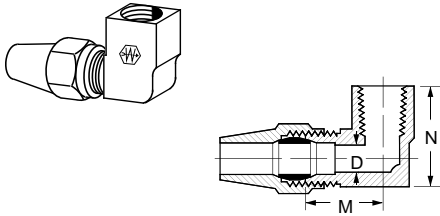

Tube O.D.	Fem. Pipe Thread	Catalog Number	D	M	N
3/8	1/4	1370x6♦	.312	.90	.78
3/8	3/8	1370x6x6♦	.312	.95	.78
1/2	3/8	1370x8♦	.406	1.04	.83

**Union Tee**  
(Ref. SAE No. 120401BA)

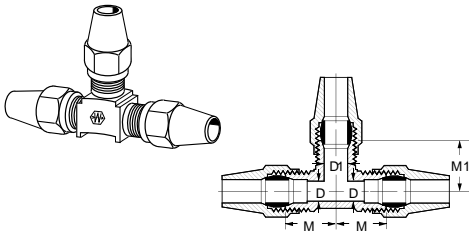

Tube O.D.	Catalog Number	M	M1	D	D1
3/8	1364x6	.80	.80	.312	.312
3/8x3/8x1/2	1364x6x6x8♦	.86	.86	.312	.406
1/2	1364x8	.94	.94	.406	.406

**Male Run Tee**  
(Ref. SAE No. 120424BA)

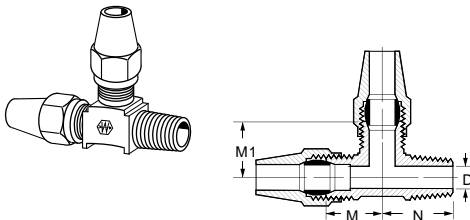

Tube O.D.	Male Pipe Thread	Catalog Number	D	M	M1	N
3/8	1/4	1371x6	.312	.80	.80	.93
3/8	3/8	1371x6x6x6	.406	.85	.85	.92
1/2	3/8	1371x8♦	.406	.94	.94	1.00

**Male Branch Tee**  
(Ref. SAE No. 120425BA)

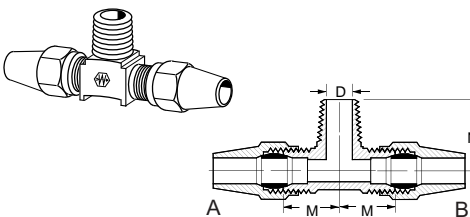

Tube O.D.	Tube O.D. A	Male Pipe Thread B	Catalog Number	D	M	N
3/8	3/8	1/8	1372x6x6x2♦	.188	.73	.75
3/8	3/8	1/4	1372x6	.312	.80	.93
3/8	3/8	3/8	1372x6x6x6	.406	.85	.92
1/2	1/2	3/8	1372x8	.406	.94	1.00
5/8	1/2	1/2	1372x10x8x8♦	.530	1.120	1.060

**Adapter Tee**

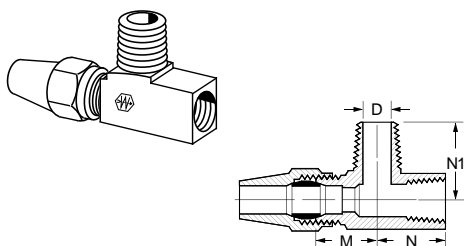

Tube O.D.	M&F Pipe Thread	Catalog Number	D	M	N	N1
3/8	1/4	1382x6x4x4♦	.312	.88	.75	.94

♦MTO - Made To Order



# Air Brake – Copper Tubing

**Brass  
Fittings**

## Bulkhead Coupling (Brass)

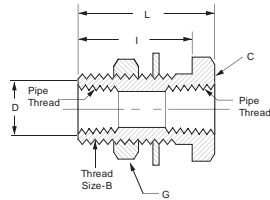
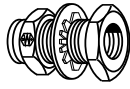

Fem. Pipe Thread	Catalog Thread	Thread Size B	Hex C	Hex C1	D	I	L
1/4	<a href="#">1344</a>	3/4-16	1	15/16	.422	1.25	1.50
1/4	<a href="#">1345</a>	3/4-16	1	15/16	.422	.69	.94
3/8	<a href="#">1346</a>	1-14	1-1/8	1-3/8	.563	1.06	1.31
1/2	<a href="#">1351</a>	1-1/8-14	1-1/4	1-3/8	.703	1.19	1.50

## Bulkhead Coupling (Brass)

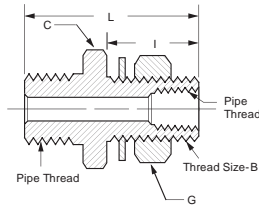

Male Pipe Thread	Fem. Pipe Thread	Catalog Number	Thread Size B	Hex C	Hex C1	D	I	L
1/2	1/4	<a href="#">1340</a>	3/4-16	1-1/4	15/16	.312	1.13	2.16
1/2	1/4	<a href="#">1341</a>	3/4-16	1-1/4	15/16	.312	1.53	2.53

## Bulkhead Coupling (Brass)

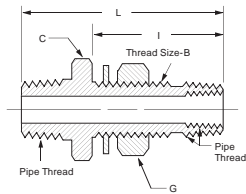
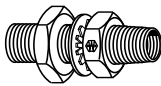

Male Pipe Thread	Fem. Pipe Thread	Catalog Number	Thread Size B	Hex C	Hex C1	D	I	L
1/2	1/4	<a href="#">1342</a>	1-14	1-1/4	1-3/8	.375	1.88	2.94
1/2	1/4	<a href="#">1343</a>	1-14	1-1/4	1-3/8	.375	2.88	3.94

## Draincock

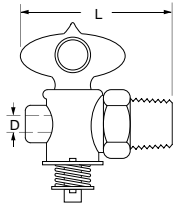
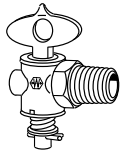

Male Pipe Thread	Catalog Number	D	L
1/4	<a href="#">W15310</a>	.188	1.56

## Shut Off Valve

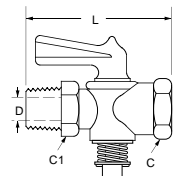
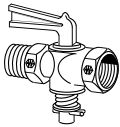

Rating: 125 psi with one 1/4" bubble in 5 seconds permissible key leakage.

Male Pipe Thread	Fem. Pipe Thread	Catalog Number	Hex C	Hex C1	D	L
1/4	1/4	<a href="#">W20332</a>	5/8	3/4	.218	1.81

## External Seat Draincock

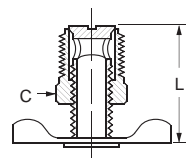

Male Pipe Thread	Catalog Number	Hex C	L
1/4	<a href="#">145</a>	9/16	1.00

BRASS

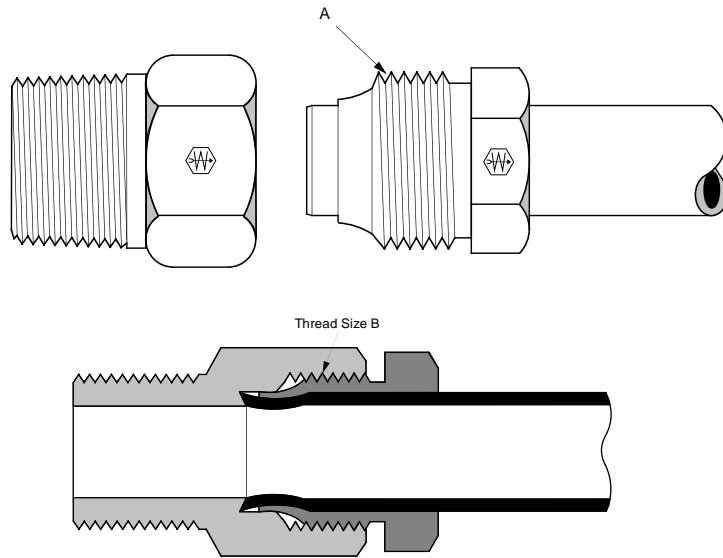

<b>Tube O.D.</b>	1/8	3/16	1/4	5/16	3/8
<b>Thread Size-B</b>	5/16-24	3/8-24	7/16-24	1/2-20	9/16-20

- **Typical Application**  
Oil, air, water and lubrication systems.
- **Pressure**  
Operating pressure of 500 psi for 1/8" to 1/4" sizes, 250 psi for 5/16" and 3/8" sizes.
- **Vibration**  
Fair resistance.
- **Temperature Range**  
-65°F to +250°F (-53°C to +121°C) range at maximum operating pressures.
- **Material**  
CA360 Brass.
- **Used With**  
Aluminum and copper tubing. Not recommended for steel tubing.
- **Advantages**  
Easy to assemble, no flaring. Two (2) piece construction.
- **Conformance**  
Meets ASA and ASME specifications.
- **How to Order**  
Order individually by catalog number.
- **NOTE**  
Refer to current price list for availability of cataloged items. Quotations and delivery of non-stock items supplied on request. Configurations and dimensions subject to change without notice.
- **Assembly Instructions**
  1. Cut tubing to desired length.
  2. Slide nut on end of tube. Threaded end "A" of nut must face toward fitting.
  3. Insert tube into fitting body. Be sure tube is bottomed on fitting shoulder.
  4. Lubricate threads and assemble nut to fitting body.
  5. Tighten nut, hand tight. From hand tight, tighten with a wrench 1-1/2 additional turns to form proper seal.

# Threaded Sleeve

**Brass  
Fittings**

## Nut

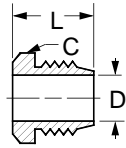
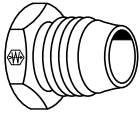

Tube O.D.	Catalog Number	Hex C	D	L
1/8	6100x2	3/8	.130	.50
3/16	6100x3	7/16	.193	.53
1/4	6100x4	1/2	.255	.56
5/16	6100x5♦	9/16	.318	.61
3/8	6100x6♦	5/8	.380	.61

## Male Connector

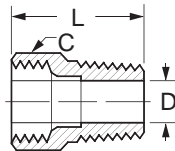
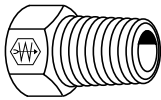

\*Thread Size 1/4-28 Tapered Male Thread

Tube O.D.	Male Pipe Thread	Catalog Number	Hex C	D	L
1/8	1/8	6200x2	7/16	.078	.62
1/8	*	6200x2x21	7/16	.080	.62
3/16	1/8	6200x3	7/16	.141	.69
1/4	1/8	6200x4	1/2	.188	.75
5/16	1/8	6200x5♦	9/16	.219	.89
3/8	1/4	6200x6♦	5/8	.312	.97

## Union

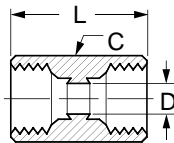
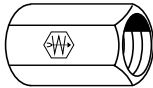

Tube O.D.	Catalog Number	Hex C	D	L
1/4	6300x4♦	1/2	.187	1.00
5/16	6300x5♦	9/16	.218	1.00

## Male Elbow

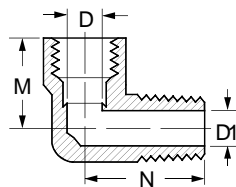
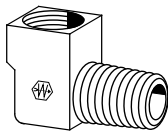

\*Thread Size 1/4-28 Tapered Male Thread

Tube O.D.	Male Pipe Thread	Catalog Number	D	D1	M	N
1/8	1/8	6400x2	.073	.125	.50	.66
1/8	*	6400x2x21	.078	.080	.50	.52
3/16	1/8	6400x3	.141	.156	.56	.62
1/4	1/8	6400x4	.188	.188	.52	.62
5/16	1/8	6400x5♦	.219	.219	.56	.70
3/8	1/4	6400x6♦	.312	.312	.72	.97

## Adapter Tee

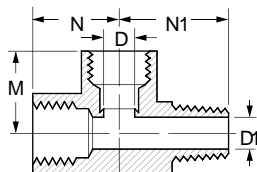
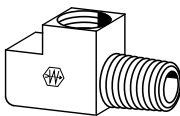

Tube O.D.	M & F Pipe Thread	Catalog Number	D	D1	M	N	N1
3/16	1/8	6550x3♦	.141	.188	.56	.66	.62

♦MTO - Made To Order

BRASS

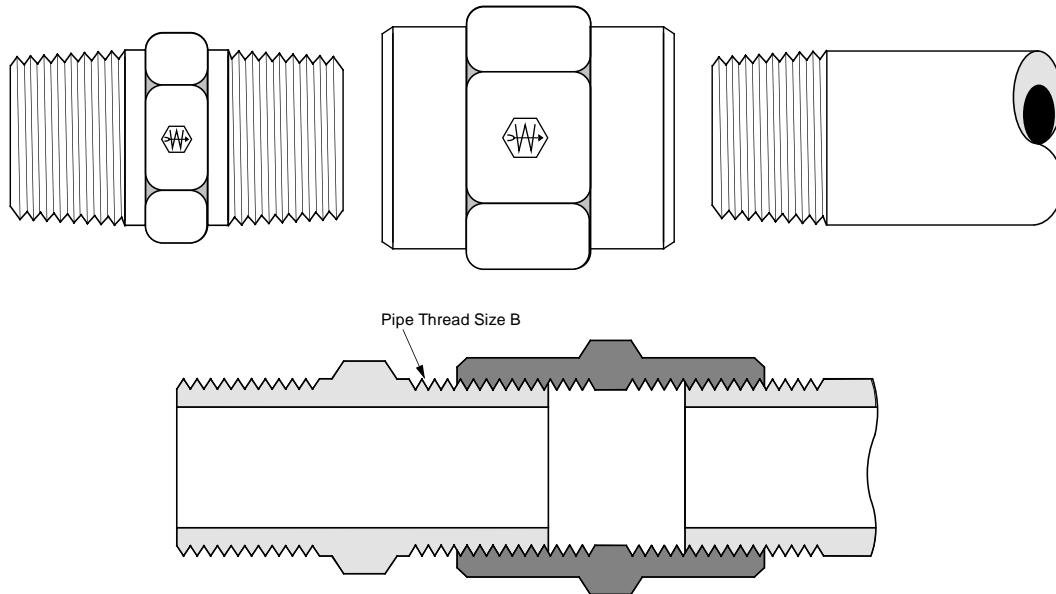

<b>Pipe Size</b>	1/16	1/8	1/4	3/8	1/2	3/4
<b>Thread Size-B</b>	1/16-27	1/8-27	1/4-18	3/8-18	1/2-14	3/4-14

- **Typical Application**  
Grease, fuels, LP and natural gas (available on special order), refrigeration, instrumentation and hydraulic systems.
- **Pressure**  
Operating pressure up to 1200 psi.
- **Vibration**  
Fair resistance.
- **Temperature Range**  
-65°F to +250°F (-53°C to +121°C).
- **Material**  
CA360 Brass.
- **Used With**  
Brass, bronze and iron pipe.
- **Advantages**  
Dryseal pipe threads. Large range of sizes and configurations
- **Conformance**  
Listed by Underwriters Laboratories (available on special order) for fuel equipment, refrigeration and gas. Meets specifications and standards of ASA, ASME and SAE.
- **How to Order**  
Order individually by catalog number. Example: 3325x4. To order with pipe sealant (Seal-A-Thread), add a "Z" suffix to the catalog number. (Special order only). Example: 3325x4Z.
- **NOTE**  
Refer to current price list for availability of cataloged items. Quotations and delivery of non-stock items supplied on request. Configurations and dimensions subject to change without notice. Additional information can be found in SAE J530 Automotive Pipe Fittings and SAE J531 Drain Plugs.
- **Assembly Instructions**
  1. Tighten approximately 2-1/2 turns past hand tight.
  2. Fittings with Seal-A-Thread tighten two turns past hand tight. Brittle materials require special cautions.
- **Label Set:** **W-8022** (adhesive)  
**CL-490** (non-adhesive)

# Pipe

## Brass Fittings

### Cap

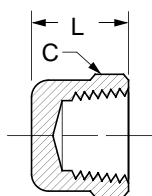

\*PTF Short Thread

Fem. Pipe Thread	Catalog Number	Hex C	L
1/8*	3129x2	9/16	.50
1/4*	3129x4	11/16	.59
3/8*	3129x6	13/16	.68

### Slotted Plug

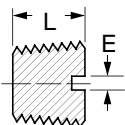

\*PTF Short Thread

Male Pipe Thread	Catalog Number	E	L
1/8*	3150x2	.05	.28
1/4*	3150x4	.08	.42
3/8*	3150x6	.09	.43

### Square Head Plug

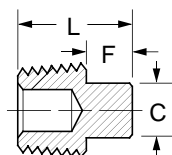
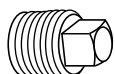

\*PTF Short Thread

Male Pipe Thread	Catalog Number	Square C	F	L
1/8*	3151x2	.28	.24	.58
1/4*	3151x4	.37	.29	.74
3/8*	3151x6	.43	.32	.82
1/2*	3151x8	.56	.39	.99
3/4*	3151x12	.62	.43	1.12

### Hex Head Plug

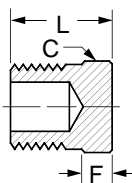
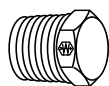

\* PTF Short Thread  
\*\* PTF Special Short Thread

Male Pipe Thread	Catalog Number	Hex C	F	L
1/16	3152x1♦	3/8	.18	.56
1/8*	3152x2	7/16	.19	.57
1/4*	3152x4	9/16	.18	.62
3/8*	3152x6	11/16	.22	.72
1/2*	3152x8	7/8	.22	.78
3/4**	3152x12	1-1/16	.25	.88

### Hex Socket Plug

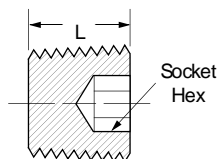

Male Pipe Thread	Catalog Number	Socket Hex	L
1/16	3153x1♦	5/32	.260
1/8	3153x2	3/16	.270
1/4	3153x4♦	1/4	.410
3/8	3153x6♦	5/16	.410
1/2	3153x8♦	3/8	.540

### Adapter (Ref. SAE No. 130139)

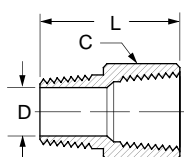
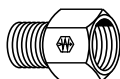

Fem. Pipe Thread	Male Pipe Thread	Catalog Number	Hex C	D	L
1/8	1/16	3200x2x1♦	1/2	.125	.88
1/8	1/8	3200x2	9/16	.219	.88
1/4	1/8	3200x4x2	3/4	.219	1.06
1/4	1/4	3200x4	3/4	.312	1.25
3/8	1/4	3200x6x4	7/8	.312	1.25
3/8	3/8	3200x6	7/8	.438	1.25
1/2	3/8	3200x8x6	1-1/16	.438	1.47
3/4	3/8	3200x12x6	1-1/4	.438	1.59
3/4	1/2	3200x12x8	1-1/4	.562	1.69

♦MTO - Made To Order

BRASS

## Bushing (Ref. SAE No. 130140)

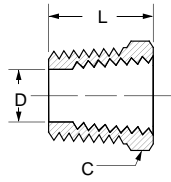

\*PTF Short Thread  
\*\*Optional Counterbore

Male Pipe Thread	Fem. Pipe Thread	Catalog Number	Hex C	DL	L
1/4*	1/8	3220x4x2	5/8	.339	.59
3/8	1/8	3220x6x2	11/16	.328	.75
3/8*	1/4	3220x6x4	11/16	.438	.69
1/2*	1/8	3220x8x2	7/8	.530**	.75
1/2*	1/4	3220x8x4	7/8	.438**	.75
1/2*	3/8	3220x8x6	7/8	.562	.75
3/4*	3/8	3220x12x6	1-1/8	.562	.88
3/4*	1/2	3220x12x8	1-1/8	.703	.88

## Union

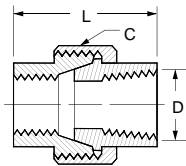
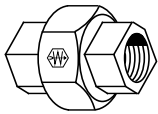

\*PTF Short Thread

Fem. Pipe Thread	Catalog Number	Hex C	D	L
1/8*	3250x2*	7/8	.339	.97
1/4*	3250x4	1-1/16	.438	1.31
3/8	3250x6*	1-5/16	.560	1.66
1/2	3250x8	1-9/16	.703	1.81

## Coupling (Ref. SAE No. 130138)

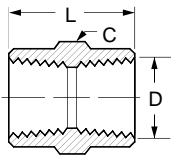
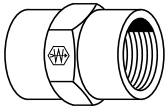

Fem. Pipe Thread	Catalog Number	Hex C	D	L
1/16	3300x1	7/16	.339	.75
1/8	3300x2	9/16	.339	.75
1/4	3300x4	3/4	.438	1.12
3/8	3300x6	7/8	.578	1.12
1/2	3300x8	1-1/16	.703	1.50
3/4	3300x12	1-1/4	.906	1.53

## Reducer Coupling (Ref. SAE No. 130138)

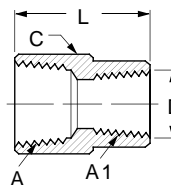
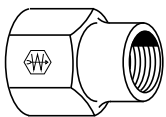

Fem. Pipe Thread A	Fem. Pipe Thread A1	Catalog Number	Hex C	D	L
1/4	1/8	3300x4x2	3/4	.339	.96
3/8	1/8	3300x6x2	7/8	.339	.94
3/8	1/4	3300x6x4	7/8	.438	1.16
1/2	3/8	3300x8x6	1-1/16	.562	1.38

## Hex Nipple (Ref. SAE No. 130137)

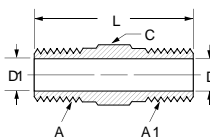

\*Optional Counterbore .312

Male Pipe Thread A	Male Pipe Thread A1	Catalog Number	Hex C	D	D1	L
1/16	1/16	3325x1	3/8	.125	.125	.978
1/8	1/8	3325x2	7/16	.219	.219	.97
1/8	1/16	3325x2x1	7/16	.230	.156	.955
1/4	1/8	3325x4x2	9/16	.219	.219*	1.19
1/4	1/4	3325x4	9/16	.312	.312	1.38
3/8	1/8	3325x6x2	11/16	.219	.438	1.22
3/8	1/4	3325x6x4	11/16	.312	.438	1.41
3/8	3/8	3325x6	11/16	.438	.438	1.41
1/2	1/2	3325x8	7/8	.562	.562	1.81
3/4	3/4	3325x12	1-1/16	.750	.750	1.94

### Close Nipple

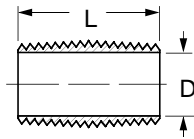
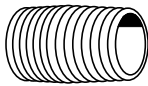

Male Pipe Thread	Catalog Number	D	L
1/8	3326x2	.281	.75
1/4	3326x4	.375	.88
3/8	3326x6	.500	1.00
1/2	3326x8	.625	1.12
3/4	3326x12	.750	1.38

### Long Nipple

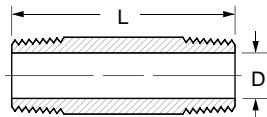
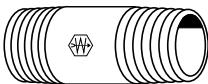

Male Pipe Thread	Catalog Number	D	L
1/8	3327x2	.281	1.50
1/8	3328x2	.281	2.00
1/8	3329x2	.281	2.50
1/8	3330x2	.281	3.00
1/8	3331x2♦	.281	3.50
1/4	3327x4	.375	1.50
1/4	3328x4	.375	2.00
1/4	3329x4	.375	2.50
1/4	3330x4	.375	3.00
1/4	3331x4	.375	3.50
3/8	3327x6	.480	1.50
3/8	3328x6	.490	2.00
3/8	3329x6	.480	2.50
3/8	3330x6	.480	3.00
3/8	3331x6♦	.480	3.50
1/2	3328x8	.625	2.00
1/2	3329x8	.625	2.50
1/2	3330x8	.625	3.00
3/4	3328x12♦	.750	2.00
3/4	3329x12	.750	2.50

### Bulkhead Coupling (Brass)

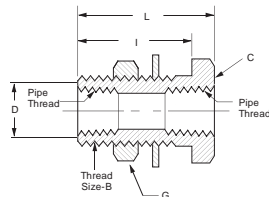
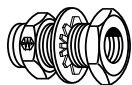

Fem. Pipe Thread	Catalog Thread	Thread Size B	Hex C	Hex C1	D	I	L
1/4	1344	3/4-16	1	15/16	.422	1.25	1.50
1/4	1345	3/4-16	1	15/16	.422	.69	.94
3/8	1346	1-14	1-1/8	1-3/8	.563	1.06	1.31
1/2	1351	1-1/8-14	1-1/4	1-3/8	.703	1.19	1.50

♦MTO - Made To Order

**Bulkhead Coupling (Brass)**

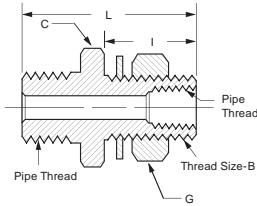
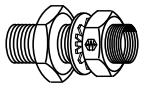

Male Pipe Thread	Fem. Pipe Thread	Catalog Number	Thread Size B	Hex C	Hex C1	D	I	L
1/2	1/4	1340	3/4-16	1-1/4	15/16	.312	1.13	2.16
1/2	1/4	1341	3/4-16	1-1/4	15/16	.312	1.53	2.53

**Bulkhead Coupling (Brass)**

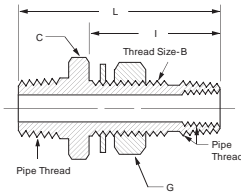
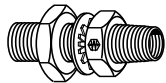

Male Pipe Thread	Fem. Pipe Thread	Catalog Number	Thread Size B	Hex C	Hex C1	D	I	L
1/2	1/4	1342	1-14	1-1/4	1-3/8	.375	1.88	2.94
1/2	1/4	1343	1-14	1-1/4	1-3/8	.375	2.88	3.94

**45° Street Elbow  
(Ref. SAE No. 130339)**

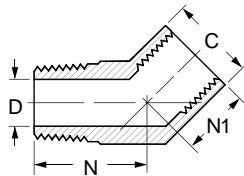

Male Pipe Thread	Fem. Pipe Thread	Catalog Number	C	D	N	N1
1/8	1/8	3350x2	9/16	.219	.50	.38
1/4	1/4	3350x4	11/16	.312	.74	.56
3/8	3/8	3350x6	13/16	.438	.78	.56
1/2	1/2	3350x8	1	.562	1.00	.76
3/4	3/4	3350x12	1-1/14	.750	1.06	.75

**Street Elbow  
(Ref. SAE No. 130239)**

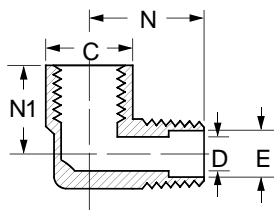
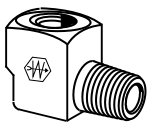

Fem. Pipe Thread	Male Pipe Thread	Catalog Number	C	D	E	N	N1
1/16	1/16	3400x1*	7/16	.141	.141	.590	.450
1/8	1/8	3400x2	9/16	.219	.25	.66	.47
1/8*	1/8**	3400x2W	1/2	.188	.25	.57	.34
1/4	1/8	3400x4x2	11/16	.219	-	.72	.53
1/4*	1/4**	3400x4W	11/16	.266	.36	.78	.45
1/4	1/4	3400x4	11/16	.312	-	.91	.72
3/8	3/8	3400x6	13/16	.438	-	.97	.78
1/2	1/2	3400x8	1	.562	-	1.25	1.03
3/4	3/4	3400x12	1-1/4	.750	-	1.38	1.12

\* PTF Short Thread  
\*\* PTF Special Short Thread



### Elbow (Ref. SAE No. 130238)

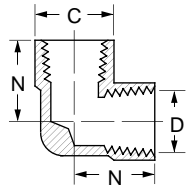
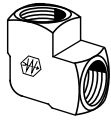

Fem. Pipe Thread	Catalog Number	C	D	N
1/8	3500x2	9/16	.339	.55
1/4	3500x4	11/16	.438	.78
3/8	3500x6	13/16	.562	.84
1/2	3500x8	1	.703	1.09
3/4	3500x12	1-1/4	.906	1.16

### Male Branch Tee (Ref. SAE No. 130425)

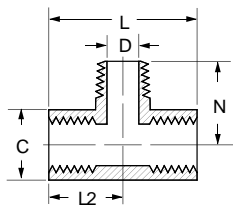
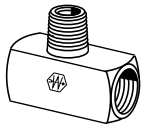

Fem. Pipe Thread	Male Pipe Thread	Catalog Number	C	D	L	L2	N
1/8	1/8	3600x2	9/16	.219	1.10	.55	.66
1/4	1/4	3600x4	11/16	.312	1.56	.78	.91
3/8	3/8	3600x6	13/16	.438	1.68	.84	.97
1/2	1/2	3600x8	1	.562	2.18	1.09	1.25
3/4	3/4	3600x12	1-1/4	.750	2.31	1.16	1.38

### Tee (Ref. SAE No. 130438)

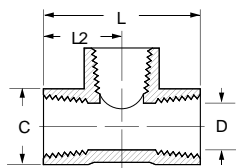
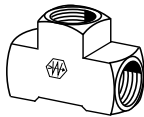

Fem. Pipe Thread	Catalog Number	C	D	L	L2
1/16	3700x1♦	7/16	.141	.96	.48
1/8	3700x2	9/16	.339	1.10	.55
1/4	3700x4	11/16	.438	1.56	.78
3/8	3700x6	13/16	.562	1.68	.84
1/2	3700x8	1	.703	2.18	1.09
3/4	3700x12	1-1/4	.906	2.32	1.16

### Street Tee (Ref. SAE No. 130424)

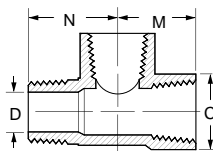
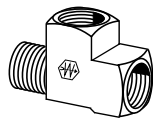

Fem. Pipe Thread	Male Pipe Thread	Catalog Number	C	D	M	N
1/8	1/8	3750x2	9/16	.219	.55	.66
1/4	1/4	3750x4	11/16	.312	.78	.90
3/8	3/8	3750x6	13/16	.438	.84	.97
1/2	1/2	3750x8	1	.562	1.09	1.25
3/4	3/4	3750x12	1-1/4	.750	1.16	1.38

### Cross

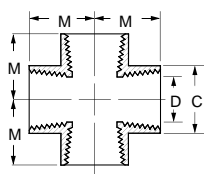
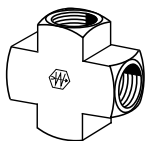

Fem. Pipe Thread	Catalog Number	C	D	M
1/8	3950x2	1/2	.339	.50
1/4	3950x4	11/16	.438	.75
3/8	3950x6	7/8	.562	.81
1/2	3950x8	1	.703	1.09
3/4	3950x12♦	1-1/4	.906	1.16

♦MTO - Made To Order

 Refer to safety information regarding tubing selection on page 1.

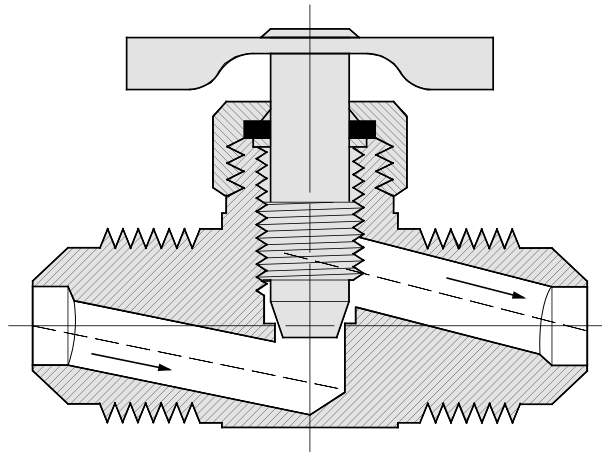

- **Typical Application**  
Instrumentation, hydraulic and pneumatic systems.
- **Pressure**  
150 psi maximum. (Does not include plastic tubing.)
- **Temperature Range**  
-65°F to +250°F (-53°C to +121°C) with metal tubing. For valves using compatible tubing, refer to the tubing temperature range.
- **Material**  
Brass bodies, steel handles except where noted. POLYLINE® valves have brass bodies and brass handles.
- **Used With**  
Copper, aluminum, steel and plastic tubing where applicable. When using POLYLINE® valves, use aluminum and copper tubing with brass sleeve only. Plastic tubing may be used with either brass or plastic sleeve.
- **Advantages**  
Metal-to-metal seat, with fine thread screwdown, enables valves to seat positively, adjust easily and hold to any amount of flow up to capacity of the valve.
- **Conformance**  
Designed for automotive and industrial use. Not intended for natural gas, LPG, nuclear or aircraft applications.
- **How to Order**  
Order valve body, nuts and sleeves by catalog number. Order valve with SELFALIGN® nuts and sleeves by adding suffix "S". Example: A6763 becomes A6763S. Order valves less nuts and sleeves by adding prefix "B". Example: A6763 becomes B6763.
- **Assembly Instructions**  
1. Install with the pressure against the seat. Inspection of a straight valve discloses one opening to be higher than the other. Pressure should always be directed against the seat in angle valves, not the stem threads.

# Needle Valves

**Brass  
Fittings**

## Compression Double

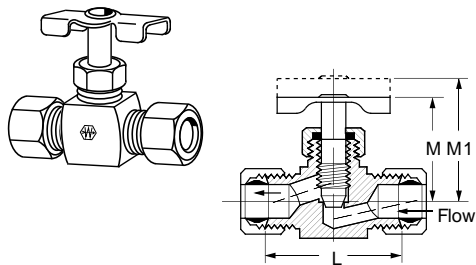

"S" suffix designates Selfalign® with nuts and sleeves.

Tube O.D.	Catalog Number	L	M	M1
3/16	A6763	1.06	.88	1.03
3/16	A6763S	1.06	.88	1.03
1/4	A6765	1.13	.88	1.03
1/4	A6765S	1.13	.88	1.03
5/16	A6770	1.13	.88	1.03
3/8	A6775	1.50	1.13	1.31
3/8	A6775S	1.50	1.13	1.31

## Compression Straightway

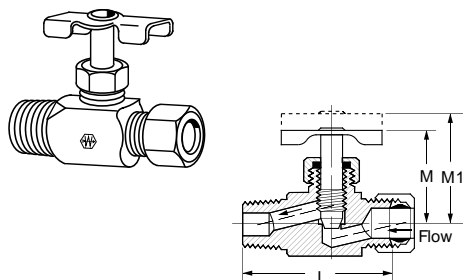

"S" suffix designates Selfalign® with nuts and sleeves.

Tube O.D.	Male Pipe Thread	Catalog Number	L	M	M1
3/16	1/8	A6690	1.16	.88	1.03
3/16	1/8	A6690S	1.16	.88	1.03
1/4	1/8	A690	1.19	.88	1.03
1/4	1/8	A690S	1.19	.88	1.03
5/16	1/8	A660	1.18	.90	1.05
5/16	1/4	A6755	1.28	.91	1.09
5/16	1/4	A6755S	1.28	.91	1.09
3/8	1/4	A6760	1.82	1.31	1.46
3/8	1/4	A6760S	1.82	1.31	1.46

## Compression Angle

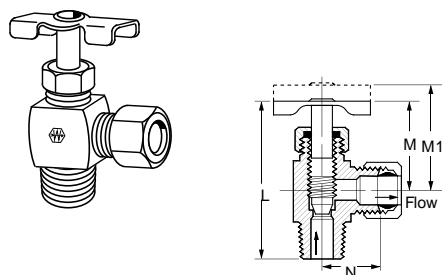

"S" suffix designates Selfalign® with nuts and sleeves.

Tube O.D.	Male Pipe Thread	Catalog Number	L	M	M1	N
3/16	1/8	A6845	1.50	.82	1.07	.50
3/16	1/8	A6845S	1.50	.82	1.07	.50
1/4	1/8	A555	1.53	.83	1.05	.53
1/4	1/8	A555S	1.53	.83	1.05	.53
5/16	1/8	A655	1.56	.84	1.09	.52
5/16	1/8	A655S	1.56	.84	1.09	.52
5/16	1/4	A6855	1.73	.92	1.28	.69
5/16	1/4	A6855S	1.73	.92	1.28	.69
3/8	1/4	A6860	1.64	.83	1.28	.78
3/8	1/4	A6860S	1.64	.83	1.28	.78

## Inverted Straightway

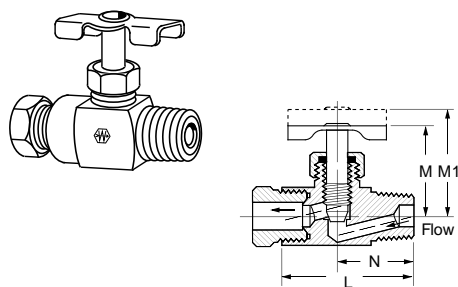

For replacement nut use **105x4**. See page 37.  
"B" prefix designates less inverted nut.

Tube O.D.	Male Pipe Thread	Catalog Number	L	M	M1	N
1/4	1/8	A735	1.38	.84	1.01	.69
1/4	1/8	B735	1.38	.84	1.01	.69

BRASS

## Male Pipe Double

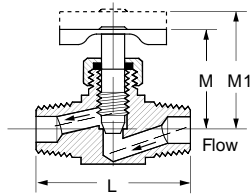
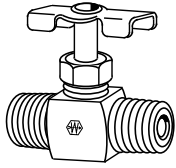

Male Pipe Thread	Catalog Number	L	M	M1
1/8	6810	1.38	.66	.80
1/4	6815	1.62	1.08	1.23

## Male to Female Pipe

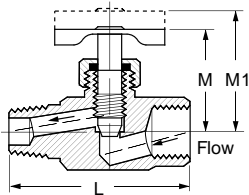
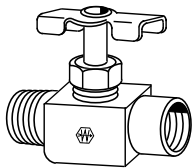

Fem. Pipe Thread	Male Pipe Thread	Catalog Number	L	M	M1
1/8	1/8	6820	1.18	.88	1.03
1/4	1/4	6825	1.88	1.09	1.24

## Female Pipe

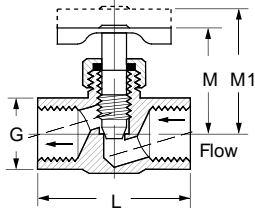
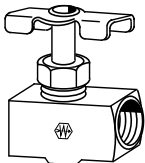

Fem. Pipe Thread	Catalog Number	L	M	M1	G
1/8	6800	1.12	.88	1.03	.50
1/4	6805	1.62	1.11	1.26	.69

## SAE 45° Flare Double

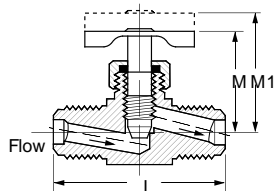

Tube O.D.	Catalog Number	L	M	M1
1/4	6715	1.38	.87	1.03

# Needle Valves

Brass  
Fittings

## SAE 45° Flare Straightway

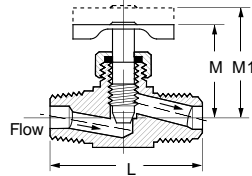
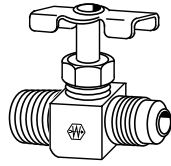

Tube O.D.	Male Pipe Thread	Catalog Number	L	M	M1
1/4	1/8	530	1.31	.88	1.03
1/4	1/4	6700	1.38	.88	1.09
5/16	1/8	630	1.38	.95	1.13
5/16	1/4	695	1.44	.87	1.02
3/8	1/4	700	1.68	1.00	1.15

## SAE 45° Flare Angle

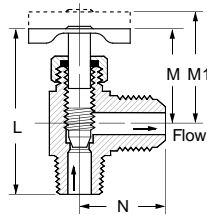
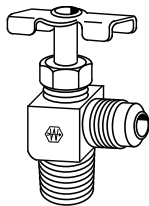

Tube O.D.	Male Pipe Thread	Catalog Number	L	M	M1	N
1/4	1/8	320	1.54	.86	1.07	.68
5/16	1/8	325	1.59	.94	1.22	.88
5/16	1/4	6703	1.94	1.00	1.31	.90
3/8	1/4	330	1.84	.90	1.21	.97

## Polyline® Straightway

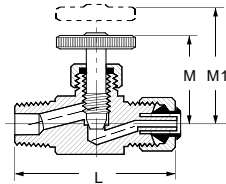
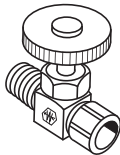

Tube O.D.	Male Pipe Thread	Catalog Number	L	M	M1
1/4	1/8	A690P	1.19	.86	1.01
3/8	1/4	A6760P	1.50	1.18	1.33

For replacement Polyline® nuts and sleeves, see page 61. Supplied with plastic sleeve.  
Temperature Range: -40°F to +150°F with plastic sleeve.

## Polyline® Angle

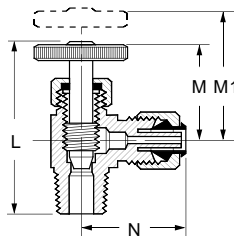
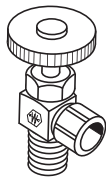

Tube O.D.	Male Pipe Thread	Catalog Number	L	M	M1	N
1/4	1/8	A555P	1.50	.82	1.04	.48
1/4	1/4	A556P	1.70	.84	1.06	.56
3/8	1/4	A6860P	1.85	.99	1.44	.64

For replacement Polyline® nuts and sleeves, see page 61. Supplied with plastic sleeve.  
Temperature Range: -40°F to +150°F with plastic sleeve.

B  
R  
A  
S  
S

 Refer to safety information regarding tubing selection on page 1.

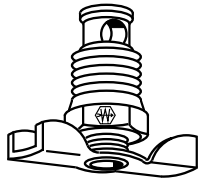
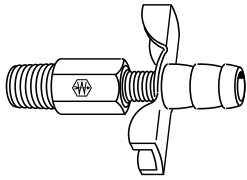

Drain Cocks and Drain Valves have been a specialty with Weatherhead since 1919. Millions are in use. The original design has proved so efficient that it is still the leader with most original equipment manufacturers. The metal-to-metal seat requires only hand tightening to assure positive leak-proof performance.

- **Material:** brass bodies/steel handles, except where noted.
- **Pressure:** 150 psi maximum (does not include hose or plastic tubing.)
- **Used With:** Copper, aluminum, steel, hose and plastic tubing where applicable.
- **Temperature:** -65°F to +250°F (-53°C to +121°C). (Refer to tubing temperature range.)
- **Conformance:** Designed for automotive or industrial use. Not intended for natural gas, LPG, nuclear or aircraft applications, except as noted.

### External Seat

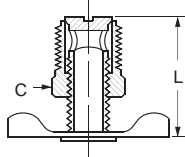
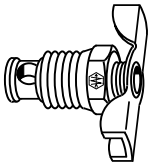

Male Pipe Thread	Catalog Number	Hex C	L
1/8	135	7/16	.90
1/4	145	9/16	1.00
3/8	270	11/16	1.25
1/2	108	7/8	1.52

### External Seat

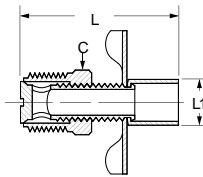
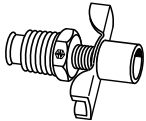

Male Pipe Thread	Catalog Number	Hex C	L	L1
1/4	6788	9/16	1.56	.44

### Internal Seat

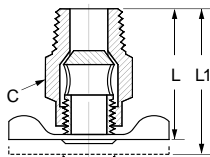
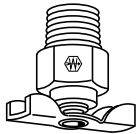

Male Pipe Thread	Catalog Number	Hex C	L	L1
1/8	130	17/32	1.15	1.30
1/4	140	5/8	1.32	1.50
1/4	190	9/16	1.25	1.41
3/8	230	11/16	1.34	1.50

### Internal Seat (Long)

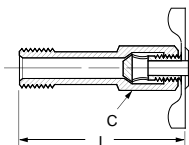
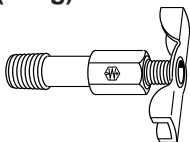

Male Pipe Thread	Catalog Number	Hex C	L
1/8	185	7/16	1.72

# Drain Cocks

**Brass  
Fittings**

## Internal Seat

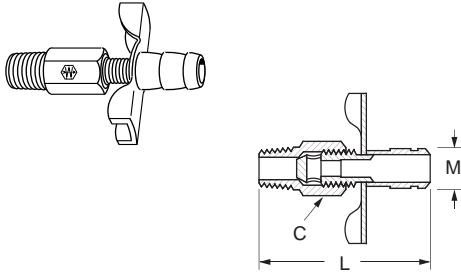

Male Pipe Thread	Catalog Number	Hex C	L	M
1/8	6783	13/32	1.63	.344

## Internal Seat Drain Valve

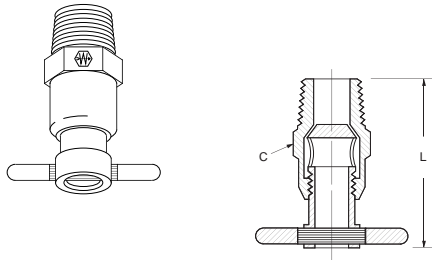

Male Pipe Thread	Catalog Number	Hex C	L
1/8	1424A	1/2	1.219
1/4	1425A	9/16	1.313
3/8	1426A	11/16	1.688

## Air Vent

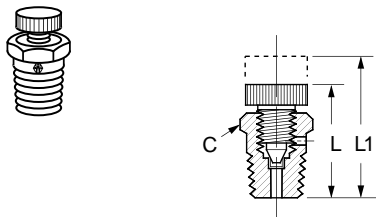

Set screw has 10-32 national fine thread.

Male Pipe Thread	Catalog Number	Hex C	L	L1
1/8	705	13/32	.78	.88

## Angle Bib Drain

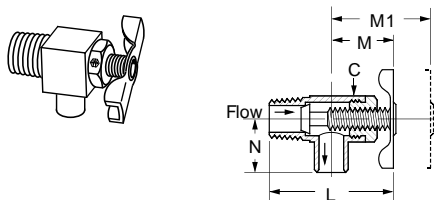

Male Pipe Thread	Catalog Number	Square C	L	M	M1	N
1/8	150	7/16	1.12	.57	.95	.38
1/4	120	5/8	1.76	.94	1.50	.66

## Angle Bib Drain

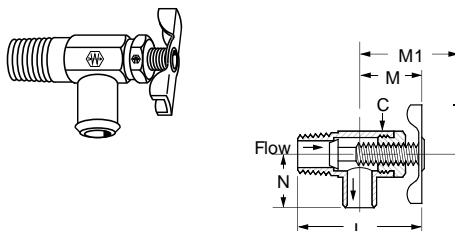

Hose I.D.	Male Pipe Thread	Catalog Number	Square C	L	M	M1	N
3/8	1/4	6660	9/16	1.33	.62	1.01	.66

B  
R  
A  
S  
S

**Hose to Pipe  
(Steel Body)**

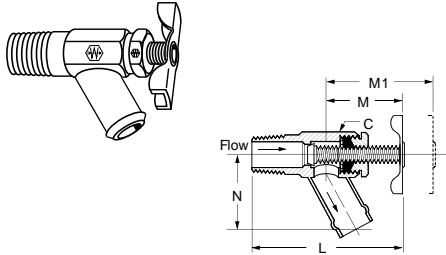

Hose Size	Male Pipe Thread	Catalog Number	Hex C	L	M	M1	N
5/8	3/8	<a href="#">211273A</a>	11/16	2.85	1.41	1.91	1.30

**Hose to Pipe  
(Steel Body)**

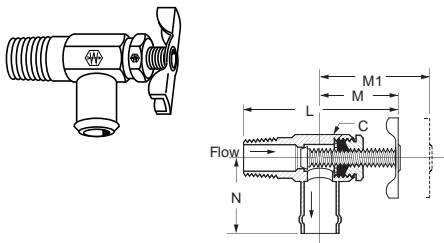

Hose I.D.	Male Pipe Thread	Catalog Number	Square C	L	M	M1	N
5/8	3/8	<a href="#">211280A</a>	11/16	2.85	1.10	1.47	1.19

**Pipe to Hose Shut-Off  
(Brass Body)**

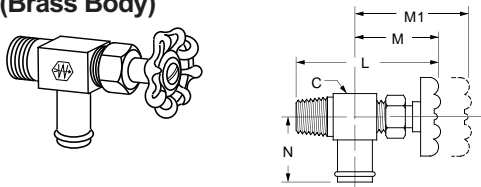

Red color coded aluminum handle.  
Handle Catalog Number [1427](#).

Hose Size	Male Pipe Thread	Catalog Number	Square C	L	M	M1	N
3/8	3/8	<a href="#">1422</a>	3/4	2.93	1.78	2.25	1.12
5/8	3/8	<a href="#">1423</a>	13/16	2.93	1.81	2.25	1.35
3/4	3/8	<a href="#">1433</a>	15/16	3.00	1.81	2.25	1.35
3/4	1/2	<a href="#">1451</a>	15/16	3.12	1.93	2.25	1.35

**Gasoline Shut-Off with Screen Filter**

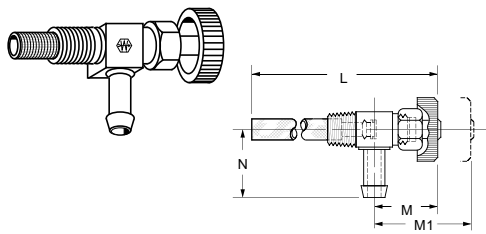

Hose Size	Male Pipe Thread	Catalog Number	L	M	M1	N
1/4	1/8	<a href="#">6600</a>	3.36	.80	.97	.84

**Air Tank Drain Valve**

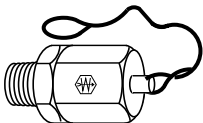

**NOTE:** Pull cable sideways.  
\*No loop on cable end.

Male Pipe Thread	Cable Length	Catalog Number
1/4	7"	<a href="#">1421-7</a>
1/4	18"	<a href="#">1421-18</a>
1/4	24"	<a href="#">1421-24</a>
1/4	32"	<a href="#">1421-32</a>
1/4	60"	<a href="#">1421-60</a>
1/4	60"	<a href="#">1421-60A*</a>



# Truck Valves

**Brass Fittings**

**Typical Application:** Used extensively in the trucking industry for cooling and fuel line applications.

**Material:** Forged brass bodies, steel handles.

**Pressure Range:** 200 psi maximum.

**Temperature:** -40°F to +250°F (-40°C to +121°C)

**Conformance:** Designed for trucking use. Not intended for natural gas, LPG, nuclear or aircraft applications.

**Note:** Buna-N o-ring sealed; Viton available on special order.

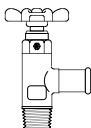
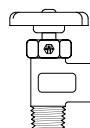
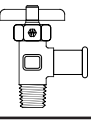
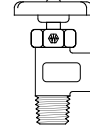
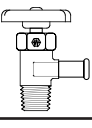
 <p><b>Truck Valve</b></p>	Hose I.D.	Pipe Thread	Catalog Number	 <p><b>Truck Valve</b></p>	Female Pipe Thread	Male Pipe Thread	Catalog Number
	5/8	1/2	7502		1/2	1/2	7508
 <p><b>Truck Valve</b></p>	Hose I.D.	Pipe Thread	Catalog Number	 <p><b>Truck Valve</b></p>	Female Pipe Thread	Male Pipe Thread	Catalog Number
	5/8	3/8	7504		3/8	3/8	7509
 <p><b>Truck Valve</b></p>	Hose I.D.	Pipe Thread	Catalog Number				
	3/8	3/8	7506				

# Plastic Drain Cocks

**Brass Fittings**











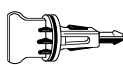
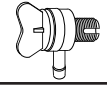

**Material:** Nylon 6 Fiber Reinforced.

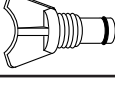
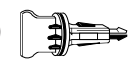
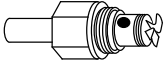
**Pressure Range:** Up to 25 psi.

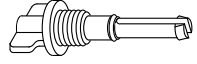
**Used With:** Automotive Radiators

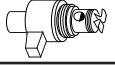
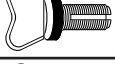
**Temperature:** -50°F to +180°F (-46°C to +82°C)

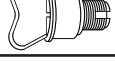
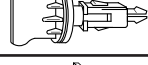
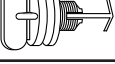
**Conformance:** Designed for automotive use. Not intended for natural gas, LPG, nuclear or aircraft applications.

Chrysler		Thread	Catalog Number	M12x1.5		Thread	Catalog Number
		Captive	110			M12x1.5	119
GM		Thread	Catalog Number	Ford and Mazda		Thread	Catalog Number
		Oversized	111			M10x1.25	121
Ford (Long)		Thread	Catalog Number	M14x2.0		Thread	Catalog Number
		Captive	112			M14x2.0	122
Ford (Short)		Thread	Catalog Number	Chrysler		Thread	Catalog Number
		Captive	113			5/8-18	123
M12x1.25		Thread	Catalog Number	Ford		Thread	Catalog Number
		M12x1.25	114			M14x2.0	124
M14x1.25		Thread	Catalog Number	Chrysler		Thread	Catalog Number
		M14x1.25	115			5/8-18	125
M10x1.25		Thread	Catalog Number	Chrysler		Thread	Catalog Number
		M10x1.25	116			5/8-18	126
M14x1.25		Thread	Catalog Number	GM		Thread	Catalog Number
		M14x1.25	117			Captive	127
M10x1.25		Thread	Catalog Number	GM		Thread	Catalog Number
		M10x1.25	118			1/2-18	128

BRASS

 Refer to safety information regarding tubing selection on page 1.

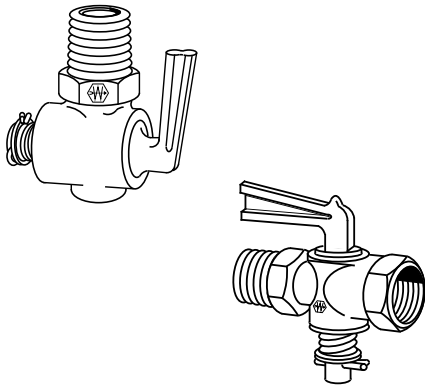

**Pressure Range:** 30 psi working pressure, except where noted.  
**Used With:** Copper, aluminum, steel and plastic tubing where applicable.  
**Material:** Brass bodies and handles.  
**Temperature:** -65°F to +250°F (-53°C to +121°C) with metal tubing. For use with plastic tubing, refer to the tubing temperature range.  
**Conformance:** Designed for automotive or industrial use. Not intended for natural gas, LPG, nuclear or aircraft applications, except as noted.  
**Ordering Information:** Order valve body, nut and sleeves by catalog number. Order valves with Selfalign® nuts and sleeves by adding suffix "S". Example: A694S. Order valves less nut and sleeve by adding prefix "B". Example: B694.  
**NOTE:** Ground Plug Drains and Shut-Offs use a universal lubricant satisfactory for use with most common fluids. However the lubricant may wash out at higher pressures or with some exotic fluids.

## Draincock

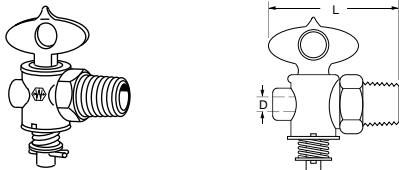

**Ratings:** Valves are designed to hold air pressure of 150 psi with one 1/4" bubble in 5 seconds permissible key leakage.

Male Pipe Thread	Catalog Number	D	L
1/4	<a href="#">W15310</a>	.188	1.56

## Ground Plug Drain

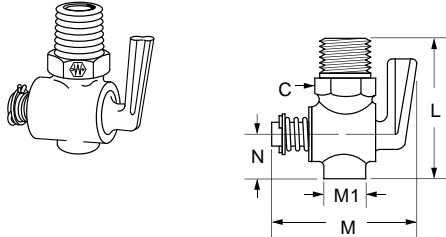

Male Pipe Thread	Catalog Number	Hex C	L	N	M	M1
1/8	<a href="#">6891</a>	9/16	1.93	.75	1.63	.87
1/4	<a href="#">6892</a>	5/8	1.62	.75	1.75	1.03
3/8	<a href="#">6893</a>	11/16	1.72	1.00	2.31	1.22

## Compression Flareless 3 Way Shut-Off

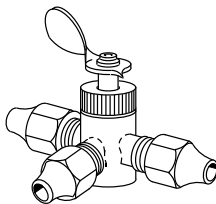

Tube O.D.	Catalog Number	Replacement Nuts	Replacement Sleeves
5/16	<a href="#">A6793</a>	<a href="#">1611x5♦</a>	<a href="#">60x5</a>

## SAE 45° Flare Double

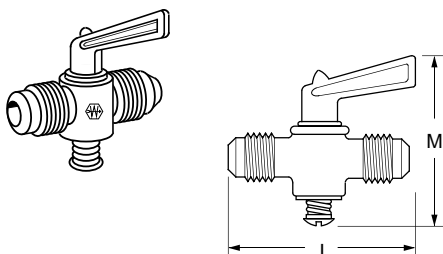

Tube O.D.	Catalog Number	L	M
1/4	<a href="#">6719</a>	1.88	1.88
5/16	<a href="#">6724</a>	1.88	1.88
3/8	<a href="#">6729</a>	2.00	1.88

♦MTO - Made To Order

# Ground Plug & Multiple Shut-Offs

**Brass  
Fittings**

## SAE 45° Flare Straightway

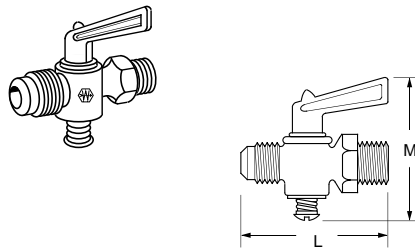

Tube O.D.	Male Pipe Thread	Catalog Number	L	M
1/4	1/8	<a href="#">537</a>	2.00	1.88
5/16	1/8	<a href="#">632</a>	2.03	1.88
5/16	1/4	<a href="#">702</a>	2.03	1.88
3/8	1/4	<a href="#">703</a>	2.06	1.88

## Compression Double

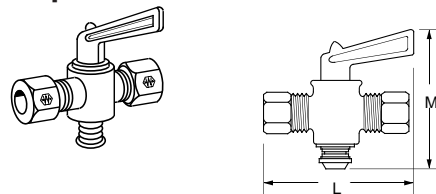

"S" suffix designates Selfalign® with Nuts and Sleeves.

Tube O.D.	Catalog Number	L	M
1/4	<a href="#">A6769</a>	2.12	1.88
1/4	<a href="#">A6769S</a>	2.12	1.88
5/16	<a href="#">A6774</a>	2.19	1.88
3/8	<a href="#">A6779</a>	2.25	1.88
3/8	<a href="#">A6779S</a>	2.25	1.88

## Compression Straightway

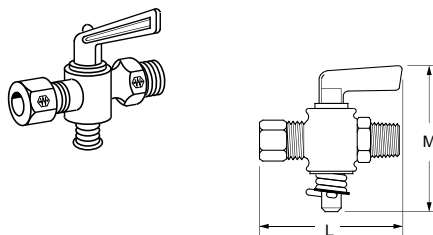

"S" suffix designates Selfalign® with Nuts and Sleeves.

Tube O.D.	Male Pipe Thread	Catalog Number	L	M
1/4	1/8	<a href="#">A694</a>	2.19	1.88
1/4	1/8	<a href="#">A694S</a>	2.19	1.88
1/4	1/4	<a href="#">A6754</a>	2.19	1.88
1/4	1/4	<a href="#">A6754S</a>	2.19	1.88
5/16	1/8	<a href="#">A664</a>	2.19	1.88
5/16	1/4	<a href="#">A6759</a>	2.25	1.88
3/8	1/4	<a href="#">A6764</a>	2.38	1.88
3/8	1/4	<a href="#">A6764S</a>	2.38	1.88

## Male to Female Pipe

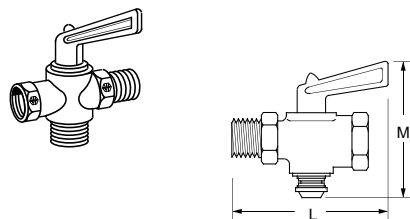

Male Pipe Thread	Fem. Pipe Thread	Catalog Number	L	M
1/8	1/8	<a href="#">6824</a>	2.00	1.88
1/4	1/4	<a href="#">6829</a>	2.12	1.88

## Truck Shut Off Male to Female Pipe

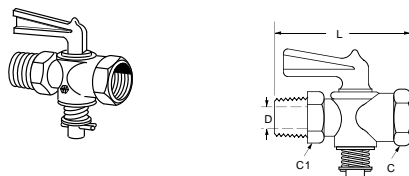

**Ratings:** Valves are designed to hold air pressure of 125 psi with one 1/4" bubble in 5 seconds permissible key leakage.

Male Pipe Thread	Fem. Pipe Thread	Catalog Number	Hex C	Hex C1	L	D
1/4	1/4	<a href="#">W20332</a>	5/8	3/4	1.96	.219

BRASS

## Marine Shut Off Male to Female Pipe

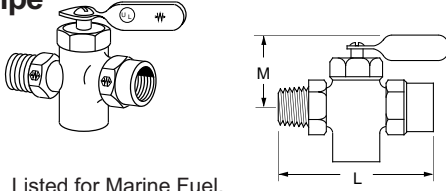

UL Listed for Marine Fuel.

Male Pipe Thread	Fem. Pipe Thread	Catalog Number	L	M
1/4	1/4	6828	2.22	1.97

## Female Pipe Double

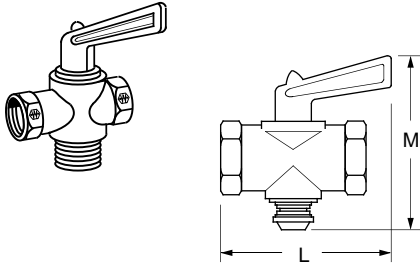

Fem. Pipe Thread	Catalog Number	L	M
1/8	6804	1.46	1.88
1/4	6809	1.70	1.88

## Three Way Shut-Off

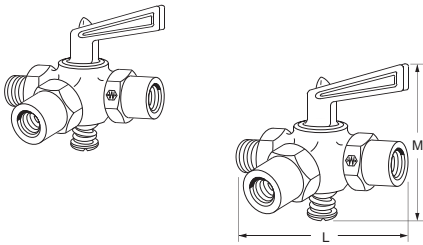

Male Pipe Thread	Fem. Pipe Thread	Catalog Number	L	M
1/8	1/8	6737	2.12	1.88

## 3 Way Multiple Shut-Off

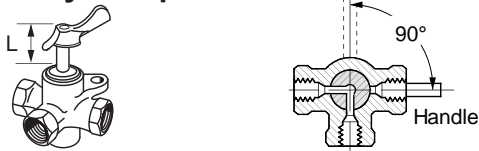

**Replacement Handle:** Catalog Number [6746](#).  
Includes Screw.  
Click-washer assembly positively holds valve in desired position and gives a pronounced click.

Male Pipe Thread	L Stem	Catalog Number
1/4	1.37	6749
3/8	1.37	6709

## 4 Way Multiple Shut-Off

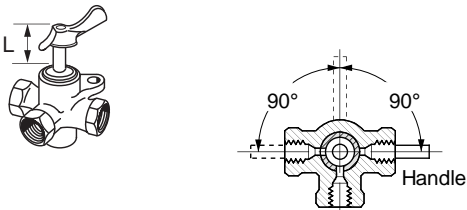



**Replacement Handle:** Catalog Number [6746](#).  
Includes Screw.  
Click-washer assembly positively holds valve in desired position and gives a pronounced click.

Fem. Pipe Thread	L Stem	Catalog Number
1/4	1.37	6747
1/4	2.37	6748
3/8	1.37	6707
3/8	2.37	6708

# Special Adapters

**Brass  
Fittings**

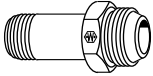
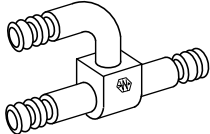
 Refer to safety information regarding tubing selection on page 1.

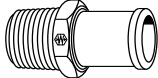
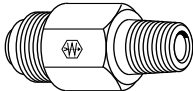
<p><b>Turbocharger Discharge Connector</b></p> 	<table border="1"> <thead> <tr> <th>Male Straight Thread</th> <th>Pipe Thread</th> <th>Catalog Number</th> </tr> </thead> <tbody> <tr> <td>1 AC-811 30° Flare Tube</td> <td>3/4</td> <td><b>1408</b></td> </tr> </tbody> </table>	Male Straight Thread	Pipe Thread	Catalog Number	1 AC-811 30° Flare Tube	3/4	<b>1408</b>						
Male Straight Thread	Pipe Thread	Catalog Number											
1 AC-811 30° Flare Tube	3/4	<b>1408</b>											
<p><b>Wiper Tee</b></p> 	<table border="1"> <thead> <tr> <th>Hose I.D.</th> <th>Catalog Number</th> </tr> </thead> <tbody> <tr> <td>1/4</td> <td><b>1410</b></td> </tr> </tbody> </table>	Hose I.D.	Catalog Number	1/4	<b>1410</b>								
Hose I.D.	Catalog Number												
1/4	<b>1410</b>												
<p><b>Transmission Oil Coolant Line Adapter</b></p> 	<table border="1"> <thead> <tr> <th>Tube O.D.</th> <th>Inverted Nut</th> <th>Tube Lgth.</th> <th>Catalog Number</th> </tr> </thead> <tbody> <tr> <td>5/16</td> <td>5/16</td> <td>4-1/2</td> <td><b>1428</b></td> </tr> <tr> <td>3/8</td> <td>3/8</td> <td>4-1/2</td> <td><b>1429</b></td> </tr> </tbody> </table>	Tube O.D.	Inverted Nut	Tube Lgth.	Catalog Number	5/16	5/16	4-1/2	<b>1428</b>	3/8	3/8	4-1/2	<b>1429</b>
Tube O.D.	Inverted Nut	Tube Lgth.	Catalog Number										
5/16	5/16	4-1/2	<b>1428</b>										
3/8	3/8	4-1/2	<b>1429</b>										
<p><b>Water Line Connector</b></p> 	<table border="1"> <thead> <tr> <th>Hose I.D.</th> <th>Male Pipe Thread</th> <th>Catalog Number</th> </tr> </thead> <tbody> <tr> <td>5/8</td> <td>3/8</td> <td><b>05710B-106</b></td> </tr> <tr> <td>5/8</td> <td>1/2</td> <td><b>05710B-108</b></td> </tr> <tr> <td>3/4</td> <td>1/2</td> <td><b>05712B-108</b></td> </tr> </tbody> </table> <p>For additional 057B Series ends consult the Weatherhead Hose Assembly Catalog</p>	Hose I.D.	Male Pipe Thread	Catalog Number	5/8	3/8	<b>05710B-106</b>	5/8	1/2	<b>05710B-108</b>	3/4	1/2	<b>05712B-108</b>
Hose I.D.	Male Pipe Thread	Catalog Number											
5/8	3/8	<b>05710B-106</b>											
5/8	1/2	<b>05710B-108</b>											
3/4	1/2	<b>05712B-108</b>											
<p><b>Truck Oil Line Extended 45° Fitting</b> (Replaces Roto Master No. 10-35)</p> 	<table border="1"> <thead> <tr> <th>SAE 45° Tube Size</th> <th>Male Pipe Size</th> <th>Catalog Number</th> </tr> </thead> <tbody> <tr> <td>3/8</td> <td>1/4</td> <td><b>1432</b></td> </tr> </tbody> </table>	SAE 45° Tube Size	Male Pipe Size	Catalog Number	3/8	1/4	<b>1432</b>						
SAE 45° Tube Size	Male Pipe Size	Catalog Number											
3/8	1/4	<b>1432</b>											

BRASS

 Refer to safety information regarding tubing selection on page 1.

## Ford Transmission Elbow

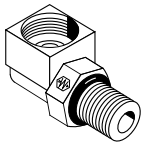

Includes O-Ring.

Inv. Tube	Straight Male Pipe Thread	Catalog Number
5/16	1/8-27	1437

## Power Steering 37° Adapter (Brass)

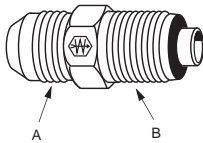

Includes O-Ring.

Tube Size	Thread A	Thread B	Catalog Number
1/4	7/16-20	9/16-18	1440
3/8	9/16-18	5/8-18	1439

## Metric Power Steering Adapter

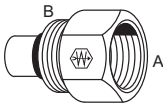

Includes O-Ring.

Tube	Thread A	Thread B	Catalog Number
3/8	5/8-18	M14x1.5	1445
3/8	5/8-18	M16x1.5	1446
3/8	5/8-18	M18x1.5	1447

## Ford Power Steering Fitting

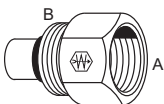

Includes O-Ring.

Inverted Female Port	Male O-Ring	Catalog Number
3/8	11/16-18	1444

## Restriction Pipe Adapter (With .0625 Orifice)

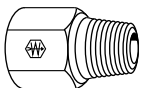

Male and Fem. Pipe Thread	Catalog Number
1/8	1512

# Special Adapters

**Brass  
Fittings**

 Refer to safety information regarding tubing selection on page 1.

## Carburetor to Fuel Line Adapter (Ford)

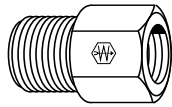

For use with **59x4**

Tube Size	Male Pipe Thread	Thread Size	Catalog Number
1/4	1/8	1/2-20	<b>1513</b>

## Fuel Line Adapter

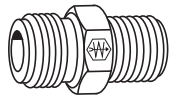

Inv. Tube Size	Male Pipe Thread	Catalog Number
1/2-20	1/8	<b>1514</b>

## AC Type Adapter



Tube Size	S.A.E. Tube Size	Catalog Number
1/4	1/4	<b>1521</b>

## Adapter SAE 45° Flare to Inv. Flare

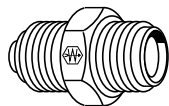

SAE Tube Size	Inverted Male	Catalog Number
1/4	3/16	<b>1518</b>
1/4	1/4	<b>1522</b>
3/8	5/16	<b>1553</b>
3/8	3/8	<b>1563</b>
3/8	7/16	<b>1554</b>

## Carburetion Inlet (Steel)



Inv. Seat	Male Thread	Catalog Number
3/8	7/8-20	<b>1596</b>
5/16	7/8-20	<b>1597</b>

B  
R  
A  
S  
S

 Refer to safety information regarding tubing selection on page 1.

## Special Steel Bushing

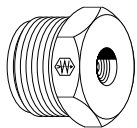

Male Thread	Female Pipe Thread	Catalog Number
1-1/16-16UN-2A	1/8	7977
1-1/16-16UN-2A	3/8	7978

## Water Line Elbow

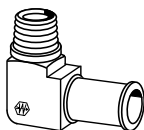

Hose I.D.	Male Pipe Thread	Catalog Number
5/8	3/8	05710B-C06

## SAE 37° Flare to O-Ring Port Adapter (Steel)

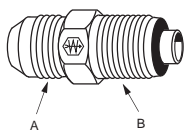

Includes O-Ring.

Tube Size A	Port Size B	Catalog Number
1/4	1/4	41157x4
3/8	3/8	41157x6
1/2	1/2	41157x8
5/8	5/8	41157x10
3/4	3/4	41157x12

## SAE Flare to Metric O-Ring Port Adapter (Steel) (with o-ring)

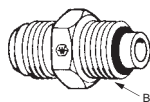

Includes O-Ring.

SAE Tube Size	Thread B	Catalog Number
3/8	M14x1.5	M41157x6x14
3/8	M16x1.5	M41157x6x16
3/8	M18x1.5	M41157x6x18

**Application:** GM power steering with Saginaw steering and rack and pinion steering systems.

## BSPP Male To NPTF Female Adapter

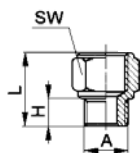

Male BSPP	Female NPTF Thread	Catalog Number	H	L	SW (mm)
1/8	1/8	1150x2x2PP	.27	.67	14
1/4	1/4	1150x4x4PP	.32	.91	17
3/8	3/8	1150x6x6PP	.35	.96	22
1/2	1/2	1150x8x8PP	.39	1.16	27



### BSPP Female To NPTF Male Adapter

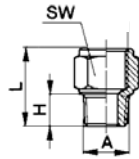

†UNF thread

Male BSPP	Female NPTF Thread	Catalog Number	H	L	SW (mm)
M5*	10-32†	1100x5MMxA	.18	.47	8
1/8	1/8	1100x2PPx2	.37	.77	14
1/4	1/4	1100x4PPx4	.51	1.06	17
3/8	3/8	1100x6PPx6	.51	1.08	19

\*M5 has 0.8mm Thread Pitch. M5 seals with nylon washer, included.

### Ford Nut

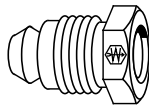

For use with **1513**  
(Nut similar to **59x4** for 3/16" tube, use **6100x3**)

Tube Size	Thread Size	Catalog Number
1/4	1/2-20	59x4

### Transmission Coolant Line Adapters (GMC)

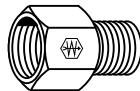

Inv. Female	Inv. Male	Catalog Number
3/8 (5/8-18)	5/16 (1/2-20)	7915
5/16 (1/2-20)	3/8 (5/8-18)	7916

### AC8111 (Steel) Connector

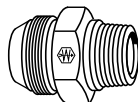

**Application:** PTT Thread 30° tube to male pipe adapter for diesel engines.

Tube Size	Male Pipe	Catalog Number
1 (1-5/16-14)	1	C9200
1 (1-5/16-14)	3/4	C9240

 Refer to safety information regarding tubing selection on page 1.

Adapters can be used to adapt standard steel brake lines to the different size ports used in dual master cylinders. The tube O.D. is the outside diameter of the steel brake line. Thread size can be determined by measuring with a U.S. or Metric screw pitch gauge. See page 16.

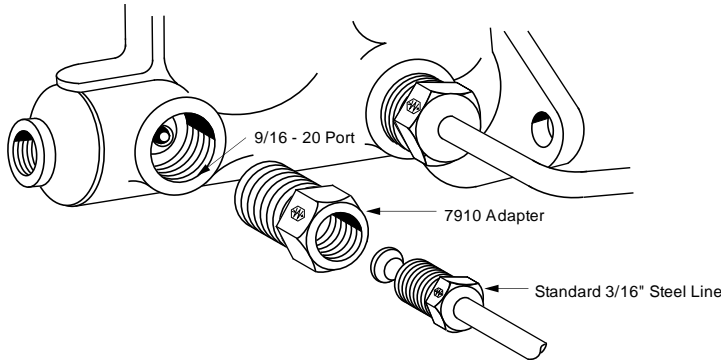

**STANDARD INVERTED FLARE TUBE AND THREAD SIZE**

Tube Size	1/8	3/16	1/4	5/16	3/8	7/16	1/2	5/8	3/4	7/8	1
Thread Size	5/16-28	3/8-24	7/16-24	1/2-20	5/8-18	11/16-18	3/4-18	7/8-18	1-1/16-16	1-3/16-16	1-5/16-16

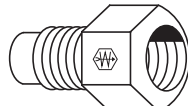
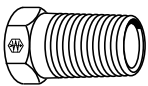
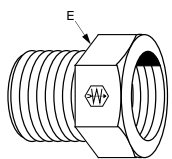
<p><b>Standard Tube Nut (Steel)</b></p>  <p>*11/16-18 Thread</p>	<p><b>Tube Size</b></p> <p>1/8</p> <p>3/16</p> <p>1/4</p> <p>5/16</p> <p>3/8</p> <p>3/8</p> <p>7/16</p> <p>1/2</p> <p>5/8</p> <p>3/4</p> <p>7/8</p> <p>1</p>	<p><b>Catalog Number</b></p> <p>105x2</p> <p>105x3</p> <p>105x4</p> <p>105x5</p> <p>105x6</p> <p>105x6x7*</p> <p>105x7</p> <p>105x8</p> <p>105x10</p> <p>105x12</p> <p>105x14</p> <p>105x16</p>	<p><b>Dual Master Cylinder Adapter</b></p> 	<p><b>Inverted Male Thread</b></p> <p>3/16</p> <p>5/16</p>	<p><b>Inverted Female Thread</b></p> <p>3/16</p> <p>3/16</p>	<p><b>Catalog Number</b></p> <p>1441</p> <p>7897</p>
	<p><b>Long Tube Nut (Steel)</b></p> 	<p><b>Tube Size</b></p> <p>3/16</p> <p>1/4</p>		<p><b>Catalog Number</b></p> <p>7896x3</p> <p>7896x4</p>	<p><b>Dual Master Cylinder Adapter</b></p>  <p>† 3/16", 1/4", 5/16" Tube Connection with 1/2-20 Thread. *Seals On Hex Face (E)</p>	<p><b>Inverted Male Thread (Exceptions Noted)</b></p> <p>3/16(9/16-18)</p> <p>3/16(9/16-18)</p> <p>3/16(9/16-20)</p> <p>3/16</p> <p>1/4</p> <p>7/16-20</p> <p>1/4 (9/16-18)</p> <p>1/4</p> <p>5/16</p> <p>5/16</p> <p>5/16</p> <p>5/16</p> <p>5/16</p> <p>5/16</p> <p>5/16</p> <p>5/16</p> <p>5/16</p> <p>3/8 NPTF</p> <p>3/8</p>

# Hydraulic Brake Fittings

**Brass  
Fittings**

## Towed Trailer Brake Tee

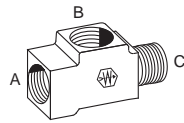

Inverted Seat		Male Thread		Catalog Number
A	B	C		
3/16 (3/8-24)	3/16 (3/8-24)	3/16 inv. (3/8-24)		<b>7900</b>
3/16 (1/2-20)	3/16 (3/8-24)	1/2-20 inv.		<b>7906</b>
3/16 (9/16-18)	3/16 (3/8-24)	3/16 inv. (9/16-18)		<b>7933</b>
3/16 (9/16-20)	3/16 (3/8-24)	3/16 inv. (9/16-20)		<b>7905</b>
3/16 (7/16-24)	3/16 (3/8-24)	1/4 inv. (7/16-24)		<b>7914</b>
3/16 (3/8-24)	1/4 (7/16-24)	3/16 inv. (3/8-24)		<b>7899*</b>
1/4 (7/16-24)	3/16 (3/8-24)	1/4 inv. (7/16-24)		<b>7901</b>
1/4 (7/16-24)	3/16 (3/8-24)	1/4 pipe		<b>7902*</b>
1/4 (9/16-18)	3/16 (3/8-24)	1/4 inv. (9/16-18)		<b>7904</b>
1/4 (7/16-24)	1/4 (7/16-24)	1/4 inv. (7/16-24)		<b>7898</b>

## Metric Hydraulic Brake Fittings

### How to Measure Metric Threads

Metric threads are measured and specified by the thread diameter in millimeters and the pitch in millimeters per thread. If dimension "A" is 22mm and dimension "B" (crest to crest distance) is 1.5mm, then the metric thread size is M22 x 1.5.

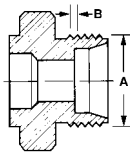

## Metric Adapter

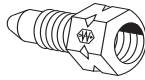

Male Thread	Tube O.D./ Female Thread	Catalog Number
M10 x 1.0	3/16 (3/8-24)	<b>1442*</b>
M11 x 1.5	3/16 (M10 x 1.0)	<b>7935*</b>
M12 x 1.0	3/16 (M10 x 1.0)	<b>7936*</b>
M13 x 1.5	3/16 (M10 x 1.0)	<b>7937*</b>

\*Use standard S Series Brake Lines. See page 130.

## Metric Adapter

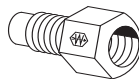

Male Thread	Tube O.D./ Female Thread	Catalog Number
M10 x 1.0	3/16 (3/8-24)	<b>1443*</b>
M11 x 1.5	3/16 (M10-1.0)	<b>7942**♦</b>
M12 x 1.0	3/16 (M10-1.0)	<b>7943**♦</b>
M13 x 1.5	3/16 (M10-1.0)	<b>7944**♦</b>

\*Use S Series Brake Lines. (standard flare)

\*\*Use SJ Series Steel Brake Lines. (standard flare)

## Adapter Standard to Metric Bubble

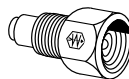

Female Std. Fl. Seat	Male Bubble Fl. Tube	Catalog Number
3/16" (3/8-24 thread)	4.762 (3/16") (10x1.25 thread)	<b>7970</b>

Used on Fiat applications when converting 3/16" (3/8-24) inverted flare brake lines to 3/16" (10x1.25) metric thread bubble flare.

## Adapter Standard to Bubble

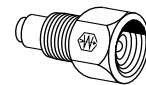

Female Inv. Fl. Seat	Male Bubble Fl. Tube	Catalog Number
3/16" (3/8-24 thread)	1/4" (7/16-20 thread)	<b>7971</b>

Used on British vehicles when converting Edelmann 3/16" (3/8-24) STD thread inverted flare brakelines to 1/4" (7/16-20) STD thread bubble flare.

## Adapter Standard to Metric Bubble

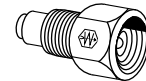

Female Inv. Fl. Seat	Male Metric Bubble Flare Thread	Catalog Number
3/16" (3/8-24 thread)	13x1.5	<b>7972</b>
3/16" (3/8-24 thread)	11x1.5	<b>7973</b>
3/16" (3/8-24 thread)	12x1.0	<b>7974</b>

## Metric Union

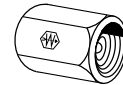

Bubble Fl. Seat	Thread Size	Catalog Number
3/16"	10 x 1.0	<b>7975</b>

For joining Edelmann 6300 Series metric thread bubble flare 3/16" brakelines.

## Adapter Standard to Metric Standard

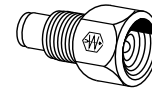

Female Inv. Fl. Seat	Male Bubble Fl. Tube	Catalog Number
3/16" (3/8-24 thread)	4.762 (3/16") (10x1.25 thread)	<b>7976</b>

Adapts Edelmann 3/16" brake lines to most Japanese Cars (Colt, Datsun, LUV, Mazda, Toyota)

## Metric Towed Trailer Brake Tee

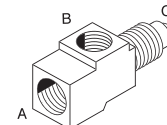

Inverted A	Seat B	Male Thread C	Catalog Number
3/16 (M10x1.0)	3/16 (3/8-24)	3/16 (M10x1.0)	<b>7918♦</b>
3/16 (M10x1.0) ISO	3/16 (3/8-24)	3/16 (M10x1.0) ISO	<b>7919†♦</b>
3/16 (M11x1.5)	3/16 (3/8-24)	3/16 (M11x1.5)	<b>7920†♦</b>
3/16 (M12x1.0)	3/16 (3/8-24)	3/16 (M12x1.0)	<b>7921†</b>
3/16 (M13x1.5)	3/16 (3/8-24)	3/16 (M13x1.5)	<b>7922†♦</b>



†Bubble flare type

♦MTO - Made To Order

BRASS

# Brass Fittings

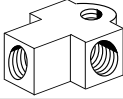
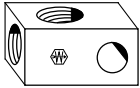
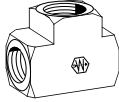
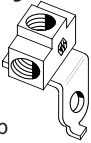

# Hydraulic Brake Fittings

<b>Brake Fittings</b> 	<b>Inv. Seat</b> 1/4	<b>Bolt Hole</b> 19/32	<b>Catalog Number</b> 7709	<b>Rear Axle Tee</b> 	<b>Inv. Seat</b> 3/16 (2)	<b>Bolt Hole</b> 9/32	<b>Hose End Port</b> 3/8-24	<b>Catalog Number</b> 7805
					<b>Inv. Seat</b> 3/16 (2)	<b>Hose End Port</b> 7/16-20	<b>Catalog Number</b> 7907*	
<b>Tee Connector</b> 	<b>Inv. Seat</b> 1/4 (3)	<b>Bolt Hole</b> 11/32	<b>Catalog Number</b> 7708*	<b>Tee</b> 	<b>Tube O.D.</b> 3/16	<b>Thread Size</b> 3/8-24	<b>Catalog Number</b> 7896x3	
					<b>Tube O.D.</b> 1/4	<b>Thread Size</b> 7/16-24	<b>Catalog Number</b> 7896x4	
<b>Strap Tee Assembly</b> 	<b>Inv. Seat</b> 3/16 (3)	<b>Bolt Hole</b> 11/32	<b>Catalog Number</b> 7812	<b>Long Tube Nut (Steel)</b> 	<b>Spring Lock</b> 			<b>Catalog Number</b> 5188
	<b>Inv. Seat</b> 1/4 (3)	<b>Bolt Hole</b> 11/32	<b>Catalog Number</b> 7765*					1/2" Clip or Spring Lock

\*Has flat strap

# Brass Fittings

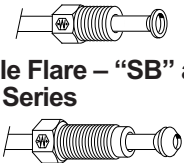
# Steel Brake Lines

<b>Steel Brake Lines for Domestic Vehicles</b> Standard Flare – “S” Series 	<b>Length</b>	<b>Catalog Number</b> 3/16" O.D.	<b>Catalog Number</b> 1/4" O.D.	<b>Catalog Number</b> 5/16" O.D.	<b>Catalog Number</b> 3/8" O.D.
	6" 8" 10" 12" 20" 30" 40" 51" 60" 72" UNION	S306 S308 S310 S312 S320 S330 S340 S351 S360 S372 302x3	– S408 – S412 S420 S430 S440 S451 S460 – 302x4	– – – S512 S520 S530 S540 S551 S560 – 302x5	– – – S612 S620 S630 S640 S651 S660 – 302x6
<b>Steel Brake Lines for Imported Vehicles</b> Standard Flare – “SJ” Series Bubble Flare – “SB” and “SC” Series 	<b>Length</b>	<b>British Vehicles*</b> 3/8-24 Thread Catalog Number 3/16" O.D.	<b>Japanese Vehicles</b> 10-1.0mm**Thread Catalog Number 3/16" O.D.	<b>European Vehicles*</b> 10-1.0mm Thread Catalog Number 3/16" O.D.	
	8" 12" 20" 30" 40" 51" 60" UNION	SB308 SB312 SB320 SB330 SB340 SB351 SB360 7940	SJ308 SJ312 SJ320 SJ330 SJ340 SJ351 SJ360 7934A	SC308 SC312 SC320 SC330 SC340 SC351 SC360 7941	
<b>Brake Line Unions for Domestic and Imported Vehicles</b> 	<b>Description</b>				<b>Catalog No.</b>
	3/16" line to 3/16" line (3/8-24 thread), (Standard Flare) 'S' Series 1/4" line to 1/4" (7/16-24 thread), (Standard Flare) 'S' Series 5/16" line to 5/16" line (1/2-20 thread), (Standard Flare) 'S' Series 3/8" line to 3/8" line (5/8-18 thread), (Standard Flare) 'S' Series British line to British line (3/8-24 thread), (ISO flare) 'SB' Series (Steel) European line to European line (10-1.0mm thread), (Bubble Flare) 'SC' Series (Steel) Japanese line to Japanese line (10-1.0mm thread), (Standard Flare) 'SJ' Series (Brass)				302x3 302x4 302x5 302x6 7940 7941* 7934A

\*MTO - Made To Order

 Refer to safety information regarding tubing selection on page 1.

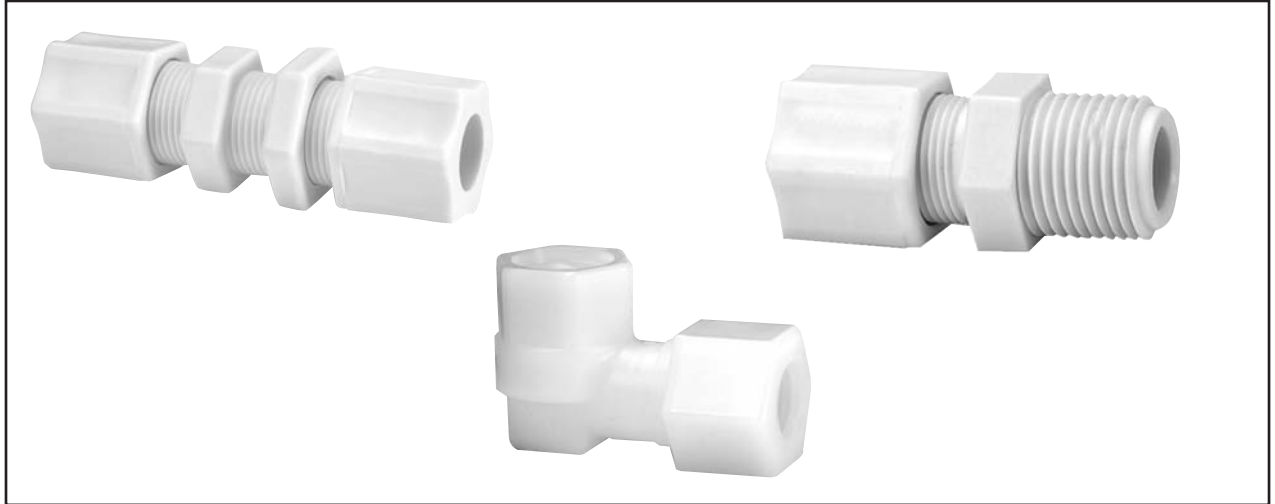

### Boston Weatherhead Molded Compression Tube Fittings

**Sizes:** Available in sizes 1/8" through 3/4" tube OD (7/8" tube OD and metric tube sizes available on request from Boston Weatherhead Customer Satisfaction at 1-800-432-6006.)

**Materials:** Molded as standard in two materials: nylon and polypropylene

*Nylon characteristics:*

- good resistance to organic solvents, oils, and gasoline
- excellent impact resistance
- tolerant to repeated steam for wash down and longtime weathering
- F.D.A. and N.S.F. listed
- operating temperatures -40°F to 200°F (-40°C to 93°C) – not to exceed temperature specification of tubing

*Polypropylene characteristics:*

- good chemical and corrosion resistance
- opaque
- 20% glass filled
- N.S.F. listed
- operating temperatures -30°F to 200°F (-34°C to 93°C) – not to exceed temperature specification of tubing

Available on request in two materials: Celcon®\* (acetal copolymer) or KYNAR®\*\* (polyvinylidene fluoride)

**Styles:** Available in two standard styles:

*Ferrule Nut* (integral nut and sleeve for soft tubing to 50 PSI<sup>†</sup>)

- features ferrule and nut molded as a single part, eliminating the need for a two-piece assembly

*Gripper Nut with separate plastic sleeve* (for sure-grip with plastic tubing up to 220 PSI<sup>†</sup>)

- for higher pressure applications

**Features and Benefits:**

- leak-free performance
- high integrity in both mechanical and acoustical vibrations
- ten styles and over 400 part number configurations to meet your needs
- easy fitting assembly – no special tools or tube preparation necessary
- reliability in side-loaded applications allows for compact plumbing
- fittings are manufactured for use with PT200, PT240, and TP160 Boston Weatherhead plastic tubing
- fittings come fully assembled – for your convenience
- very low resistance to media flow resulting from material and internal surfaces
- no metal parts to corrode or present a safety hazard with aggressive chemicals
- ISO 9001 Certified

\* Celcon® is a registered trademark of Ticona.

\*\* KYNAR® is a registered trademark of Elf Atochem North America, Inc.

<sup>†</sup> Operating temperatures of Boston Weatherhead Tube Fittings are regulated by ambient and fluid temperatures, type of fluid being carried, tubing type and conditions of mechanical abuse. Pressures in excess of above specifications in all fitting sizes should be tested by the customer in the particular application.

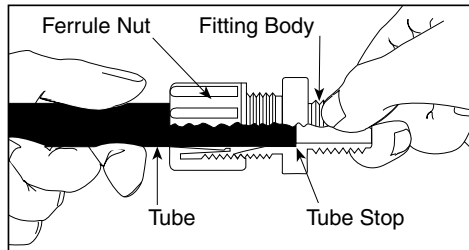

## Molded Compression Tube Fittings Assembly Instructions

### Maximum Operating Pressure:

Ferrule Nut series = 50 PSI max

Gripper Nut series = 220 PSI max

Maximum operating pressures are dictated by the combination of tubing and fitting. The lowest pressure of the individual components will decide the actual operating pressure of the assembly.

### Temperature Range:

Nylon = -40°F to +200°F (-40°C to +93°C)

Polypropylene = -30°F to +200°F (-34°C to +93°C)

Ranges are at maximum operating pressures (refer to tubing temperature range). The overlap of temperature ranges of the individual components will decide the actual temperature range of the assembly.

### Used with:

Weatherhead plastic tubing: TP160, PT200, and PT240.

Tube inserts are recommended for optimal performance with Weatherhead PT200 tubing.

**FERRULE NUT**  
WITH INTEGRAL SLEEVE  
LOW PRESSURE APPLICATIONS  
SOFT PLASTIC TUBING  
\*50 P.S.I.

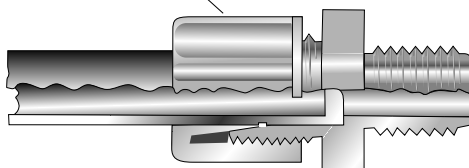

WITH PLASTIC GRIPPER  
FOR USE WITH PLASTIC TUBING  
FOR SURE GRIP  
\*220 P.S.I.

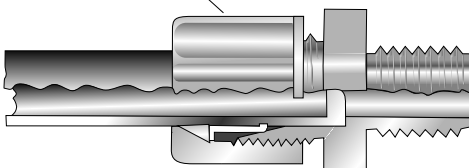

### Assembly Instructions:

- Cut tubing to desired length; be sure the tube end is cut properly (maximum 10° cutting angle allowed).
- Insert the tubing through the back of the nut all the way through the nut assembly to the tube stop in the fitting body (see illustration). If the tubing does not enter the nut easily, loosen the nut one turn and then insert the tubing all the way to the tube stop in the fitting body.
- Turn the nut to hand-tight.
- Tighten the nut an additional 2 to 2-1/2 turns past hand-tight or until the nut bottoms against the fitting body, whichever comes first.
- All nuts must be retightened when the system reaches projected operating temperature.

## Ordering Information

Molded compression tube fittings are available in nylon and in polypropylene. They are also available by special order in KYNAR®\*\* (polyvinylidene fluoride) or Celcon®\* (acetal copolymer). To order fittings in KYNAR® or Celcon®, call Boston Weatherhead Customer Satisfaction at 1-800-432-6006. Refer to Chemical Resistance Chart, pages 28-32. For detailed information on chemical compatibility, call Boston Weatherhead Technical Support 1-800-PRO-DANA. General material characteristics are as follows:

**Nylon**, F.D.A. and N.S.F. listed, has good resistance to organic solvents, oils and gasoline. Good strength at high temperatures. Cold and hot-water applications. Longtime weathering resistance. Good impact resistance, both single and repeated. Not recommended for use with bleach, acids, or chlorine.

**Polypropylene**, N.S.F. listed, has good chemical resistance. Withstands continuous temperatures up to 215°F (not to exceed temperature specification of tubing). Unaffected by most weak acids, alkalies, alcohols and ketones. Do not use with oxidants or strong acids or in continuous sunlight. 20% glass filled for improved stiffness.

**KYNAR®**, an F.D.A. and N.S.F. listed polyvinylidene fluoride, has outstanding chemical resistance for handling highly corrosive fluids.

**Celcon®**, an acetal copolymer, N.S.F. listed and U.S.D.A. and F.D.A. listed for coffee, milk and antibiotics, has high tensile strength and good impact resistance over a broad temperature range. Translucent white color. Not affected by continuous hot-water service and works smoothly with metal tubing. Celcon® cannot be recommended for continuous exposure to solutions with a chlorine concentration greater than 1 ppm. Suggested maximum continuous-use temperature is 220°F in air and 180°F in water (not to exceed temperature specification of tubing). Unaffected by most inorganics, except sulfuric, nitric and hydrochloric acids. Should not be continuously exposed to sunlight.

Most fittings can be ordered with a GRIPPER style nut. Fittings with a GRIPPER style nut are capable of handling greater pressure than those with standard style nut. See page 131. For ordering fittings with 'GRIPPER' nut, add 'G' to the end of the part number (example: 1568x4x4G or 1568Px4x4G). Some fittings are NOT available with the GRIPPER style nut, while others are ONLY available with the GRIPPER style nut, as noted on page 133-137. For more information, call Boston Weatherhead Technical Support 1-800-PRO-DANA.

**NOTE:** It is not necessary to disassemble the fitting for assembly. Merely insert tubing to stop and tighten compression nut.

132 \* Celcon® is a registered trademark of Ticona.

\*\* KYNAR® is a registered trademark of Elf Atochem North America, Inc.

# Molded Compression Tube Fittings

Plastic Fittings

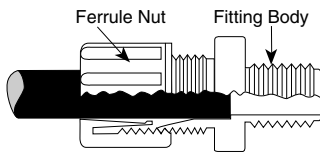

<b>Tube O.D.</b>	1/8 (.125)	1/4 (.250)	5/16 (.312)	3/8 (.375)	1/2 (.500)	5/8 (.625)	3/4 (.750)	7/8 (.875)
<b>Tube Thread Size</b>	5/16-24	7/16-20	1/2-20	5/8-20	3/4-20	7/8-20	1-1/16-20	1-3/16-16

## Male Connector

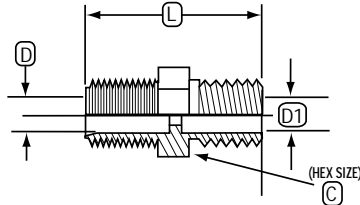

Tube O.D.	Pipe Thread	Catalog Number Nylon	Catalog Number Polypropylene	L	D	Hex C	D1
1/8	1/8	1568x2*	1568Px2*	.88	.13	7/16	.23
1/4	1/8	1568x4	1568Px4	.99	.26	5/8	.25
1/4	1/4	1568x4x4	1568Px4x4	1.17	.26	5/8	.31
1/4	3/8	1568x4x6G*	1568Px4x6	1.20	.26	13/16	.38
5/16	1/8	1568x5	1568Px5	1.00	.32	11/16	.23
5/16	1/4	1568x5x4	1568Px5x4	1.19	.32	11/16	.31
3/8	1/8	1568x6x2	1568Px6x2	1.14	.38	13/16	.30
3/8	1/4	1568x6	1568Px6	1.30	.38	13/16	.31
3/8	3/8	1568x6x6	1568Px6x6	1.34	.38	13/16	.38
3/8	1/2	1568x6x8	1568Px6x8	1.59	.38	59/64	.56
1/2	1/8	1568x8x2G*	1568Px8x2G*	1.23	.51	15/16	.25
1/2	1/4	1568x8x4	1568Px8x4	1.42	.51	15/16	.31
1/2	3/8	1568x8	1568Px8	1.47	.51	15/16	.38
1/2	1/2	1568x8x8	1568Px8x8	1.61	.51	15/16	.47
5/8	3/8	1568x10x6G*	1568Px10x6G*	1.50	.63	1-1/16	.50
5/8	1/2	1568x10G*	1568Px10G*	1.66	.63	1-1/16	.50
3/4	3/4	1568x12x12G*	1568Px12x12G*	1.92	.76	1-5/16	.64

## Union Connector

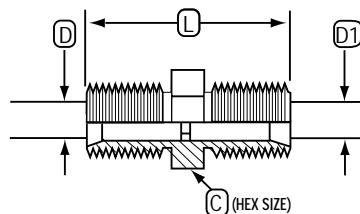

Tube O.D.	Thread	Catalog Number Nylon	Catalog Number Polypropylene	L	D, D1	Hex C
1/4	7/16 -20	1562x4	1562Px4	.98	.26	5/8
5/16	1/2 -20	1562x5	1562Px5	1.03	.32	11/16
3/8	5/8 -20	1562x6	1562Px6	1.23	.38	13/16
1/2	3/4 -20	1562x8	1562Px8	1.44	.51	15/16
5/8	7/8 -20	1562x10G*	1562Px10G*	1.50	.63	1-1/16
3/4	1-1/16 -20	1562x12G*	1562Px12G*	1.75	.76	1-5/16

Tube O.D.	Catalog Number Nylon	Catalog Number Polypropylene	L	D	Hex C	D1
1/4 - 1/8	1562x4x2*	1562Px4x2*	.92	.26	5/8	.13
5/16 - 1/4	1562x5x4*	1562Px5x4G*	1.00	.32	11/16	.265
3/8 - 1/4	1562x6x4	1562Px6x4	1.19	.38	13/16	.26
1/2 - 3/8	1562x8x6	1562Px8x6	1.33	.51	15/16	.38
5/8 - 3/8	1562x10x6G*	1562Px10x6G*	1.34	.63	1-1/16	.38
5/8 - 1/2	1562x10x8G*	1562Px10x8G*	1.47	.76	1-1/16	.51

\* Not available with GRIPPER style nut    \* Sold ONLY with GRIPPER style nut

To order with 'GRIPPER' nut, add 'G' to the end of the part # (Except where noted!) Example: 1568x4x4G or 1568Px4x4G

## Bulkhead Union

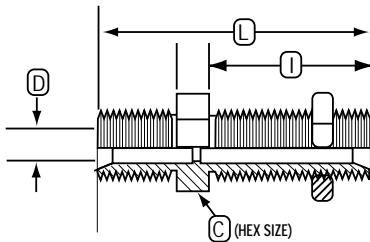
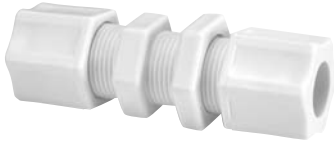

Tube O.D.	Catalog Number Nylon	Catalog Number Polypropylene	L	I	D	Hex C
1/4	1574x4	1574Px4	1.45	.88	.26	5/8
5/16	1574x5	1574Px5	1.63	.98	.32	11/16
3/8	1574x6	1574Px6	1.78	1.0	.38	13/16
1/2	1574x8	1574Px8	1.89	1.1	.51	15/16
3/4	1574x12G <sup>■</sup>	1574Px12G <sup>■</sup>	2.41	1.4	.76	1-5/16

## Female Connector

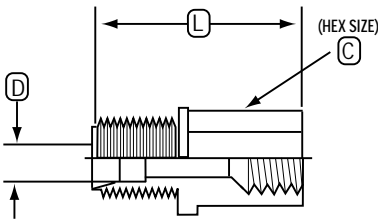

Tube O.D.	Pipe Thread	Catalog Number Nylon	Catalog Number Polypropylene	L	D	Hex C
1/4	1/8	1566x4	1566Px4	.92	.26	9/16
1/4	1/4	1566x4x4	1566Px4x4	1.09	.26	11/16
5/16	1/4	1566x5x4	1566Px5x4	1.22	.32	11/16
3/8	1/4	1566x6	1566Px6	1.20	.38	11/16
3/8	3/8	1566x6x6	1566Px6x6	1.20	.38	13/16
3/8	1/2	1566x6x8	1566Px6x8	1.27	.38	1-3/64
1/2	3/8	1566x8	1566Px8	1.23	.51	13/16
1/2	1/2	1566x8x8	1566Px8x8	1.30	.51	15/16
5/8	1/2	1566x10G <sup>■</sup>	1566Px10G <sup>■</sup>	1.50	.63	1-1/16

## Male Elbow

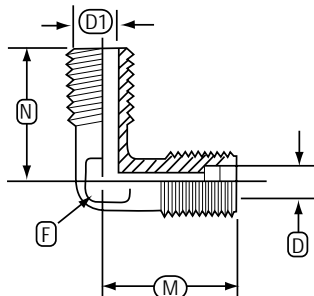

Tube O.D.	Pipe Thread	Catalog Number Nylon	Catalog Number Polypropylene	M	N	D	D1	Across Flats F
1/8	1/8	1569x2 <sup>■</sup>	1569Px2 <sup>■</sup>	.56	.63	.13	.20	1/4
1/4	1/8	1569x4	1569Px4	.81	.81	.26	.25	3/8
1/4	1/4	1569x4x4	1569Px4x4	.81	1.02	.26	.28	3/8
1/4	3/8	1569x4x6	1569Px4x6	.84	1.09	.26	.38	9/16
5/16	1/8	1569x5	1569Px5	.89	.906	.32	.25	7/16
5/16	1/4	1569x5x4	1569Px5x4	.91	1.08	.32	.23	7/16
3/8	1/4	1569x6	1569Px6	.94	1.03	.38	.31	37/64
3/8	3/8	1569x6x6	1569Px6x6	.94	1.09	.38	.38	9/16
1/2	1/4	1569x8x4G <sup>■</sup>	1569Px8x4G <sup>■</sup>	1.06	1.09	.51	.31	11/16
1/2	3/8	1569x8	1569Px8	1.09	1.13	.51	.31	11/16
1/2	1/2	1569x8x8	1569Px8x8	1.09	1.28	.51	.36	11/16
5/8	3/8	1569x10x6G <sup>■</sup>	1569Px10x6G <sup>■</sup>	1.25	1.25	.63	.38	27/32
5/8	1/2	1569x10G <sup>■</sup>	1569Px10G <sup>■</sup>	1.25	1.44	.63	.50	13/16

<sup>■</sup>Sold ONLY with GRIPPER style nut



# Molded Compression Tube Fittings

Plastic Fittings

## Female Elbow

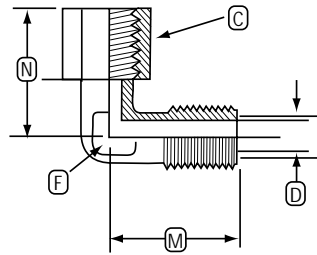

Tube O.D.	Pipe Thread	Catalog Number Nylon	Catalog Number Polypropylene	M	N	D	Hex C	Across Flats F
1/8	1/4	1570x2x4*	1570Px2x4*	.81	.97	.13	43/64	23/64
1/4	1/8	1570x4	1570Px4	.81	.75	.26	35/64	25/64
1/4	1/4	1570x4x4	1570Px4x4	.81	.97	.26	11/16	13/32
5/16	1/4	1570x5	1570Px5	.94	1.00	.32	11/16	7/16
3/8	1/4	1570x6	1570Px6	.94	1.02	.38	51/64	37/64
3/8	3/8	1570x6x6	1570Px6x6	.91	1.03	.38	13/16	9/16
1/2	3/8	1570x8	1570Px8	1.09	1.13	.51	51/64	23/32
1/2	1/2	1570x8x8	1570Px8x8	1.09	1.34	.51	15/16	23/32
5/8	1/2	1570x10G*	1570Px10G*	1.38	1.06	.63	1-1/16	53/64

## Union Elbow

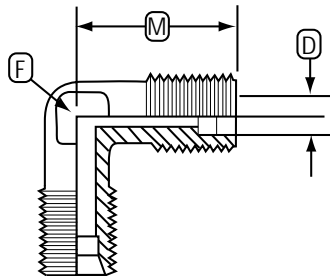

Tube O.D.	Catalog Number Nylon	Catalog Number Polypropylene	M	D	Across Flats F
1/4	1565x4	1565Px4	.81	.26	3/8
5/16	1565x5*	1565Px5G*	.91	.32	7/16
3/8	1565x6	1565Px6	.94	.38	9/16
1/2	1565x8	1565Px8	1.06	.51	43/64
5/8	1565x10G*	1565Px10G*	1.25	.63	13/16

## Male Branch Tee

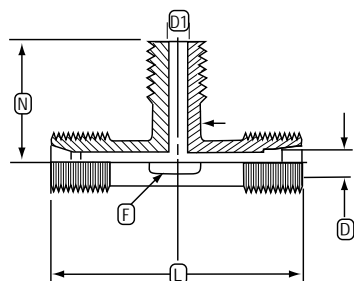

Tube O.D.	Pipe Thread	Catalog Number Nylon	Catalog Number Polypropylene	L	D	N	D1	Across Flats F
1/4	1/8	1572x4	1572Px4	1.45	.26	.75	.25	3/8
1/4	1/4	1572x4x4x4	1572Px4x4x4	1.45	.26	.92	.31	3/8
5/16	1/4	1572x5x5x4G*	1572Px5x5x4	1.61	.32	.98	.31	27/64
3/8	1/4	1572x6	1572Px6	1.91	.38	1.06	.31	31/64
3/8	3/8	1572x6x6x6	1572Px6x6x6G*	1.91	.38	1.11	.38	1/2
1/2	3/8	1572x8	1572Px8	2.19	.51	1.16	.38	39/64
1/2	1/2	1572x8x8x8	1572Px8x8x8	2.19	.51	1.31	.48	5/8
5/8	1/2	N/A	1572Px10G <sup>†</sup>	2.52	.63	1.44	.47	51/64
3/4	1/2	N/A	1572Px12G <sup>†</sup>	3.09	.76	1.61	.56	1-3/64
3/4	3/4	N/A	1572Px12x12x12G*	3.09	.76	1.63	.69	1-3/64

\*Not available with GRIPPER style nut    †Sold ONLY with GRIPPER style nut

PLASTIC

## Union Tee

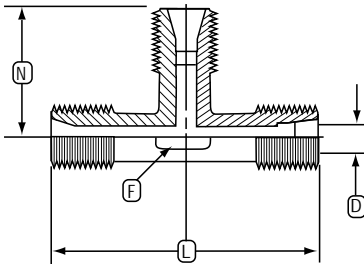

Tube O.D.	Catalog Number Nylon	Catalog Number Polypropylene	L	D	N	Across Flats F
1/8	1564x2*	1564Px2*	1.11	.13	.52	1/4
1/4	1564x4	1564Px4	1.44	.26	.72	23/64
5/16	1564x5	1564Px5	1.61	.32	.83	7/16
3/8	1564x6	1564Px6	1.91	.38	.97	17/32
1/2	1564x8	1564Px8	2.13	.51	1.03	11/16
5/8	1564x10G*	1564Px10G*	2.56	.63	1.25	13/16
3/4	1564x12G*	1564Px12G*	3.11	.76	1.56	1-1/16

## Male Run Tee

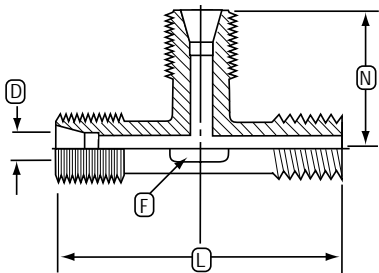

Tube O.D.	Pipe Thread	Catalog Number Nylon	Catalog Number Polypropylene	L	D	N	Across Flats F
1/4	1/8	1571x4	1571Px4	1.47	.26	.73	3/8
1/4	1/4	1571x4x4x4	1571Px4x4x4	1.67	.26	.72	23/64
5/16	1/4	1571x5x4x5G*	1571Px5x4x5	1.81	.32	.81	7/16
3/8	1/4	1571x6	1571Px6	1.98	.38	.95	31/64
3/8	3/8	1571x6x6x6	1571Px6x6x6	2.03	.38	.97	1/2
1/2	3/8	1571x8	1571Px8	2.27	.51	1.11	5/8
1/2	1/2	1571x8x8x8G*	1571Px8x8x8G*	2.41	.51	1.11	39/64
5/8	1/2	1571x10G*	1571Px10G*	2.72	.63	1.25	3/4
3/4	1/2	N/A	1571Px12G*	3.17	.76	1.55	1-1/16

## Compression Nut

Ferrule Nuts with Integral Sleeve

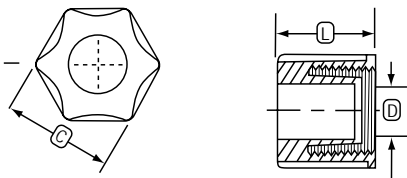

With Plastic Gripper

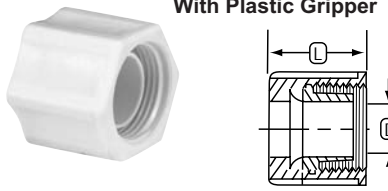

Tube O.D.	Catalog Number Nylon	Catalog Number Polypropylene	Hex C	L	D
1/8	1561x2	1561Px2	7/16	.52	.13
1/4	1561x4	1561Px4	5/8	.63	.26
5/16	1561x5	1561Px5	11/16	.69	.32
3/8	1561x6	1561Px6	13/16	.75	.38
1/2	1561x8	1561Px8	15/16	.88	.51
1/4	1561x4G	1561Px4G	5/8	.69	.26
5/16	1561x5G	1561Px5G	11/16	.75	.32
3/8	1561x6G	1561Px6G	13/16	.73	.38
1/2	1561x8G	1561Px8G	15/16	.88	.51
5/8	1561x10G	1561Px10G	1-1/8	.88	.63
3/4	1561x12G	1561Px12G	1-5/16	1.00	.76

\*Not available with GRIPPER style nut    \*Sold ONLY with GRIPPER style nut

# Molded Compression Tube Fittings

Plastic Fittings

## Insert

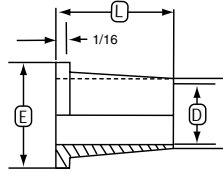

Tube O.D.	Catalog Number Nylon	Catalog Number Polypropylene	E	L	D
1/4	1584x4	1584Px4	.25	.38	.12
5/16	1584x5	1584Px5	.31	.40	.14
3/8	1584x6	1584Px6	.37	.50	.20
1/2	1584x8	1584Px8	.49	.56	.30

## Cap Nut

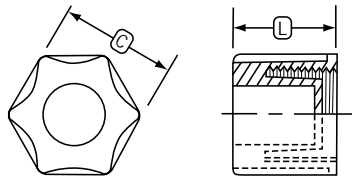

Tube O.D.	Catalog Number Nylon	Catalog Number Polypropylene	L	Hex C
1/8	1529x2	1529Px2	.52	7/16
1/4	1529x4	1529Px4	.63	5/8
5/16	1529x5	1529Px5	.70	45/64
3/8	1529x6	1529Px6	.73	13/16
1/2	1529x8	1529Px8	.88	15/16

## Bulkhead Nut

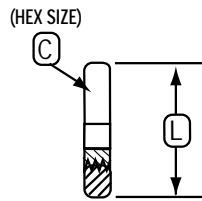

Tube O.D.	Catalog Number Nylon	Catalog Number Polypropylene	Hex C
1/4	1502x4	1502Px4	5/8
5/16	1502x5	1502Px5	11/16
3/8	1502x6	1502Px6	13/16
1/2	1502x8	1502Px8	15/16
3/4	1502x12	1502Px12	1-5/16

## KYNAR® Check Valve

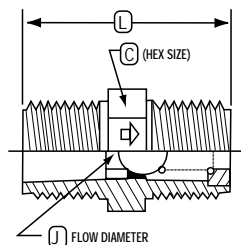

Male Pipe Size N.P.T.F.	Catalog Number KYNAR Only	L	J	Hex C
1/8	1531x2	1.00	.09	7/16
1/4	1531x4	1.41	.19	5/8
3/8	1531x6	1.50	.25	13/16
1/2	1531x8	1.81	.34	15/16

### KYNAR®\*\*\* Check Valve features and benefits:

- Viton® "O" Ring
- Stainless Ball & Spring
- Zero Leakage
- Maximum Operating Temp. 180°F @ 220 PSI
- Cracking Pressure 1 to 2.5 PSI

\*\* KYNAR® is a registered trademark of Elf Atochem North America, Inc. Viton® is a registered trademark of DuPont Dow Elastomers

 Refer to safety information regarding tubing selection on page 1.

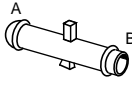
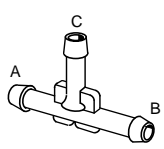
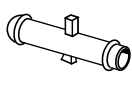
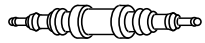
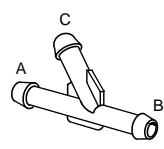
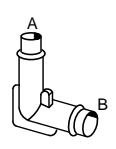
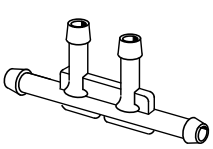
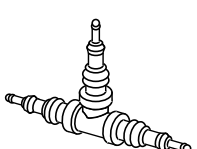
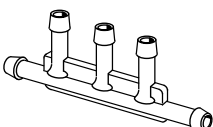
<p><b>Straight Connector</b></p> 	<table border="1"> <thead> <tr> <th>Tube I.D. A</th> <th>Tube I.D. B</th> <th>Catalog Number</th> </tr> </thead> <tbody> <tr><td>1/8</td><td>1/8</td><td>1911</td></tr> <tr><td>1/8</td><td>3/16</td><td>1923</td></tr> <tr><td>1/8</td><td>1/4</td><td>1924</td></tr> <tr><td>3/16</td><td>3/16</td><td>1912</td></tr> <tr><td>1/4</td><td>3/16</td><td>1914</td></tr> <tr><td>1/4</td><td>1/4</td><td>1913</td></tr> <tr><td>1/4</td><td>3/8</td><td>1915</td></tr> <tr><td>5/16</td><td>5/16</td><td>1925</td></tr> <tr><td>3/8</td><td>3/8</td><td>1927</td></tr> </tbody> </table>	Tube I.D. A	Tube I.D. B	Catalog Number	1/8	1/8	1911	1/8	3/16	1923	1/8	1/4	1924	3/16	3/16	1912	1/4	3/16	1914	1/4	1/4	1913	1/4	3/8	1915	5/16	5/16	1925	3/8	3/8	1927	<p><b>3 Way Tee</b></p>  <table border="1"> <thead> <tr> <th>Tube I.D. A</th> <th>Tube I.D. B</th> <th>Tube I.D. C</th> <th>Catalog Number</th> </tr> </thead> <tbody> <tr><td>1/8</td><td>1/8</td><td>1/8</td><td>1916</td></tr> <tr><td>1/8</td><td>1/8</td><td>3/16</td><td>1917</td></tr> <tr><td>1/8</td><td>1/8</td><td>1/4</td><td>1918</td></tr> <tr><td>1/8</td><td>3/16</td><td>1/8</td><td>1939</td></tr> <tr><td>3/16</td><td>1/8</td><td>3/16</td><td>1940</td></tr> <tr><td>3/16</td><td>3/16</td><td>3/16</td><td>1902</td></tr> <tr><td>3/16</td><td>3/16</td><td>1/8</td><td>1920</td></tr> <tr><td>3/16</td><td>3/16</td><td>1/4</td><td>1921</td></tr> <tr><td>1/4</td><td>3/16</td><td>3/16</td><td>1942</td></tr> <tr><td>1/4</td><td>1/4</td><td>1/4</td><td>1903</td></tr> <tr><td>1/4</td><td>1/4</td><td>3/16</td><td>1943</td></tr> <tr><td>5/16</td><td>5/16</td><td>5/16</td><td>1906</td></tr> <tr><td>3/8</td><td>3/16</td><td>3/8</td><td>1944</td></tr> <tr><td>3/8</td><td>1/4</td><td>3/8</td><td>1945</td></tr> <tr><td>3/8</td><td>5/16</td><td>3/8</td><td>1946</td></tr> <tr><td>3/8</td><td>3/8</td><td>3/16</td><td>1907</td></tr> <tr><td>3/8</td><td>3/8</td><td>1/4</td><td>1908</td></tr> <tr><td>3/8</td><td>3/8</td><td>3/8</td><td>1922</td></tr> </tbody> </table>	Tube I.D. A	Tube I.D. B	Tube I.D. C	Catalog Number	1/8	1/8	1/8	1916	1/8	1/8	3/16	1917	1/8	1/8	1/4	1918	1/8	3/16	1/8	1939	3/16	1/8	3/16	1940	3/16	3/16	3/16	1902	3/16	3/16	1/8	1920	3/16	3/16	1/4	1921	1/4	3/16	3/16	1942	1/4	1/4	1/4	1903	1/4	1/4	3/16	1943	5/16	5/16	5/16	1906	3/8	3/16	3/8	1944	3/8	1/4	3/8	1945	3/8	5/16	3/8	1946	3/8	3/8	3/16	1907	3/8	3/8	1/4	1908	3/8	3/8	3/8	1922
Tube I.D. A	Tube I.D. B	Catalog Number																																																																																																										
1/8	1/8	1911																																																																																																										
1/8	3/16	1923																																																																																																										
1/8	1/4	1924																																																																																																										
3/16	3/16	1912																																																																																																										
1/4	3/16	1914																																																																																																										
1/4	1/4	1913																																																																																																										
1/4	3/8	1915																																																																																																										
5/16	5/16	1925																																																																																																										
3/8	3/8	1927																																																																																																										
Tube I.D. A	Tube I.D. B	Tube I.D. C	Catalog Number																																																																																																									
1/8	1/8	1/8	1916																																																																																																									
1/8	1/8	3/16	1917																																																																																																									
1/8	1/8	1/4	1918																																																																																																									
1/8	3/16	1/8	1939																																																																																																									
3/16	1/8	3/16	1940																																																																																																									
3/16	3/16	3/16	1902																																																																																																									
3/16	3/16	1/8	1920																																																																																																									
3/16	3/16	1/4	1921																																																																																																									
1/4	3/16	3/16	1942																																																																																																									
1/4	1/4	1/4	1903																																																																																																									
1/4	1/4	3/16	1943																																																																																																									
5/16	5/16	5/16	1906																																																																																																									
3/8	3/16	3/8	1944																																																																																																									
3/8	1/4	3/8	1945																																																																																																									
3/8	5/16	3/8	1946																																																																																																									
3/8	3/8	3/16	1907																																																																																																									
3/8	3/8	1/4	1908																																																																																																									
3/8	3/8	3/8	1922																																																																																																									
<p><b>Restrictor Connector</b></p> 	<table border="1"> <thead> <tr> <th>Tube I.D. Size</th> <th>Catalog Number</th> </tr> </thead> <tbody> <tr> <td>3/16</td> <td>1950</td> </tr> </tbody> </table>	Tube I.D. Size	Catalog Number	3/16	1950																																																																																																							
Tube I.D. Size	Catalog Number																																																																																																											
3/16	1950																																																																																																											
<p><b>Universal Connector</b></p> 	<table border="1"> <thead> <tr> <th>Tube I.D. Size</th> <th>Catalog Number</th> </tr> </thead> <tbody> <tr> <td>5/32–1/4–3/8</td> <td>1901</td> </tr> </tbody> </table>	Tube I.D. Size	Catalog Number	5/32–1/4–3/8	1901	<p><b>Y Connector</b></p>  <table border="1"> <thead> <tr> <th>Tube I.D. A</th> <th>Tube I.D. B</th> <th>Tube I.D. C</th> <th>Catalog Number</th> </tr> </thead> <tbody> <tr><td>3/16</td><td>3/16</td><td>3/16</td><td>1932</td></tr> <tr><td>1/4</td><td>1/4</td><td>3/16</td><td>1933</td></tr> <tr><td>1/4</td><td>1/4</td><td>1/4</td><td>1935</td></tr> <tr><td>1/4</td><td>3/8</td><td>3/8</td><td>1936</td></tr> <tr><td>5/16</td><td>5/16</td><td>5/16</td><td>1937</td></tr> <tr><td>3/8</td><td>3/8</td><td>3/8</td><td>1938</td></tr> </tbody> </table>	Tube I.D. A	Tube I.D. B	Tube I.D. C	Catalog Number	3/16	3/16	3/16	1932	1/4	1/4	3/16	1933	1/4	1/4	1/4	1935	1/4	3/8	3/8	1936	5/16	5/16	5/16	1937	3/8	3/8	3/8	1938																																																																										
Tube I.D. Size	Catalog Number																																																																																																											
5/32–1/4–3/8	1901																																																																																																											
Tube I.D. A	Tube I.D. B	Tube I.D. C	Catalog Number																																																																																																									
3/16	3/16	3/16	1932																																																																																																									
1/4	1/4	3/16	1933																																																																																																									
1/4	1/4	1/4	1935																																																																																																									
1/4	3/8	3/8	1936																																																																																																									
5/16	5/16	5/16	1937																																																																																																									
3/8	3/8	3/8	1938																																																																																																									
<p><b>Elbow Connector</b></p> 	<table border="1"> <thead> <tr> <th>Tube I.D. A</th> <th>Tube I.D. B</th> <th>Catalog Number</th> </tr> </thead> <tbody> <tr><td>1/8</td><td>3/16</td><td>1928</td></tr> <tr><td>3/16</td><td>3/16</td><td>1929</td></tr> <tr><td>3/16</td><td>1/4</td><td>1930</td></tr> <tr><td>1/4</td><td>1/4</td><td>1931</td></tr> </tbody> </table>	Tube I.D. A	Tube I.D. B	Catalog Number	1/8	3/16	1928	3/16	3/16	1929	3/16	1/4	1930	1/4	1/4	1931	<p><b>4 Way Tee</b></p>  <table border="1"> <thead> <tr> <th>Tube I.D. All Ends</th> <th>Catalog Number</th> </tr> </thead> <tbody> <tr> <td>3/16</td> <td>1948</td> </tr> </tbody> </table>	Tube I.D. All Ends	Catalog Number	3/16	1948																																																																																							
Tube I.D. A	Tube I.D. B	Catalog Number																																																																																																										
1/8	3/16	1928																																																																																																										
3/16	3/16	1929																																																																																																										
3/16	1/4	1930																																																																																																										
1/4	1/4	1931																																																																																																										
Tube I.D. All Ends	Catalog Number																																																																																																											
3/16	1948																																																																																																											
<p><b>Universal Tee</b></p> 	<table border="1"> <thead> <tr> <th>Tube I.D. Size</th> <th>Catalog Number</th> </tr> </thead> <tbody> <tr> <td>5/32–1/4–3/8</td> <td>1900</td> </tr> </tbody> </table>	Tube I.D. Size	Catalog Number	5/32–1/4–3/8	1900	<p><b>5 Way Tee</b></p>  <table border="1"> <thead> <tr> <th>Tube I.D. All Ends</th> <th>Catalog Number</th> </tr> </thead> <tbody> <tr> <td>3/16</td> <td>1949</td> </tr> </tbody> </table>	Tube I.D. All Ends	Catalog Number	3/16	1949																																																																																																		
Tube I.D. Size	Catalog Number																																																																																																											
5/32–1/4–3/8	1900																																																																																																											
Tube I.D. All Ends	Catalog Number																																																																																																											
3/16	1949																																																																																																											

Not recommended for fuel line applications. Temperature Range: -40°F to +350°F. Material: Nylon 6/6

### Materials

All Weatherhead Fittings are available in a variety of alloys on special order.

**Carbon Steel Fittings** – are precision machined from AISI 12L14 carbon steel. Shaped fittings such as elbows and tees with a “C” prefix are made from high-density forgings. Shaped fittings with a “TF” prefix are brazed. Straight fittings are from bar stock.

**Stainless Steel Fittings** – are made from type 316 stainless. Standard Ermeto® flareless sleeves are made from 17-4PH precipitation hardened stainless.

### Finishes

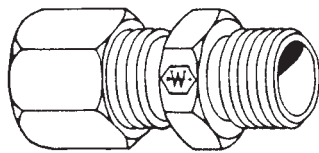

**Weathercote™** – is an exclusive Weatherhead® trademark for a protective coating that far exceeds the minimum requirements of the SAE specifications for a corrosion resistant finish for use with petroleum-based, synthetic, and water-based hydraulic fluids. It is readily identified by its dark appearance. Weathercote™ is an amorphous phosphate coating covered with a soluble rust-proof film resulting in a coating

of .0002” thick, yet providing full protection against electrolytic action, thread seizure or corrosive action of hydraulic fluids.

The lubricity of the rust-proof solvent film measurably reduces the amount of torque required to make leak-proof connections.

**Zinc Plated** – Weatherhead® fittings are given an electrolytic coating .0002” thick minimum.

**Stainless Steel** – fittings are supplied with natural surface finish except tube nuts which are coated with a bonded dry-film lubricant (black) to reduce assembly torque and prevent galling of threads. All Weatherhead® Stainless Steel Fittings are passivated to remove microscopic foreign particles from the surface of stainless steel as required. Process also leaves a film of corrosion protection.

### Hydraulic Fluids

Modern hydraulic systems in use today employ a wide variety of high quality hydraulic fluids. There are three principle types in general use today – each best suited for particular conditions. They are discussed here briefly to clarify the fitting finishes compatible with each type.

### Petroleum or Mineral Oil Based

**Hydraulic Fluids** – are good general purpose fluids available in a full range of viscosity specified as SAE 10, 20, 30, etc. These fluids are not fire resistant, making them unsuitable for use where there is a potential source of ignition. ALL Weatherhead® fittings and O-rings can be used with these fluids.

**Straight Synthetic Hydraulic Fluids** – is a general term applied to such products as Pydraul, Lindol, Cellulubes 90, 150, 180, 220, etc. used where fire hazards are high. Weathercote™ finish fittings are recommended for this type of fluid. O-rings MUST be made of a “Butyl” compound, or they will “swell” when contacted by synthetic fluids.

**Water-Based Hydraulic Fluids** – consist generally of a mixture of water and poly-glycols. They are non-flammable and serve the same purpose as the synthetic types. **Only Weathercote™ finish fittings are recommended for this type of fluid.** Zinc plate finishes will be dissolved by water-based fluids and damage to expensive components may result. These water-based fluids are usually less expensive than synthetic fluids and have little or no detrimental effects on Buna-N compounds used in o-rings.

## O-Ring Compound and Application Chart

O-Ring Catalog Number	Base Material of Compound	Petroleum & Mineral Oil-Based Hydraulic Fluids	Straight Synthetic Hydraulic Fluids	Water-Based Hydraulic Fluids (Poly-glycols)	Air	Water	Lubricating Oils	Durometer Hardness	Temperature Range °F
4629*	Buna-N	Excellent	Unsuitable	Good	Excellent	Good	Excellent	90	-40° to +250°
7629*	Buna-N	Excellent	Unsuitable	Good	Excellent	Good	Excellent	90	-40° to +250°

\*Standard O-ring complies with SAE J515 Type CH and ASTM specifications D2000.

All standard Weatherhead® straight thread fittings are supplied with this type O-ring, unless otherwise specified. (Viton O-Rings are available as special order items only).

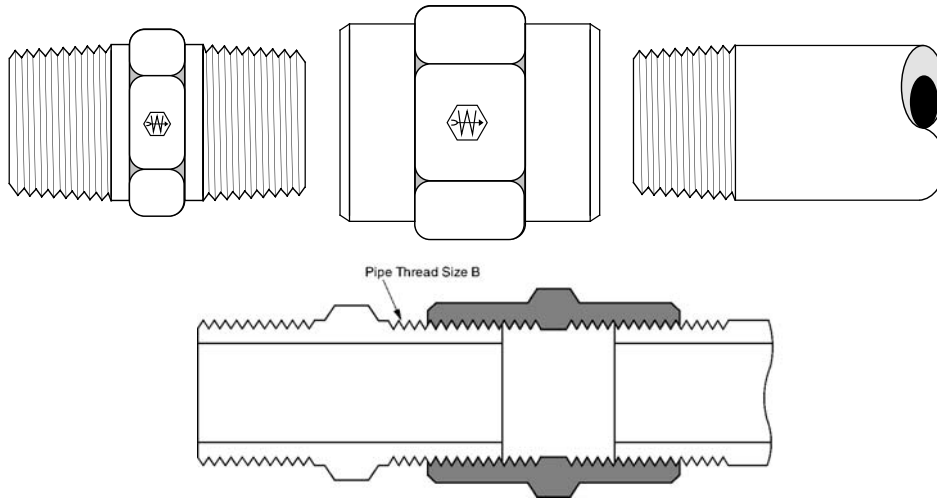

Pipe Size	1/16	1/8	1/4	3/8	1/2	3/4	1	1-1/4	1-1/2	2
Thread Size-B	1/16-27	1/8-27	1/4-18	3/8-18	1/2-14	3/4-14	1-11-1/2	1-1/4-11-1/2	1-1/2-11-1/2	2-11-1/2

### Forged Fittings and Adaptors

Pipe Fittings 3000 Series Pressure Rating Chart

Connection Type	End Size								
	1/8"	1/4"	3/8"	1/2"	3/4"	1"	1-1/4"	1-1/2"	2"
Male Pipe (NPTF)	6000	5000	5000	4000	4000	4000	3000	2500	2500
Femlae Pipe (NPTF)	5000	5000	4000	3000	2500	2000	1500	1500	1000

### Brazed Fittings (TF)

Pipe Fittings 3000 Series Pressure Rating Chart

Connection Type	End Size								
	1/8"	1/4"	3/8"	1/2"	3/4"	1"	1-1/4"	1-1/2"	2"
Male Pipe (NPTF)	5000	5000	4000	3000	2500	2000	1150	1000	1000
Femlae Pipe (NPTF)	5000	5000	4000	3000	2500	2050	1500	1000	1000

Rated pressures are for low surge, static type applications.

- Typical Application**  
 Grease, instrumentation and most hydraulic systems.
- Pressure**  
 Refer to the pressure charts above. The maximum working pressure of an adapter is the lower working pressure of the end size. Ex: C3069x8x6, 8 = 4000 psi and 6 = 5000 psi. Maximum working pressure is 4000 psi.
- Vibration**  
 Fair resistance.
- Temperature Range**  
 -65°F to +400°F (-53°C to +204°C).
- Material**  
 Carbon Steel - AISI/SAE 12L14  
 Stainless Steel - type 316  
 Plating - Zinc, yellow dichromate finish ASTM B633 Type II.
- Used With**  
 Steel, brass, bronze and iron pipe.
- Advantages**  
 Dryseal pipe threads (NPTF) (SAE J476), zinc plate, compact size. Broad range of sizes and styles.
- Conformance**  
 Meets SAE specifications.
- How to Order**  
 Order individually by catalog number. Example: C3069x4. To order with Weathercote finish (black phosphate coating), use "W" prefix in place of "C". Example: W3069x4 (special order only). To order with pipe sealant (Seal-A-Thread), add a "Z" suffix to the catalog number. Example: C3069x4Z (special order only).  
  
 Weatherhead fittings with a "C" prefix are made from a forged construction. Example: C3609x4. Weatherhead fittings with a "TF" prefix are made from a brazed construction. Example: TF3609x4.
- NOTE**  
 Refer to current price list for availability of cataloged items. Quotations and delivery of non-stock items supplied upon request. Configurations and dimensions subject to change without notice. Additional information can be found in SAE J514.
- Assembly Instructions**  
 Tighten approximately 2-1/2 turns past finger tight. On all shaped fittings, such as elbows and tees, tighten approximately 2 turns past finger tight and orientate the fitting on the third turn. **NOTE:** Backing off for orientation after completing the tightening process, may cause the thread sealing method on these pipe threads to leak!
- Welding procedures**  
 Use electric weldrod AWS-E7018. Recommended procedure specifies using lower amperage than usual and puddling of molten metal to permit gases created by lead in steel to work through molten lead deposit.

Label Set: **FS-2000** (adhesive)

## Seal-Nut

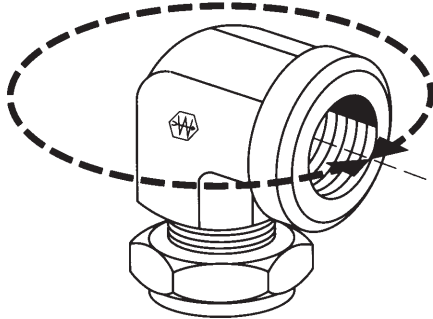

Teflon® is a registered trademark of DuPont.

### SPECIFICATIONS FOR "SEAL NUT"

- **Material:** All Weatherhead "Seal-Nuts" are precision machined from 12L14 steel; insert is made of molded virgin Teflon®.
- **Pressure:** Refer to pressure charts on previous page.
- **Temp. Range:** Designed to operate satisfactorily from -100°F to +500°F.
- Makes every pipe connection leakproof.
- Permits positioning of pipe elbows and tees full 360° without overtightening.
- Thread seal-nut on pipe thread. Tighten pipe elbows and tees to proper position, then tighten seal nut for positive seal.
- Eliminates leaks on all pipe threads – Dry Seal or standard. No pipe compound required. Quick, easy installations in cramped quarters where wrench clearance is limited.
- "Seal-Nuts" are an economical substitute for straight thread O-ring boss fittings using original female pipe ports. "Seal-Nuts" give you positive seal on directional fittings like tees and elbows without distorting mounting bosses or damaging expensive valves and pumps.
- **Assembly Instructions:**
  1. Thread Seal-Nut on to the pipe threads until 4 threads protrude beyond the Teflon seal.
  2. Thread fitting a minimum of 3 full threads into port. Continue turning fitting to desired position.
  3. Tighten seal-nut against the port with light to medium torque to provide a positive seal. Torque required will vary with application.

## Seal-Nut for Male Pipe Threads

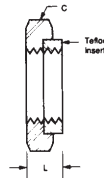

Pipe Thread	Catalog Number	Hex C	L
1/8	C3059x2	5/8	.15
1/4	C3059x4	3/4	.25
3/8	C3059x6	7/8	.25
1/2	C3059x8	1-1/8	.25
3/4	C3059x12	1-5/16	.25
1	C3059x16	1-5/8	.34

## Hex Socket Plug

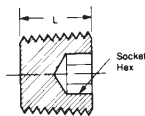
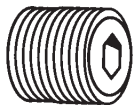

Male Pipe Thread	Catalog Number	Socket Hex	L
1/16	C3169x1	5/32	.31
1/8	C3169x2	3/16	.30
1/4	C3169x4	1/4	.46

## Square Head Plug

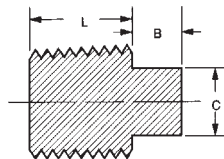
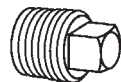

Male Pipe Thread	Catalog Number	B	C	L
1/8	C3179x2	.25	9/32	.34
1/4	C3179x4	.29	3/8	.51
3/8	C3179x6	.32	7/16	.51
1/2	C3179x8	.40	9/16	.68
3/4	C3179x12	.46	5/8	.69
1	C3179x16	.52	13/16	.85

## Hex Head Plug Stainless Steel No. 3171x

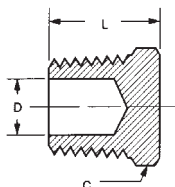
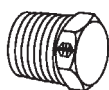

Male Pipe Thread	Catalog Number	Hex C	L	D Opt. Dia.
1/8	C3159x2	7/16	.56	.156
1/4	C3159x4	9/16	.68	.250
3/8	C3159x6	11/16	.78	.375
1/2	C3159x8	7/8	.98	.500
3/4	C3159x12	1-1/8	1.06	.690
1	C3159x16	1-3/8	1.25	.875
1-1/4	C3159x20	1-3/4	1.56	–
1-1/2	C3159x24	2	1.62	–
2	C3159x32	2-1/2	1.75	–

STEEL

## Bushing Stainless Steel No. 3121x (Ref. SAE No. 140140)

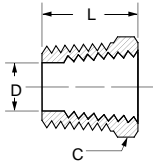
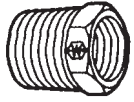

Male Pipe Thread	Fem. Pipe Thread	Catalog Number	Hex C	D	L
1/4	1/8	C3109x4x2	5/8	.322	.85
3/8	1/8	C3109x6x2	3/4	.332	.85
3/8	1/4	C3109x6x4	3/4	.438	.85
1/2	1/8	C3109x8x2	7/8	.332	1.10
1/2	1/4	C3109x8x4	7/8	.438	1.10
1/2	3/8	C3109x8x6	7/8	.562	1.10
3/4	1/4	C3109x12x4	1-1/8	.438	1.17
3/4	3/8	C3109x12x6	1-1/8	.562	1.17
3/4	1/2	C3109x12x8	1-1/8	.703	1.17
1	3/8	C3109x16x6	1-3/8	.562	1.36
1	1/2	C3109x16x8	1-3/8	.703	1.36
1	3/4	C3109x16x12	1-3/8	.922	1.36
1-1/4	1/2	C3109x20x8	1-3/4	.703	1.47
1-1/4	3/4	C3109x20x12	1-3/4	.922	1.47
1-1/4	1	C3109x20x16	1-3/4	1.156	1.47
1-1/2	3/4	C3109x24x12	2	.906	1.58
1-1/2	1	C3109x24x16	2	1.141	1.58
1-1/2	1-1/4	C3109x24x20	2	1.500	1.57
2	1-1/4	C3109x32x20	2-1/2	1.484	1.75
2	1-1/2	C3109x32x24	2-1/2	1.719	1.75

## Straight Thread O-Ring to Female Pipe Adapter

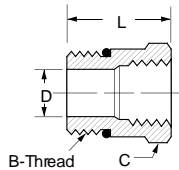
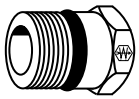

Male Port Size	Fem. Pipe Thread	Catalog Number	Straight Thread B	Hex C	D	L
1/4	1/8	C3269x4x2	7/16-20	9/16	.172	.97
1/4	1/4	C3269x4x4	7/16-20	3/4	.172	1.16
5/16	1/8	C3269x5x2	1/2-20	5/8	.234	.94
3/8	1/4	C3269x6x4	9/16-18	3/4	.297	1.09
3/8	3/8	C3269x6x6	9/16-18	7/8	.281	1.30
3/8	1/2	C3269x6x8	9/16-18	1-1/8	.281	1.44
1/2	1/4	C3269x8x4	3/4-16	7/8	.421	1.06
1/2	3/8	C3269x8x6	3/4-16	7/8	.421	1.22
1/2	1/2	C3269x8x8	3/4-16	1-1/16	.421	1.50
5/8	1/4	C3269x10x4	7/8-14	1	.422	.81
5/8	3/8	C3269x10x6	7/8-14	1	.500	1.25
5/8	1/2	C3269x10x8	7/8-14	1-1/8	.500	1.50
5/8	3/4	C3269x10x12	7/8-14	1-3/8	.500	1.62
3/4	1/2	C3269x12x8	1-1/16-12	1-1/4	.688	1.34
3/4	3/4	C3269x12x12	1-1/16-12	1-3/8	.656	1.66
7/8	3/4	C3269x14x12	1-3/16-12	1-3/8	.718	1.63
1	1/2	C3269x16x8	1-5/16-12	1-1/2	.688	1.00
1	3/4	C3269x16x12	1-5/16-12	1-1/2	.876	1.50
1	1	C3269x16x16	1-5/16-12	1-5/8	.876	1.88
1-1/4	1	C3269x20x16	1-5/8-12	1-7/8	1.080	1.00
1-1/4	1-1/4	C3269x20x20	1-5/8-12	2	1.080	1.94
1-1/2	1-1/2	C3269x24x24	1-7/8-12	2-3/8	1.312	1.88
2	2	C3269x32x32	2-1/2-12	2-7/8	1.781	1.91

Replacement o-rings page 148.

## Adapter Stainless Steel No. 3221x (Ref. SAE 140139)

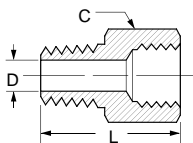
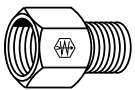

Fem. Pipe Thread	Male Pipe Thread	Catalog Number	Hex C	D	L
1/4	1/8	C3209x4x2	3/4	.188	1.21
3/8	1/4	C3209x6x4	7/8	.281	1.44
1/2	1/8	C3209x8x2	1-1/8	.188	1.50
1/2	1/4	C3209x8x4	1-1/8	.281	1.68
1/2	3/8	C3209x8x6	1-1/8	.406	1.68
3/4	1/4	C3209x12x4	1-3/8	.281	1.78
3/4	1/2	C3209x12x8	1-3/8	.531	1.93
1	1/2	C3209x16x8	1-5/8	.562	2.09
1	3/4	C3209x16x12	1-5/8	.719	2.18
1-1/4	1	C3209x20x16	2	.938	2.46
1-1/2	1-1/4	C3209x24x20	2-3/8	1.25	2.50
2	1-1/2	C3209x32x24	2-7/8	1.500	2.63



### Female Straight Thread O-Ring to Male Pipe Adapter

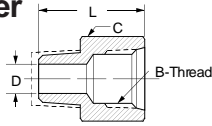
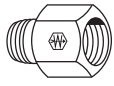

Fem. Port Size	Male Pipe Thread	Catalog Number	Straight Thread B	Hex C	D	L
3/8	3/8	C3239x6x6	9/16-18	13/16	.406	1.38
3/8	1/2	C3239x6x8	9/16-18	7/8	.500	1.61
1/2	3/8	C3239x8x6	3/4-16	1	.406	1.46
1/2	1/2	C3239x8x8	3/4-16	1	.562	1.69
5/8	1/2	C3239x10x8	7/8-14	1-1/4	.531	1.81

### Coupling Stainless Steel No. 3321x (Ref. SAE No. 140138)

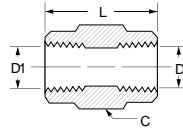
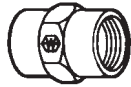

Fem. Pipe Thread	Fem. Pipe Thread	Catalog Number	Hex C	D	D1	L
1/8	1/8	C3309x2	5/8	.332	.332	.75
1/4	1/8	C3309x4x2	3/4	.437	.332	1.13
1/4	1/4	C3309x4	3/4	.437	.437	1.13
3/8	1/4	C3309x6x4	7/8	.562	.437	1.13
3/8	3/8	C3309x6	7/8	.562	.562	1.13
1/2	1/4	C3309x8x4	1-1/8	.687	.437	1.50
1/2	3/8	C3309x8x6	1-1/8	.687	.562	1.50
1/2	1/2	C3309x8	1-1/8	.687	.687	1.50
3/4	1/2	C3309x12x8	1-3/8	.906	.687	1.53
3/4	3/4	C3309x12	1-3/8	.906	.906	1.53
1	3/4	C3309x16x12	1-5/8	1.125	.906	1.89
1	1	C3309x16	1-5/8	1.125	1.125	1.89
1-1/4	1-1/4	C3309x20	2	1.468	1.468	1.93
1-1/2	1-1/2	C3309x24	2-3/8	1.703	1.703	1.93
2	2	C3309x32	2-7/8	2.188	2.188	1.96

### Hex Nipple Stainless Steel No. 3081x (Ref. SAE No. 140137)

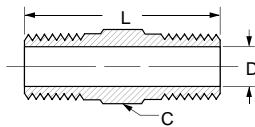

Male Pipe Thread	Male Pipe Thread	Catalog Number	Hex C	D	L
1/16	1/16	C3069x1	5/16	.141	.940
1/8	1/16	C3069x2x1	7/16	.141	.970
1/8	1/8	C3069x2	7/16	.188	1.06
1/4	1/8	C3069x4x2	5/8	.188	1.26
1/4	1/4	C3069x4	5/8	.281	1.45
3/8	1/8	C3069x6x2	3/4	.188	1.26
3/8	1/4	C3069x6x4	3/4	.281	1.45
3/8	3/8	C3069x6	3/4	.406	1.45
1/2	1/4	C3069x8x4	7/8	.281	1.70
1/2	3/8	C3069x8x6	7/8	.406	1.70
1/2	1/2	C3069x8	7/8	.531	1.89
3/4	1/2	C3069x12x8	1-1/8	.531	1.96
3/4	3/4	C3069x12	1-1/8	.719	1.96
1	3/4	C3069x16x12	1-3/8	.719	2.16
1	1	C3069x16	1-3/8	.938	2.34
1-1/4	1-1/4	C3069x20	1-3/4	1.250	2.48
1-1/2	1-1/2	C3069x24	2	1.500	2.61
2	2	C3069x32	2-1/2	1.938	2.83

### Male For-Seal® to Male Pipe Adapter

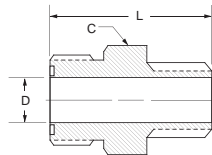
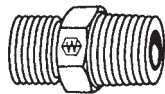

Tube O.D.	Male Pipe Thread	Catalog Number	Hex C	D	D1	L
1/4	1/8	4205x4•	5/8	.172	.188	1.08
3/8	1/4	4205x6•	3/4	.264	.281	1.34
3/8	3/8	4205x6x6	3/4	.264	.406	1.30
1/2	3/8	4205x8	7/8	.378	.406	1.45
1/2	1/2	4205x8x8	7/8	.378	.484	1.64
5/8	1/2	4205x10	1-1/16	.484	.531	1.82
3/4	1/2	4205x12x8	1-1/4	.406	.484	1.87
3/4	3/4	4205x12	1-1/4	.609	.719	1.94
3/4	1	4205x12x16	1-3/8	.609	.938	1.87
1	1	4205x16	1-1/2	.811	.938	2.19
1-1/4	1-1/4	4205x20	1-3/4	1.024	1.250	2.30

### Male Straight Thread O-Ring to Male Pipe Adapter

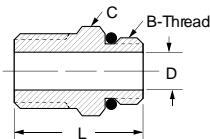

Male Port Size	Male Pipe Size	Catalog Number	Straight Thread B	Hex C	D	L
1/4	1/8	C3249x4x2	7/16-20	9/16	.172	1.05
3/8	1/4	C3249x6x4	9/16-18	11/16	.281	1.30
1/2	3/8	C3249x8x6	3/4-16	7/8	.391	1.36
1/2	1/2	C3249x8x8	3/4-16	7/8	.391	1.55
5/8	1/2	C3249x10x8	7/8-14	1	.434	1.69
3/4	3/4	C3249x12x12	1-1/16-12	1-1/4	.609	1.73
1	1	C3249x16x16	1-5/16-12	1-1/2	.844	2.06
1-1/4	1-1/4	C3249x20x20	1-5/8-12	1-7/8	1.078	2.17
1-1/2	1-1/2	C3249x24x24	1-7/8-12	2-1/8	1.312	2.26
2	2	C3249x32x32	2-1/2-12	2-7/8	1.781	2.47

Replacement O-rings page 148.

STEEL

## Bulkhead Coupling

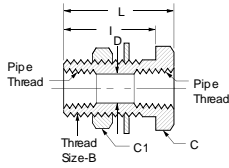
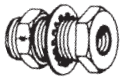

Fem. Pipe Thread	Catalog Number	Thread Size B	Hex C	Hex C1	D	I	L
1/4	<a href="#">W05465</a>	3/4-16	1	15/16	.422	1.25	1.50
1/4	<a href="#">W21204</a>	3/4-16	1	15/16	.422	.69	.94
3/8	<a href="#">W17709</a>	1-14	1-1/8	1-3/8	.563	1.06	1.31

## Bulkhead Coupling

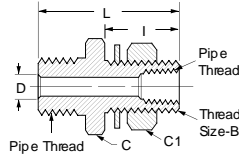

Male Pipe Thread	Fem. Pipe Thread	Catalog Number	Thread Size B	Hex C	Hex C1	D	I	L
1/2	1/4	<a href="#">W05498</a>	3/4-16	1-1/4	1-1/16	.312	1.13	2.16
1/2	1/4	<a href="#">W05499</a>	3/4-16	1-1/4	1-1/16	.312	1.53	2.53

## Bulkhead Coupling

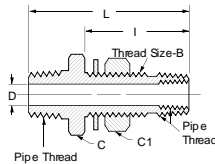
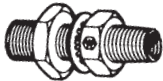

Male Pipe Thread	Fem. Pipe Thread	Catalog Number	Thread Size B	Hex C	Hex C1	D	I	L
1/2	1/4	<a href="#">W05730</a>	1-14	1-1/4	1-3/8	.375	1.91	2.94
1/2	1/4	<a href="#">W23464</a>	1-14	1-1/4	1-3/8	.375	2.88	3.94

## 45° Elbow (Ref. SAE No. 140338)

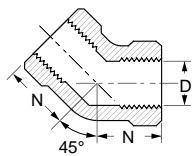
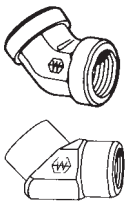

Fem. Pipe Thread	Catalog Number	D	N	Across Flats
1/8	<a href="#">C3559x2</a>	.332	.50	9/16
1/4	<a href="#">C3559x4</a>	.437	.69	3/4
3/8	<a href="#">C3559x6</a>	.562	.750	7/8
1/2	<a href="#">C3559x8</a>	.687	.940	1-1/16
3/4	<a href="#">C3559x12</a>	.906	1.000	1-5/16
1	<a href="#">C3559x16</a>	1.125	1.190	1-5/8
1-1/4	<a href="#">C3559x20</a>	1.468	1.44	1-7/8
1-1/2	<a href="#">C3559x24</a>	1.734	1.46	2-9/16
2	<a href="#">C3559x32</a>	2.188	1.59	2-13/16
1/4	<a href="#">TF3559x4</a>	.437	.620	3/4

## 45° Street Elbow Stainless Steel No. 3371x (Ref. SAE No. 140339)

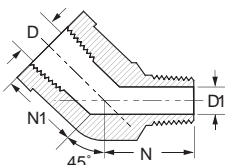
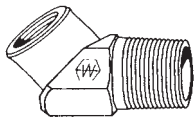
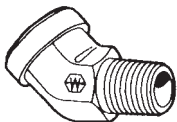

Fem. Pipe Thread	Male Pipe Thread	Catalog Number	D	D1	N1	N	Across Flats
1/8	1/8	<a href="#">C3359x2</a>	.332	.188	.47	.72	9/16
1/4	1/4	<a href="#">C3359x4</a>	.437	.281	.62	1.05	3/4
3/8	3/8	<a href="#">C3359x6</a>	.562	.406	.72	1.06	7/8
1/2	1/2	<a href="#">C3359x8</a>	.687	.531	.91	1.34	1-1/16
3/4	3/4	<a href="#">C3359x12</a>	.906	.719	.97	1.38	1-5/16
1	1	<a href="#">C3359x16</a>	1.125	.938	1.12	1.72	1-5/8
1/8	1/8	<a href="#">TF3359x2</a>	.332	.188	.47	.72	5/8
1/4	1/4	<a href="#">TF3359x4</a>	.437	.281	.62	1.05	3/4
3/8	3/8	<a href="#">TF3359x6</a>	.562	.406	.72	1.06	7/8
1/2	1/2	<a href="#">TF3359x8</a>	.687	.531	.91	1.34	1-1/8
3/4	3/4	<a href="#">TF3359x12</a>	.906	.719	.97	1.38	1-3/8
1	1	<a href="#">TF3359x16</a>	1.125	.938	1.12	1.72	1-5/8
1-1/4	1-1/4	<a href="#">TF3359x20</a>	1.468	1.250	1.63	1.80	2
1-1/2	1-1/2	<a href="#">TF3359x24</a>	1.734	1.500	1.69	2.06	2-3/8
2	2	<a href="#">TF3359x32</a>	2.188	1.938	2.30	2.15	2-1/2

**90° Elbow**  
**Stainless Steel No. 3521x**  
 (Ref. SAE No. 140238)

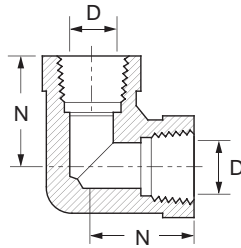
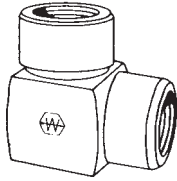

Fem. Pipe Thread	Fem. Pipe Thread	Catalog Number	D	N	Across Flats
1/8	1/8	C3509x2	.332	.66	9/16
1/4	1/4	C3509x4	.437	.88	3/4
3/8	3/8	C3509x6	.562	1.02	7/8
1/2	1/2	C3509x8	.687	1.23	1-1/16
3/4	3/4	C3509x12	.906	1.36	1-5/8
1	1	C3509x16	1.125	1.62	1-5/8
1-1/4	1-1/4	C3509x20	1.468	1.70	1-7/8
2	2	C3509x32	2.188	2.39	2-3/16
1/8	1/8	TF3509x2	.332	.66	5/8
1/4	1/8	TF3509x4x2	.437	.88	3/4
1/4	1/4	TF3509x4	.437	.88	3/4
3/8	1/4	TF3509x6x4	.437	1.02	7/8
3/8	3/8	TF3509x6	.562	1.02	7/8
1/2	3/8	TF3509x8x6	.562	1.23	1-1/8
1/2	1/2	TF3509x8	.687	1.23	1-1/8
3/4	1/2	TF3509x12x8	.687	1.23	1-3/8
3/4	3/4	TF3509x12	.906	1.36	1-3/8
1	1	TF3509x16	1.125	1.62	1-5/8
1-1/4	1-1/4	TF3509x20	1.468	1.70	2
1-1/2	1-1/2	TF3509x24	1.734	2.08	2-3/8

**90° Street Elbow**  
**Stainless Steel No. 3421x**  
 (Ref. SAE No. 140239)

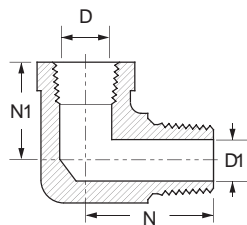
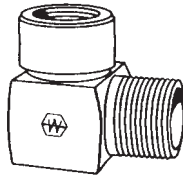
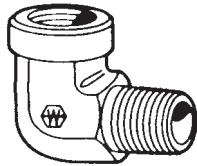

Male Pipe Thread	Fem. Pipe Thread	Catalog Number	D	D1	N	N1	Across Flats
1/8	1/8	C3409x2	.332	.188	.78	.66	9/16
1/4	1/4	C3409x4	.437	.281	1.09	.88	3/4
3/8	3/8	C3409x6	.562	.406	1.22	1.02	7/8
1/2	1/2	C3409x8	.687	.531	1.47	1.23	1-1/16
3/4	3/4	C3409x12	.906	.719	1.59	1.36	1-5/16
1	1	C3409x16	1.125	.938	1.97	1.62	1-5/8
1-1/4	1-1/4	C3409x20	1.468	1.250	2.38	1.70	1-7/8
2	2	C3409x32	2.188	1.930	3.00	2.39	2-13/16
1/8	1/8	TF3409x2	.332	.188	.78	.66	5/8
1/8	1/4	TF3409x2x4	.437	.188	.91	.88	3/4
1/4	1/8	TF3409x4x2	.332	.281	1.09	.67	5/8
1/4	1/4	TF3409x4	.437	.281	1.09	.88	3/4
1/4	3/8	TF3409x4x6	.562	.281	1.22	1.02	7/8
3/8	1/4	TF3409x6x4	.437	.406	1.22	.91	13/16
3/8	3/8	TF3409x6	.562	.406	1.22	1.02	7/8
3/8	1/2	TF3409x6x8	.687	.406	1.38	1.23	1-1/8
1/2	3/8	TF3409x8x6	.562	.531	1.47	1.05	15/16
1/2	1/2	TF3409x8	.687	.531	1.47	1.23	1-1/8
1/2	3/4	TF3409x8x12	.906	.531	1.59	1.23	1-3/8
3/4	1/2	TF3409x12x8	.687	.719	1.59	1.23	1-1/8
3/4	3/4	TF3409x12	.906	.719	1.59	1.36	1-3/8
1	1	TF3409x16	1.125	.938	1.97	1.62	1-5/8
1-1/4	1-1/4	TF3409x20	1.468	1.250	2.38	1.70	2
1-1/2	1-1/2	TF3409x24	1.734	1.500	2.64	2.08	2-3/8

STEEL

**90° Straight Thread O-Ring  
Male Elbow**

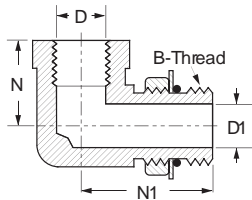
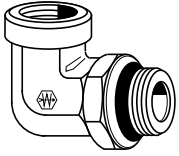

Replacement O-rings page 148.

Male Port Size	Fem. Pipe Thread	Catalog Number	Straight Thread B	D	D1	N	N1	Across Flats
1/2	3/8	<a href="#">C3459x8</a>	3/4-16	.562	.422	.63	1.47	7/8
5/8	1/2	<a href="#">C3459x10</a>	7/8-14	.687	.500	.75	1.81	1-1/16
3/4	3/4	<a href="#">C3459x12</a>	1-1/16-12	.906	.656	.81	2.00	1-5/16
1	1	<a href="#">C3459x16</a>	1-5/16-12	1.125	.876	1.00	2.25	1-5/8
1/4	1/8	<a href="#">TF3459x4</a>	7/16-20	.332	.172	.66	1.09	5/8
5/16	1/8	<a href="#">TF3459x5</a>	1/2-20	.332	.234	.66	1.13	5/8
3/8	1/4	<a href="#">TF3459x6</a>	9/16-18	.437	.297	.88	1.31	3/4
1/2	3/8	<a href="#">TF3459x8</a>	3/4-16	.562	.391	1.02	1.49	7/8
5/8	1/2	<a href="#">TF3459x10</a>	7/8-14	.687	.484	1.23	1.80	1-1/8
3/4	3/4	<a href="#">TF3459x12</a>	1-1/16-12	.906	.609	1.36	2.06	1-3/8
7/8	3/4	<a href="#">TF3459x14</a>	1-3/16-12	.906	.719	1.42	2.06	1-3/8
1	1	<a href="#">TF3459x16</a>	1-5/16-12	1.125	.844	1.62	2.17	1-5/8
1-1/4	1-1/4	<a href="#">TF3459x20</a>	1-5/8-12	1.468	1.078	1.70	2.38	2
1-1/2	1-1/2	<a href="#">TF3459x24</a>	1-7/8-12	1.703	1.312	2.08	2.58	2-3/8
2	2	<a href="#">TF3459x32</a>	2-1/2-12	2.180	1.781	2.39	3.02	2-7/8

**90° Straight Thread O-Ring  
Male Elbow Long**

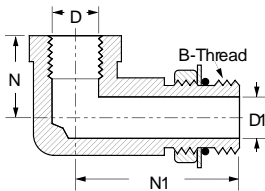
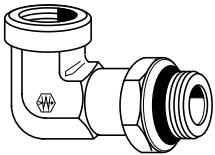

Replacement O-rings page 148.

Male Port Size	Fem. Pipe Thread	Catalog Number	Straight Thread B	D	D1	N	N1	Across Flats
1/2	3/8	<a href="#">C3469x8</a>	3/4-16	.562	.422	.63	2.94	7/8
5/8	1/2	<a href="#">C3469x10</a>	7/8-14	.687	.500	.75	3.56	1-1/16
3/4	3/4	<a href="#">C3469x12</a>	1-1/16-12	.906	.656	.81	4.13	1-5/16
1	1	<a href="#">C3469x16</a>	1-5/16-12	1.125	.876	1.00	4.63	1-5/8

**90° Straight Thread O-Ring  
Male Elbow to Male Pipe**

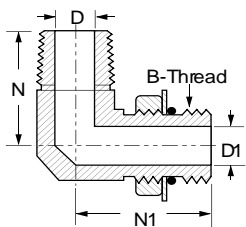
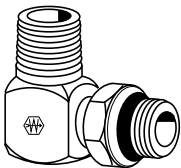

Replacement O-rings page 148.

Male Port Size	Male Pipe Thread	Catalog Number	Straight Thread B	D	D1	N	N1	Across Flats
1/4	1/8	<a href="#">TF3569x4</a>	7/16-20	.172	.188	.78	1.03	1/2
5/16	1/8	<a href="#">TF3569x5</a>	1/2-20	.234	.188	.78	1.09	9/16
3/8	1/4	<a href="#">TF3569x6</a>	9/16-18	.297	.281	1.09	1.25	5/8
1/2	3/8	<a href="#">TF3569x8</a>	3/4-16	.391	.406	1.22	1.45	13/16
5/8	1/2	<a href="#">TF3569x10</a>	7/8-14	.484	.531	1.47	1.70	15/16
3/4	3/4	<a href="#">TF3569x12</a>	1-1/16-12	.609	.719	1.59	1.94	1-1/8
7/8	3/4	<a href="#">TF3569x14</a>	1-3/16-12	.719	.719	1.69	2.00	1-1/4
1	1	<a href="#">TF3569x16</a>	1-5/16-12	.844	.938	1.97	2.05	1-3/8
1-1/4	1-1/4	<a href="#">TF3569x20</a>	1-5/8-12	1.078	1.250	2.38	2.25	1-3/4
1-1/2	1-1/2	<a href="#">TF3569x24</a>	1-7/8-12	1.312	1.500	2.64	2.39	2
2	2	<a href="#">TF3569x32</a>	2-1/2-12	1.781	1.938	3.00	2.89	2-5/8

## 90° Male Elbow Stainless Steel No. 3541x

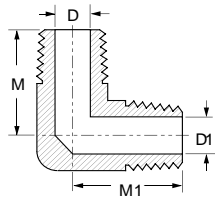
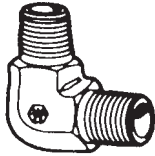

Male Pipe Thread	Male Pipe Thread	Catalog Number	D	D1	M	M1	Across Flats
1/8	1/8	C3529x2	.188	.188	.78	.78	7/16
1/4	1/4	C3529x4	.281	.281	1.09	1.09	9/16
3/8	3/8	C3529x6	.406	.406	1.22	1.22	3/4
1/2	1/2	C3529x8	.531	.531	1.47	1.47	7/8
3/4	3/4	C3529x12	.719	.719	1.59	1.59	1-1/16
1/8	1/8	TF3529x2	.188	.188	.78	.78	1/2
1/4	1/4	TF3529x4	.281	.281	1.09	1.09	5/8
3/8	1/4	TF3529x6x4	.406	.281	1.28	1.19	13/16
3/8	3/8	TF3529x6	.406	.406	1.21	1.21	13/16
1/2	3/8	TF3529x8x6	.531	.406	1.47	1.28	15/16
1/2	1/2	TF3529x8	.531	.531	1.47	1.47	15/16
3/4	1/2	TF3529x12x8	.719	.531	1.59	1.56	1-1/8
3/4	3/4	TF3529x12	.719	.719	1.59	1.59	1-1/8
1	3/4	TF3529x16x12	.938	.719	1.97	1.72	1-3/8
1	1	TF3529x16	.938	.938	1.97	1.97	1-3/8
1-1/4	1-1/4	TF3529x20	1.250	1.250	2.38	2.38	1-3/4
1-1/2	1-1/2	TF3529x24	1.938	1.938	2.64	2.64	2

## Tee Stainless Steel No. 3721x (Ref. SAE No. 140438)

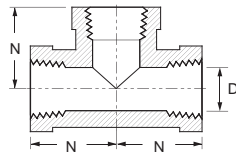
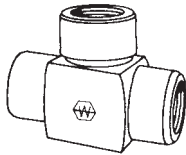
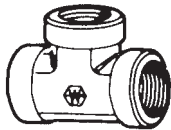

Fem. Pipe Thread	Catalog Number	D	N	Across Flats
1/8	C3709x2	.332	.66	9/16
1/4	C3709x4	.437	.88	3/4
3/8	C3709x6	.562	1.02	7/8
1/2	C3709x8	.687	1.23	1-1/16
3/4	C3709x12	.906	1.36	1-5/16
1	C3709x16	1.125	1.62	1-5/8
1-1/4	C3709x20	1.468	1.70	1-7/8
1/8	TF3709x2	.343	.66	5/8
1/4	TF3709x4	.437	.88	3/4
3/8	TF3709x6	.562	1.02	7/8
1/2	TF3709x8	.687	1.23	1-1/8
3/4	TF3709x12	.906	1.36	1-3/8
1	TF3709x16	1.275	1.62	1-5/8
1-1/4	TF3709x20	1.468	1.70	2
1-1/2	TF3709x24	1.710	2.08	2-3/8
2	TF3709x32	2.180	2.39	2-7/8

## Male Branch Tee Stainless Steel No. 3621x (Ref. SAE No. 140425)

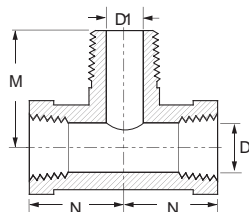
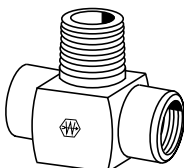
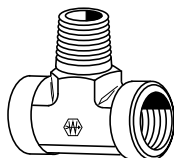

Male Pipe Thread	Fem. Pipe Thread	Catalog Number	D	D1	M	N	Across Flats
1/8	1/8	C3609x2	.332	.188	.78	.66	9/16
1/4	1/4	C3609x4	.437	.281	1.09	.88	3/4
1	1	C3609x16	1.125	.938	1.97	1.62	1-5/8
1/8	1/8	TF3609x2	.343	.188	.78	.66	5/8
1/4	1/4	TF3609x4	.437	.281	1.09	.87	3/4
3/8	3/8	TF3609x6	.562	.406	1.22	1.02	7/8
1/2	1/2	TF3609x8	.687	.531	1.47	1.23	1-1/8
3/4	3/4	TF3609x12	.906	.719	1.59	1.36	1-3/8
1	1	TF3609x16	1.125	.938	1.97	1.62	1-5/8
1-1/4	1-1/4	TF3609x20	1.468	1.250	2.38	1.70	2
1-1/2	1-1/2	TF3609x24	1.700	1.500	2.64	2.08	2-3/8

STEEL

## Male Run Tee

Stainless Steel No. 3771x  
(Ref. SAE No. 140424)

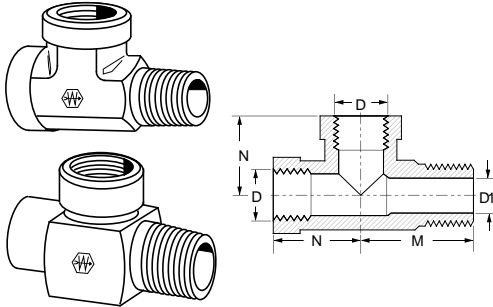

Fem. Pipe Thread	Male Pipe Thread	Catalog Number	D	D1	M	N	Across Flats
1/8	1/8	C3759x2	.332	.188	.78	.66	9/16
1/4	1/4	C3759x4	.437	.281	1.09	.88	3/4
3/8	3/8	C3759x6	.562	.406	1.22	1.02	7/8
1/2	1/2	C3759x8	.687	.531	1.47	1.23	1-1/16
3/4	3/4	C3759x12	.906	.719	1.59	1.36	1-5/16
1	1	C3759x16	1.125	.938	1.97	1.62	1-5/8
1/8	1/8	TF3759x2	.343	.188	.78	.66	5/8
1/4	1/4	TF3759x4	.437	.281	1.09	.88	3/4
3/8	3/8	TF3759x6	.562	.406	1.22	1.02	7/8
1/2	1/2	TF3759x8	.687	.531	1.47	1.23	1-1/8
3/4	3/4	TF3759x12	.906	.719	1.59	1.36	1-3/8
1	1	TF3759x16	1.125	.938	1.97	1.62	1-5/8
1-1/4	1-1/4	TF3759x20	1.468	1.250	2.38	1.70	2
1-1/2	1-1/2	TF3759x24	1.710	1.500	2.64	2.08	2-3/8
2	2	TF3759x32	2.180	1.938	3.00	2.39	2-7/8

## Female Run Tee

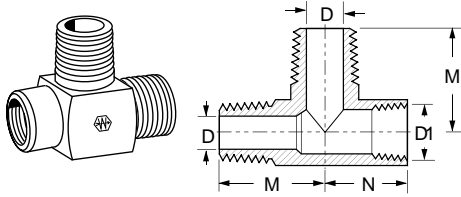

Fem. Pipe Thread	Male Pipe Thread	Catalog Number	D	D1	M	N	Across Flats
1/8	1/8	TF3805x2	.188	.343	.78	.66	5/8
1/4	1/4	TF3805x4	.281	.437	1.09	.88	3/4
3/8	3/8	TF3805x6	.406	.562	1.22	1.02	7/8
1/2	1/2	TF3805x8	.531	.687	1.47	1.23	1-1/8
3/4	3/4	TF3805x12	.719	.906	1.59	1.36	1-3/8
1	1	TF3805x16	.938	1.125	1.97	1.62	1-5/8
1-1/4	1-1/4	TF3805x20	1.250	1.468	2.38	1.70	2
1-1/2	1-1/2	TF3805x24	1.490	2.180	2.64	2.08	2-3/8

## Cross

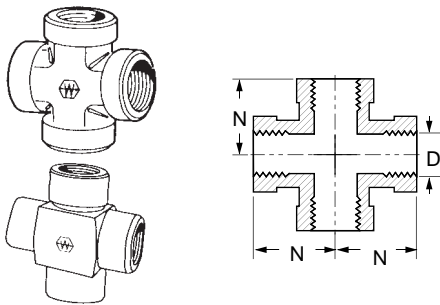

Fem. Pipe Thread	Catalog Number	D	N	Across Flats
3/8	C3959x6	.562	1.02	7/8
1/2	C3959x8	.687	1.23	1-1/16
3/4	C3959x12	.906	1.36	1-5/16
1/8	TF3959x2	.343	.66	5/8
1/4	TF3959x4	.437	.88	3/4
3/8	TF3959x6	.562	1.02	7/8
1/2	TF3959x8	.687	1.23	1-1/8
3/4	TF3959x12	.906	1.36	1-3/8
1	TF3959x16	1.125	1.62	1-5/8
1-1/4	TF3959x20	1.468	1.70	2
1-1/2	TF3959x24	1.710	2.08	2-3/8
2	TF3959x32	2.180	2.39	2-7/8

## Straight Thread O-Ring

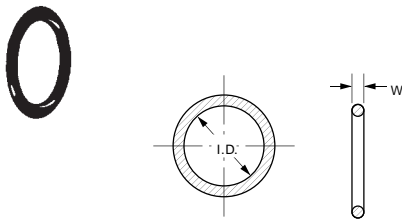

**Material:** Buna-N, 90 Durometer  
**Temperature Range:** -40°F to +250°F  
 (-40°C to +121°C)  
 Standard O-ring complies with SAE specification SAE J515 Type CH.

Tube O.D.	Catalog Number	W	I.D.
1/16	7629x1	.058	.185
1/8	7629x2	.064	.239
3/16	7629x3	.06	.301
1/4	7629x4	.07	.351
5/16	7629x5	.072	.414
3/8	7629x6	.078	.468
7/16	7629x7	.082	.530
1/2	7629x8	.087	.644
5/8	7629x10	.097	.755
3/4	7629x12	.116	.924
7/8	7629x14	.116	1.048
1	7629x16	.116	1.171
1-1/4	7629x20	.118	1.475
1-1/2	7629x24	.118	1.720
2	7629x32	.118	2.337

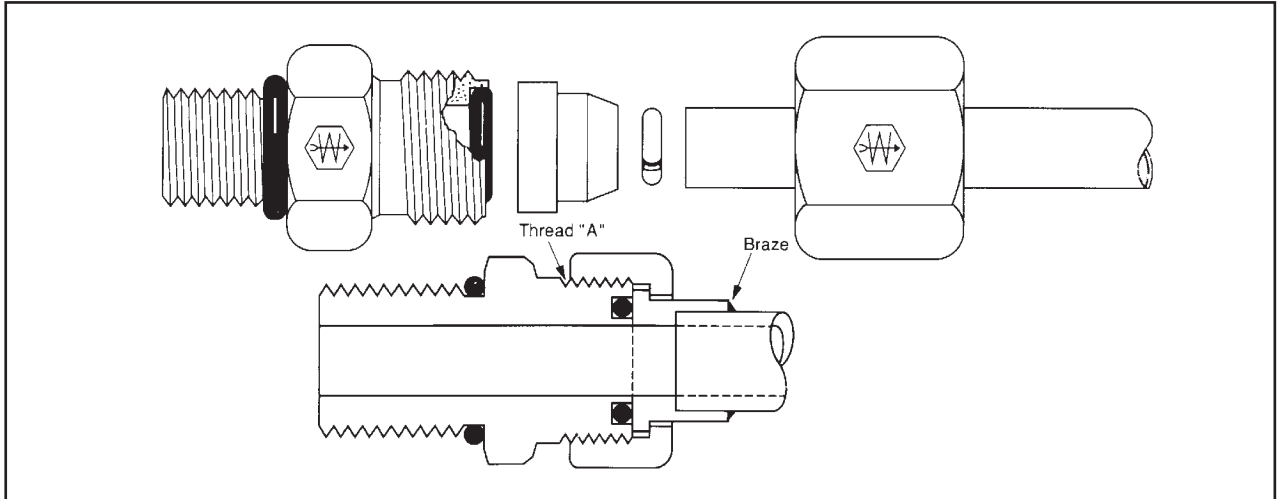

Tube O.D.	1/4	3/8	1/2	5/8	3/4	1	1-1/4	1-1/2
<b>For-Seal Thread</b>	9/16-18	11/16-16	13/16-16	1-14	1-3/16-12	1-7/16-12	1-11/16-12	2-12
<b>Maximum PSI</b>	6000	6000	6000	6000	6000	6000	4000	4000
<b>Adjustable Fittings PSI</b>	6000	6000	6000	6000	6000	5000	4000	3000

Rated pressures are for low surge, static type applications.

- **Typical Application**  
High pressure hydraulic, pneumatic and chemical processing.
- **Pressure\***  
Operating pressure to 6000 psi (1-1/4" and 1-1/2" maximum 4,000 psi). See thread chart.
- **Sealing Method**  
Face O-Ring.
- **Vibration**  
Excellent resistance.
- **Material**  
12L14 Steel.
- **Plating**  
All fittings are zinc plated, except braze parts which are oil dipped.
- **Used With**  
Steel and stainless steel tubing (tubing for brazing must be non-coated).
- **Advantages**  
Tubing is brazed for permanent leakproof connection.
- **Conformance**  
Meets SAE J1453.
- **How to Order**  
Individually by catalog number. O-Ring supplied with fittings.
- **NOTE**  
Refer to current price list for availability of cataloged items. Quotations and delivery of non-stock items supplied on request. Configuration and dimensions subject to change without notice. Additional information can be found in SAE J1453.
- **Assembly Instruction**  
See pages 150 & 151. See page 230 & 231 for assembly equipment.
- **Label Set:** **FS-2400** (adhesive)

\* Pressure ratings shown are the pressure ratings for the fitting and are not necessarily the pressure rating applicable in an assembly with hydraulic hose. The applicable pressure rating for an assembly with hydraulic hose is the lower value specified for the hose and the fitting. **149**

**Torque Requirements**

<b>Tube O.D.</b>	1/4	3/8	1/2	5/8	3/4	1	1-1/4	1-1/2
<b>Torque Ft-Lb. For-Seal SW. Nut</b>	10-12	18-20	32-35	46-50	65-70	92 100	125 140	150 165
<b>Torque Ft-Lb O-Ring Boss Straight Thread O-Ring Locknut Torque</b>	14-16	24-26	50-60	72-80	125 135	200 220	210 280	270 360

**Tube Preparation And Cleaning**

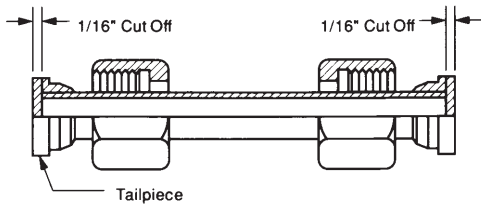

**NOTE:** Subtract 1/16" from tube length for each connection.

**Figure 1**



1. Establish the length of tubing required allowing 1/16" cut-off factor for each connection. (See Fig. 1)

2. Cut the tubing to proper length keeping ends reasonably square. A fine tooth hack saw or cut-off saw works well for this job. The use of a tubing cutter is not recommended due to possible collapse of the tube end, retarding the capillary action required for proper braze flow.



3. Clean the end of the tube with an alkaline cleaner to remove all traces of oil or grease. Deburr the end of the tube with a file and polish the outside of the tube down to bare metal with clean emery paper. Oil and grease residue must be removed first to avoid working the oily residue into the tube surface.



4. After polishing, wipe off any metal particles using a clean solvent if necessary. Avoid touching the tube end after final cleaning as this may leave greasy spots which will braze poorly.

Clean the tailpiece with an alkaline cleaner.



### Fluxing and Brazing Cleanup

Flux may be cleaned up using hot water and wire brush, using care not to scratch the tailpiece sealing surface.



1. Assemble proper size braze ring into counterbore of tailpiece. The correct size brazing will be slightly smaller than the inside diameter of the counterbore.



2. Clamp the tube securely in a vise, slide nut on tube, with threads pointing outward. Coat the tube end with flux and several inches of the tube outside diameter.



3. Coat the tailpiece liberally with flux including the counterbore and braze ring.



4. In a well ventilated area, apply heat uniformly to the tailpiece and the tube end. Watch the flux. The flux becomes completely clear when it is close to the proper brazing temperature. When ring melts, the tailpiece will settle down onto the end.

**NOTE:** General working knowledge of Acetylene torch brazing techniques is recommended.



5. Remove tube assembly from vise and check braze joint.



6. The braze alloy will flow down through the joint and should form a continuous fillet at the tube to tailpiece joint.

**NOTE:** Do not overheat. Excessive heat will only cause scaling and charred flux and make the parts more difficult to clean up.

**Tailpiece Silver Braze**  
(Ref. SAE No. 520115)

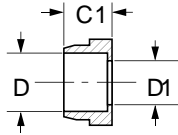
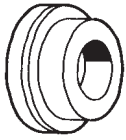

Oil Dipped

Tube O.D.	Catalog Number	D	D1	C1
1/4	4165x4	.256	.172	.374
3/8	4165x6	.381	.264	.374
1/2	4165x8	.506	.378	.374
5/8	4165x10	.631	.484	.413
3/4	4165x12	.757	.609	.551
1	4165x16	1.007	.811	.610
1-1/4	4165x20	1.257	1.024	.610
1-1/2	4165x24	1.507	1.260	.610

**For-Seal® Cadmium Free Braze Ring**

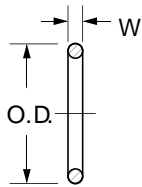

Tube O.D.	Catalog Number	Wire Dia.	O.D.
1/4	4640x4	.046	.250
3/8	4640x6	.046	.375
1/2	4640x8	.046	.500
5/8	4640x10	.046	.625
3/4	4640x12	.062	.750
1	4640x16	.062	1.000
1-1/4	4640x20	.062	1.250
1-1/2	4640x24	.062	1.500

**Bulkhead Nut**  
(Ref. SAE No. 520118)

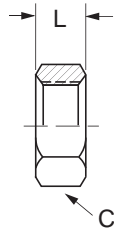

Tube O.D. A	Catalog Number	Hex C	L
1/4	4924x4	13/16	.27
3/8	4924x6	1	.31
1/2	4924x8	1-1/8	.35
5/8	4924x10	1-5/16	.41
3/4	4924x12	1-1/2	.41
1	4924x16	1-3/4	.41
1-1/4	4924x20	2	.41
1-1/2	4924x24	2-3/8	.41

**Nut**  
(Ref. SAE No. 520110)

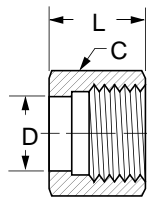
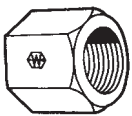

Tube O.D.	Catalog Number	Hex C	D	L
1/4	4105x4	11/16	.412	.58
3/8	4105x6	13/16	.531	.67
1/2	4105x8	15/16	.652	.83
5/8	4105x10	1-1/8	.829	.93
3/4	4105x12	1-3/8	.950	1.02
1	4105x16	1-5/8	1.144	1.10
1-1/4	4105x20	1-7/8	1.415	1.10
1-1/2	4105x24	2-1/4	1.727	1.10

**Cap**  
(Ref. SAE No. 520112)

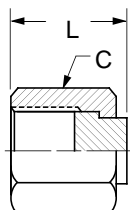
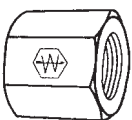

Tube O.D.	Catalog Number	Hex C	L
1/4	4129x4	11/16	.67
3/8	4129x6	13/16	.75
1/2	4129x8	15/16	.90
5/8	4129x10	1-1/8	1.00
3/4	4129x12	1-3/8	1.10
1	4129x16	1-5/8	1.17
1-1/4	4129x20	1-7/8	1.17
1-1/2	4129x24	2-1/4	1.17

### Plug (Ref. SAE No. 520109)

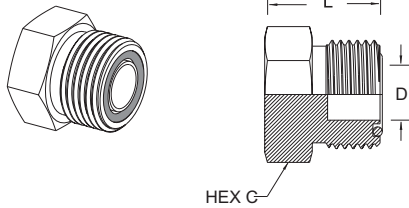

Tube O.D.	Catalog Number	Hex C	D	L
1/4	4229x4	5/8	.172	.659
3/8	4229x6	3/4	.264	.751
1/2	4229x8	7/8	.378	.854
5/8	4229x10	1-1/16	.484	1.020
3/4	4229x12	1-1/4	.609	1.080
1	4229x16	1-1/2	.811	1.100
1-1/4	4229x20	1-3/4	1.024	1.100
1-1/2	4229x24	2-1/8	1.260	1.100

### Union (Ref. SAE No. 520101)

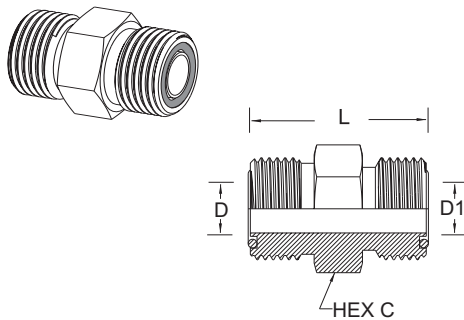

Tube O.D.	Tube O.D.	Catalog Number	Hex C	D	D1	L
1/4	1/4	4305x4	5/8	.172	.172	1.08
3/8	1/4	4305x6x4	3/4	.264	.172	1.17
3/8	3/8	4305x6	3/4	.264	.264	1.22
1/2	3/8	4305x8x6	7/8	.378	.264	1.33
1/2	1/2	4305x8	7/8	.378	.378	1.39
5/8	1/2	4305x10x8	1-1/16	.484	.378	1.57
5/8	5/8	4305x10	1-1/16	.484	.484	1.68
3/4	1/2	4305x12x8	1-1/4	.609	.378	1.69
3/4	5/8	4305x12x10	1-1/4	.609	.484	1.80
3/4	3/4	4305x12	1-1/4	.609	.609	1.86
1	3/4	4305x16x12	1-1/2	.812	.609	1.92
1	1	4305x16	1-1/2	.811	.811	1.94
1-1/4	1-1/4	4305x20	1-3/4	1.024	1.024	2.02
1-1/2	1-1/2	4305x24	2-1/8	1.260	1.260	2.09

### Bulkhead Union (Ref. SAE No. 520601)

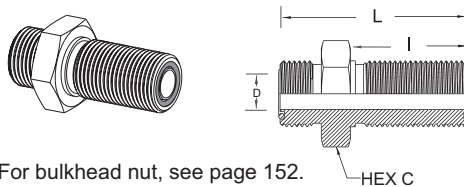

For bulkhead nut, see page 152.

Male Tube O.D.	Catalog Number	Hex C	D	I	L
3/8	4325x6	1	.264	1.34	2.09
1/2	4325x8	1-1/8	.378	1.44	2.30
3/4	4325x12	1-1/2	.609	1.64	2.72
1	4325x16	1-3/4	.812	1.66	2.76
1-1/4	4325x20	2	1.024	1.66	2.76
1-1/2	4325x24	2-3/8	1.260	1.66	2.76

### Straight Thread O-Ring Connector (Ref. SAE No. 520120)

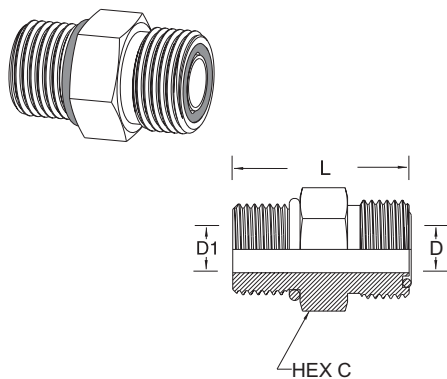

For replacement Straight Thread O-ring, see page 148.

Male Tube O.D.	Male Port Size	Catalog Number	Hex C	D	D1	L
1/4	1/4	4315x4	5/8	.172	.172	1.133
1/4	3/8	4315x4x6	11/16	.172	.172	1.202
3/8	5/8	4315x6x10	1-1/16	.264	.484	1.530
3/8	1/4	4315x6x4	3/4	.264	.172	1.343
3/8	3/8	4315x6	3/4	.264	.264	1.252
3/8	1/2	4315x6x8	7/8	.378	.264	1.378
1/2	3/8	4315x8x6	7/8	.378	.264	1.472
1/2	1/2	4315x8	7/8	.378	.378	1.441
1/2	5/8	4315x8x10	1	.378	.484	1.590
1/2	3/4	4315x8x12	1-1/4	.378	.609	1.748
5/8	5/8	4315x10	1-1/16	.484	.484	1.700
3/4	3/4	4315x12	1-1/4	.609	.609	1.918
3/4	1	4315x12x16	1-1/2	.609	.609	1.960
1	3/4	4315x16x12	1-1/2	.812	.609	2.138
1	1	4315x16	1-1/2	.811	.811	1.978
1	1-1/4	4315x16x20	1-7/8	.812	1.709	2.058
1-1/4	1	4315x20x16	1-3/4	1.024	.843	2.278
1-1/4	1-1/4	4315x20	1-7/8	1.024	1.024	2.058
1-1/2	1-1/2	4315x24	2-1/8	1.260	1.260	2.125

**Straight Thread O-Ring  
Extended**  
(Ref. SAE No. 520122)

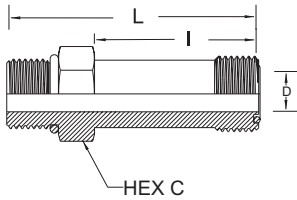
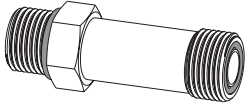

For replacement Straight Thread O-ring, see page 148.

Male Tube O.D.	Male Port Size	Catalog Number	Hex C	D	I	L
3/8	3/8	4316x6	3/4	.264	1.46	2.27
1/2	1/2	4316x8	7/8	.378	1.75	2.67
3/4	3/4	4316x12	1-1/4	.609	2.52	3.76
1	1	4316x16	1-1/2	.811	2.87	4.14
1-1/4	1-1/4	4316x20	1-7/8	1.024	3.41	4.76
1-1/2	1-1/2	4316x24	2-1/8	1.260	3.82	5.26

**Male 37° to Female For-Seal®**

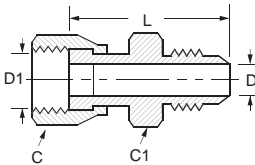
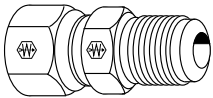

Female Tube O.D.	Male Tube Size	Catalog Number	Hex C	Hex C1	D	L
1/4	1/4	4213x4	11/16	5/8	.172	1.50
3/8	3/8	4213x6	13/16	3/4	.297	1.62
1/2	1/2	4213x8	15/16	7/8	.392	1.90
5/8	5/8	4213x10	1-1/8	1-1/16	.484	2.25
3/4	3/4	4213x12	1-3/8	1-1/4	.609	2.48
1	1	4213x16	1-5/8	1-1/2	.811	2.84

**Male For-Seal® Male Pipe  
Adapter**

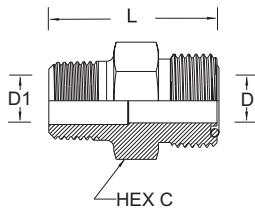
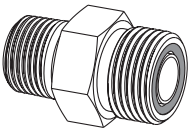

Tube O.D.	Male Pipe Size	Catalog Number	Hex C	D	D1	L
3/8	3/8	4205x6x6	3/4	.264	.406	1.30
1/2	3/8	4205x8	7/8	.378	.406	1.45
1/2	1/2	4205x8x8	7/8	.378	.484	1.64
5/8	1/2	4205x10	1-1/16	.484	.531	1.82
3/4	1/2	4205x12x8	1-1/4	.406	.484	1.87
3/4	3/4	4205x12	1-1/4	.609	.719	1.94
3/4	1	4205x12x16	1-3/8	.609	.938	1.87
1	1	4205x16	1-1/2	.811	.938	2.19
1-1/4	1-1/4	4205x20	1-3/4	1.024	1.250	2.30

### 45° Male Elbow

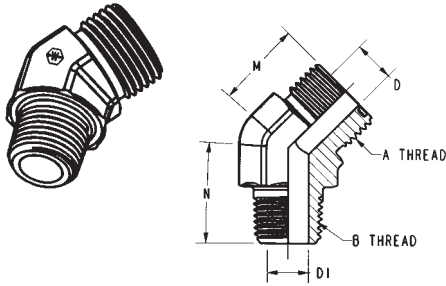

Male Tube O.D.	Male Pipe Thread	Catalog Number	D	D1	M	N	Across Flats
1/4	1/8	4355x4	.172	.188	.63	.64	9/16
3/8	1/4	4355x6	.264	.281	.74	.86	3/4
1/2	3/8	4355x8	.378	.406	.80	.95	7/8
5/8	1/2	4355x10	.484	.531	.92	1.17	1-1/16
3/4	3/4	4355x12	.609	.719	1.02	1.20	1-5/16
1	1	4355x16	.812	.939	1.18	1.48	1-5/8
1-1/4	1-1/4	4355x20	1.026	1.252	1.26	1.67	1-5/8
1-1/2	1-1/2	4355x24	1.262	1.502	1.45	1.77	1-7/8

### Straight Thread O-Ring Connector 45° Elbow (Ref. SAE No. 520320)

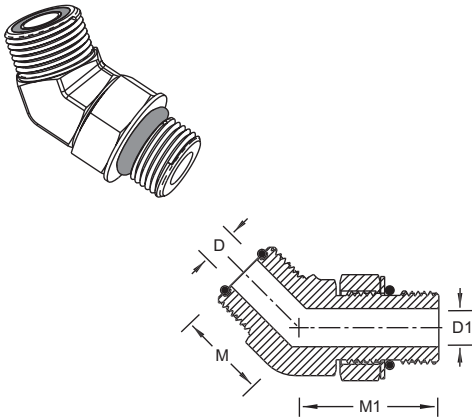

For replacement straight thread O-ring, see page 148.

Male Tube O.D.	Male Port Size	Catalog Number	D	D1	M	M1	Across Flats
1/4	1/4	4365x4	.172	.172	.63	1.18	9/16
1/4	3/8	4365x4x6	.172	.264	.68	1.30	3/4
3/8	1/4	4365x6x4	.264	.172	.74	1.22	3/4
3/8	3/8	4365x6	.264	.264	.74	1.30	3/4
3/8	1/2	4365x6x8	.264	.390	.74	1.43	3/4
1/2	3/8	4365x8x6	.378	.264	.80	1.27	3/4
1/2	1/2	4365x8	.378	.390	.80	1.43	3/4
1/2	5/8	4365x8x10	.378	.484	.82	1.76	1-1/16
1/2	3/4	4365x8x12	.378	.609	.87	1.97	1-3/16
5/8	1/2	4365x10x8	.484	.390	.92	1.59	1-1/16
5/8	5/8	4365x10	.484	.484	.92	1.76	1-1/16
5/8	3/4	4365x10x12	.484	.609	.94	1.97	1-3/16
3/4	5/8	4365x12x10	.609	.484	1.02	1.81	1-3/16
3/4	3/4	4365x12	.609	.609	1.02	1.97	1-5/16
3/4	1	4365x12x16	.609	.811	1.16	2.06	1-5/16
1	3/4	4365x16x12	.811	.609	1.12	2.03	1-7/16
1	1	4365x16	.812	.811	1.18	2.06	1-1/2
1	1-1/4	4365x16x20	.811	1.081	1.26	2.11	1-5/8
1-1/4	1-1/4	4365x20	1.024	1.081	1.26	2.11	1-5/8
1-1/2	1-1/2	4365x24	1.260	1.312	1.45	2.11	1-7/8

### 45° Bulkhead Elbow (Ref. SAE No. 520201)

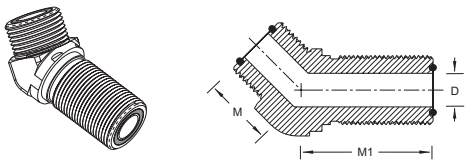

For Bulkhead Nut, see page 152.

Male Tube O.D.	Catalog Number	D	M	M1	Across Flats
1/4	4375x4	.172	.63	1.73	9/16
3/8	4375x6	.264	.74	1.91	3/4
1/2	4375x8	.378	.80	2.01	3/4
5/8	4375x10	.484	.92	2.23	1-1/16
3/4	4375x12	.609	1.02	2.39	1-3/16
1	4375x16	.811	1.18	2.57	1-7/16
1-1/4	4375x20	1.045	1.26	2.64	1-11/16
1-1/2	4375x24	1.312	1.45	2.64	1-7/8

### Union 90° Elbow (Ref. SAE No. 520201)

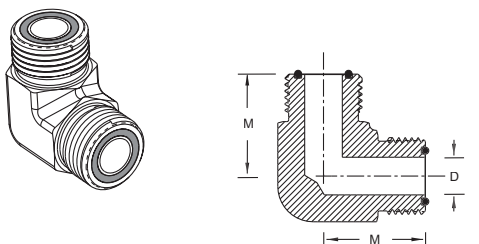

Male Tube O.D.	Catalog Number	D	M	Across Flats
1/4	4505x4	.172	.85	9/16
3/8	4505x6	.264	.98	3/4
1/2	4505x8	.378	1.10	3/4
5/8	4505x10	.484	1.31	1-1/16
3/4	4505x12	.609	1.47	1-3/16
1	4505x16	.811	1.64	1-7/16
1-1/4	4505x20	1.045	1.76	1-5/8
1-1/2	4505x24	1.312	1.92	1-7/8
2	4505x32	-	-	-

STEEL

**Bulkhead Union 90° Elbow**  
(Ref. SAE No. 520701)

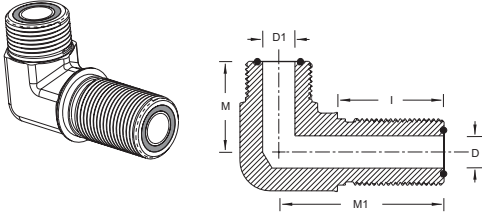

For bulkhead nut, see page 152.

Male Tube O.D.	Port Size	Catalog Number	D	D1	M	M1	I	Across Flats
1/4	1/4	4525x4	.172	.172	.89	1.85	1.24	9/16
3/8	3/8	4525x6	.264	.264	1.02	2.05	1.34	3/4
1/2	1/2	4525x8	.378	.378	1.14	2.18	1.44	7/8
5/8	5/8	4525x10	.484	.484	1.36	1.36	1.44	1-1/16
3/4	3/4	4525x12	.609	.609	1.52	2.64	1.60	1-5/16
1	1	4525x16	.811	.811	1.67	2.80	1.64	1-5/8
1-1/4	1-1/4	4525x20	1.024	1.024	1.79	2.97	1.66	1-7/8
1-1/2	1-1/2	4525x24	1.260	1.260	1.95	3.13	1.66	1-7/8

**90° Male Elbow**

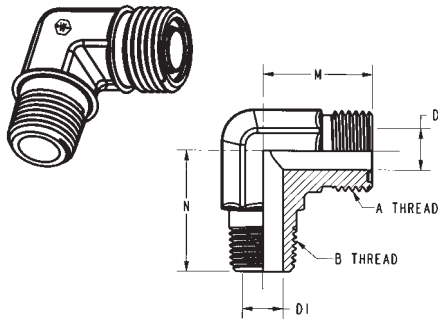

Male Tube O.D.	Port Size	Catalog Number	D	D1	M	N	Across Flats
1/4	1/8	4405x4	.172	.188	.85	.78	9/16
3/8	1/4	4405x6	.264	.281	.80	1.09	3/4
1/2	3/8	4405x8	.378	.406	1.10	1.22	3/4
5/8	1/2	4405x10	.484	.531	1.31	1.47	1-1/16
3/4	3/4	4405x12	.609	.719	1.47	1.59	1-5/16
1	1	4405x16	.812	.939	1.64	1.97	1-5/8
1-1/4	1-1/4	4405x20	1.026	1.252	1.76	2.38	1-5/8
1-1/2	1-1/2	4405x24	1.262	1.502	1.92	2.64	1-7/8

**Straight Thread O-Ring 90° Elbow**  
(Ref. SAE No. 520220)

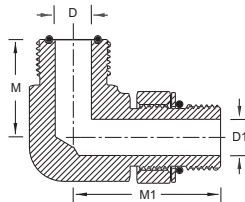
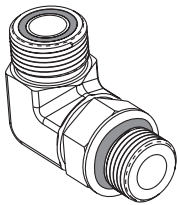

Male Tube O.D.	Port Size	Catalog Number	D	D1	M	M1	Across Flats
1/4	1/4	4515x4	.172	.172	.85	1.29	9/16
1/4	5/16	4515x4x5	.172	.234	.85	1.29	9/16
1/4	3/8	4515x4x6	.172	.264	.92	1.45	3/4
1/4	1/2	4515x4x8	.172	.390	.97	1.60	3/4
3/8	5/8	4515x6x10	.264	.484	1.15	1.97	3/4
3/8	3/4	4515x6x12	.264	.609	1.25	2.17	1-3/16
3/8	1/4	4515x6x4	.264	.172	.98	1.37	3/4
3/8	5/16	4515x6x5	.264	.234	.98	1.37	3/4
3/8	3/8	4515x6	.264	.264	.98	1.45	3/4
3/8	1/2	4515x6x8	.264	.390	1.04	1.60	3/4
1/2	5/8	4515x8x10	.378	.484	1.21	1.97	1-1/16
1/2	3/4	4515x8x12	.378	.484	1.32	2.17	1-1/16
1/2	3/8	4515x8x6	.378	.264	1.10	1.44	3/4
1/2	1/2	4515x8	.378	.390	1.10	1.60	3/4
5/8	5/8	4515x10	.484	.484	1.31	1.97	1-1/16
5/8	3/4	4515x10x12	.484	.609	1.41	2.17	1-3/16
5/8	1/2	4515x10x8	.484	.390	1.31	1.80	1-1/16
3/4	5/8	4515x12x10	.609	.484	1.47	2.01	1-5/16
3/4	3/4	4515x12	.609	.609	1.47	2.17	1-5/16
3/4	1	4515x12x16	.609	.811	1.62	2.35	1-5/16
3/4	1/2	4515x12x8	.609	.390	1.47	1.84	1-3/16
1	3/4	4515x16x12	.811	.609	1.64	2.32	1-5/8
1	7/8	4515x16x14	.811	.609	1.64	2.32	1-5/8
1	1	4515x16	.811	.811	1.64	2.35	1-5/8
1	1-1/4	4515x16x20	.811	1.081	1.76	2.45	1-5/8
1-1/4	1	4515x20x16	1.024	.811	1.76	2.42	1-5/8
1-1/4	1-1/4	4515x20	1.024	1.081	1.76	2.45	1-7/8
1-1/4	1-1/2	4515x20x24	1.024	1.312	1.92	2.59	1-7/8
1-1/2	1-1/4	4515x24x20	1.312	1.081	1.92	2.59	1-7/8
1-1/2	1-1/2	4515x24	1.312	1.312	1.92	2.59	1-7/8

For replacement straight thread O-ring, see page 148.

### 90° Elbow Straight Thread Swivel - Long

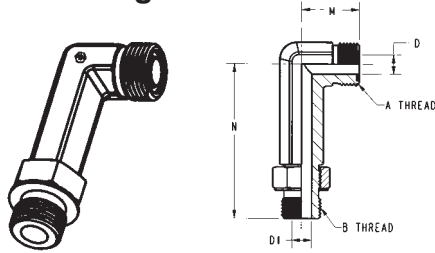

Male Tube O.D.	Male Port Size	Catalog Number	D	D1	M	N	Across Flats
1/4	1/4	4515x4L	.172	.180	.85	2.23	9/16
3/8	3/8	4515x6L	.264	.300	.98	2.61	3/4
1/2	1/2	4515x8L	.378	.398	1.10	2.95	3/4
5/8	5/8	4515x10L	.484	.498	1.31	3.51	1-1/16
3/4	3/4	4515x12L	.609	.616	1.47	3.97	1-3/16
1	1	4515x16L	.812	.852	1.64	4.51	1-7/16
1-1/4	1-1/4	4515x20L	1.026	1.090	1.76	4.98	1-5/8
1-1/2	1-1/2	4515x24L	1.262	1.326	1.92	5.48	1-7/8

### 90° Straight Thread Swivel (Ref. SAE No. 520281)

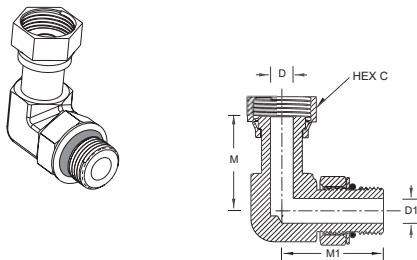

Female Tube O.D.	Port Size	Catalog Number	D	D1	M	M1	Hex C	Across Flats
1/4	1/4	4535x4	.165	.180	1.04	1.29	11/16	9/16
3/8	3/8	4535x6	.264	.300	1.15	1.45	13/16	3/4
1/2	1/2	4535x8	.258	.398	1.49	1.60	15/16	7/8
5/8	5/8	4535x10	.453	.498	1.62	1.97	1-1/8	1-1/16
3/4	3/4	4535x12	.547	.616	1.82	2.17	1-3/8	1-3/8
1	1	4535x16	.783	.852	2.10	2.35	1-5/8	1-5/8
1-1/4	1-1/4	4535x20	1.026	1.090	2.29	2.45	1-7/8	1-5/8
1-1/2	1-1/2	4535x24	1.262	1.326	2.41	2.59	2-1/4	1-7/8

### Union Tee (Ref. SAE No. 520401)

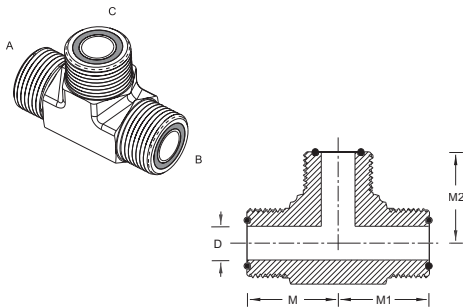

Male Tube O.D. A	Male Tube O.D. B	Male Tube O.D. C	Catalog Number	D	D1	M	M1	M2	Across Flats
1/4	1/4	1/4	4705x4	.172	.172	.85	.85	.85	9/16
3/8	3/8	3/8	4705x6	.264	.264	.98	.98	.98	3/4
3/8	3/8	1/2	4705x6x6x8	.264	.378	1.04	1.04	1.10	3/4
1/2	3/8	1/2	4705x8x6x8	.264	.378	.98	.98	1.10	3/4
1/2	1/2	1/2	4705x8	.378	.378	1.10	1.10	1.10	3/4
5/8	5/8	5/8	4705x10	.484	.484	1.31	1.31	1.31	1-1/16
3/4	3/4	3/4	4705x12	.609	.609	1.47	1.47	1.47	1-3/16
1	1	1	4705x16	.811	.811	1.64	1.64	1.64	1-5/8
1-1/4	1-1/4	1-1/4	4705x20	1.024	1.024	1.76	1.76	1.76	1-5/8
1-1/2	1-1/2	1-1/2	4705x24	1.260	1.260	1.92	1.92	1.92	1-7/8

### Straight Thread Branch Tee (Ref. SAE No. 520429)

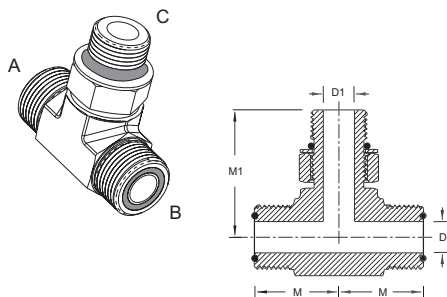

Tube O.D.	Port Size	Catalog Number	D	D1	M	M1	Across Flats
1/4	1/4	4715x4	.172	.172	.85	1.29	9/16
3/8	3/8	4715x6	.264	.264	.98	1.45	3/4
3/8	1/2	4715x6x8	.264	.391	1.04	1.60	7/8
1/2	3/8	4715x8x6	.378	.264	1.10	1.44	3/4
1/2	1/2	4715x8	.378	.390	1.10	1.60	3/4
5/8	5/8	4715x10	.484	.484	1.31	1.97	1-1/16
3/4	3/4	4715x12	.609	.609	1.47	2.17	1-3/16
3/4	1	4715x12x16	.609	.812	1.62	2.35	1-5/8
1	1	4715x16	.811	.845	1.64	2.35	1-5/8
1-1/4	1	4715x20x16	1.046	.845	1.76	2.45	1-15/16
1-1/4	1-1/4	4715x20	1.046	1.081	1.76	2.45	1-7/8
1-1/2	1-1/2	4715x24	1.260	1.313	1.92	2.59	1-7/8

\*Brazed construction.  
For replacement straight thread O-ring, see page 148.

**Straight Thread Run Tee**  
(Ref. SAE No. 520428)

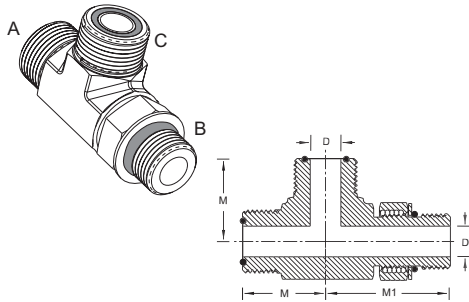

For replacement straight thread O-ring, see page 148.

Tube O.D. A	Port Size B	Tube O.D. C	Catalog Number	D	D1	M	M1	Across Flats
1/4	1/4	1/4	4716x4	.172	.172	.85	1.29	9/16
1/4	1/4	3/8	4716x4x6	.172	.264	1.39	1.45	3/4
3/8	3/8	3/8	4716x6	.264	.264	.98	1.45	3/4
1/2	1/2	1/2	4716x8	.378	.391	1.10	1.60	7/8
5/8	5/8	5/8	4716x10	.484	.484	1.31	1.97	1-1/16
3/4	3/4	3/4	4716x12	.609	.609	1.47	2.17	1-3/16
3/4	3/4	1	4716x12x16	.609	.812	1.62	2.32	1-7/16
3/4	1	3/4	4716x12x16x12	.609	.812	1.62	2.35	1-7/16
1	1	3/4	4716x16x12	.812	.609	1.64	2.35	1-7/16
1	1	1	4716x16	.812	.845	1.64	2.35	1-7/16
1-1/4	1-1/4	1-1/4	4716x20	1.046	1.081	1.76	2.45	1-7/8
1-1/2	1-1/2	1-1/2	4716x24	1.313	1.313	1.92	2.59	1-7/8

**Bulkhead Run Tee**  
(Ref. SAE No. 520958)

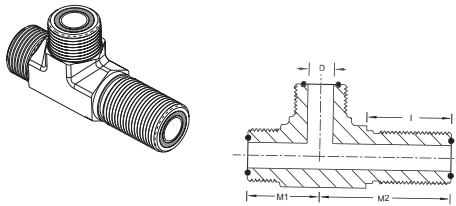

For Bulkhead Nut, see page 152.

Tube O.D.	Catalog Number	D	I	M	M1	M2	Across Flats
1/4	4726x4	.172	1.24	.89	.89	1.85	9/16
3/8	4726x6	.264	1.34	1.02	1.02	2.05	3/4
1/2	4726x8	.378	1.44	1.14	1.14	2.18	3/4
5/8	4726x10	.484	1.60	1.36	1.36	2.48	1-1/16
3/4	4726x12	.609	1.64	1.52	1.52	2.65	1-3/16
1	4726x16	.812	1.66	1.67	1.67	2.80	1-7/16
1-1/4	4726x20	1.024	1.66	1.79	1.79	2.97	1-5/8
1-1/2	4726x24	1.260	1.66	1.95	1.95	3.13	1-7/8

**Male For-Seal® Cross**

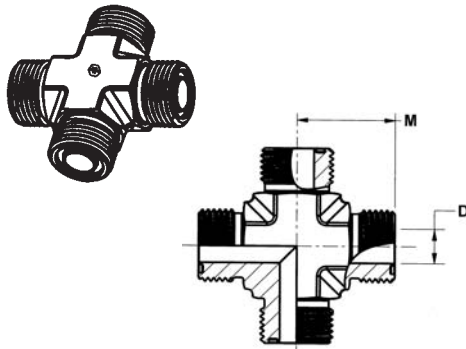

Tube O.D.	Catalog Number	D	M	Across Flats
1/4	4955x4	.172	.89	9/16
3/8	4955x6	.264	1.02	3/4
1/2	4955x8	.378	1.14	7/8
5/8	4955x10	.484	1.36	1-1/16
3/4	4955x12	.609	1.52	1-5/16
1	4955x16	.812	1.67	1-5/8
1-1/4	4955x20	1.026	1.79	1-5/8
1-1/2	4955x24	1.262	1.95	1-7/8

**O-Ring, For-Seal®**

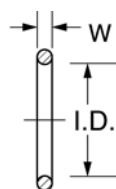

**Material:** Buna N, 90 Durometer  
**Temperature:** -40°F to +250°F (-40°C to +121°C)  
 Standard o-ring complies with SAE specification SAE J515 Type CH

Tube O.D.	Catalog Number	W	I.D.
1/4	4629x4	.070 ± .005	.301 ± .005
3/8	4629x6	.070 ± .005	.364 ± .005
1/2	4629x8	.070 ± .005	.489 ± .005
5/8	4629x10	.070 ± .005	.614 ± .005
3/4	4629x12	.070 ± .005	.739 ± .005
1	4629x16	.070 ± .006	.926 ± .006
1-1/4	4629x20	.070 ± .006	1.176 ± .006
1-1/2	4629x24	.070 ± .010	1.489 ± .010



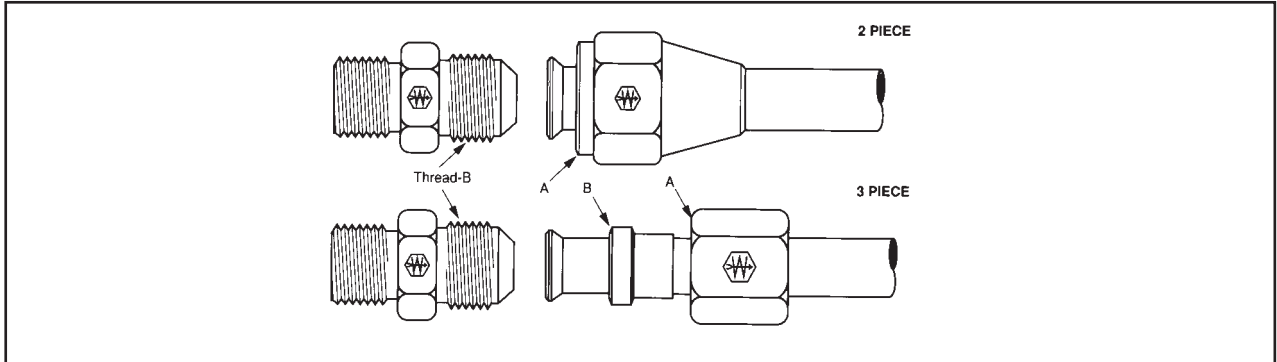

Tube O.D.	1/8	3/16	1/4	5/16	3/8	1/2	5/8	3/4	7/8	1	1-1/4	1-1/2	2
Thread Size-B	5/16-24	3/8-24	7/16-20	1/2-20	9/16-18	3/4-16	7/8-14	1-1/16-12	1-3/16-12	1-5/16-12	1-5/8-12	1-7/8-12	2-1/2-12

### Forged Fittings and Adapters

#### 5000 Series Pressure Rating Chart

Connection Type	End Size												
	1/8"	3/16"	1/4"	5/16"	3/8"	1/2"	5/8"	3/4"	7/8"	1"	1-1/4"	1-1/2"	2"
SAE Fittings	6000	5000	5000	5000	5000	4000	4000	4000	4000	4000	3000	3000	3000
W/Adjustable Straight Thread O-Ring	5000	5000	4500	4000	4000	4000	3000	3000	2500	2500	2000	1500	1125
With Male Pipe	6000		5000		5000	4000		4000		4000	3000	2500	2500
With Female Pipe	5000		5000		4000	3000		2500		2000	1500	1500	1000

### Brazed Fittings (TF)/SAE

#### 5000 Series Pressure Rating Chart

Connection Type	End Size												
	1/8"	3/16"	1/4"	5/16"	3/8"	1/2"	5/8"	3/4"	7/8"	1"	1-1/4"	1-1/2"	2"
SAE Fittings	5000	5000	5000	5000	5000	4500	3500	3500	3000	3000	2500	2000	1500
W/Adjustable Straight Thread O-Ring	5000	5000	4500	4000	4000	4000	3000	3000	2500	2500	2000	1500	1125
With Male or Female Pipe	5000	5000	5000	5000	4000	3000	3000	2500	2500	2000	1150	1000	1000

- Typical Application**  
 Hydraulic, instrumentation and chemical processing systems.
- Pressure**  
 Refer to the pressure charts above. The maximum working pressure of an adapter is the lower working pressure of the end size. Ex: C3069x8x6, 8 = 4000 psi and 6 = 5000 psi. Maximum working pressure is 4000 psi.
- Vibration**  
 Good resistance. Vibration resistance decreases with increase in tube size. Use two piece design when greater vibration resistance is required.
- Temperature Range**  
 -65°F to +400°F (-53°C to +204°C) at maximum operating pressures.
- Material**  
 Carbon Steel - AISI/SAE 12L14  
 Stainless Steel - Type 316  
 Plating - Zinc, yellow dichromate.
- Used With**  
 Copper, brass, steel, aluminum and other tubing that can be flared. See page 28-32 for material compatibility.
- Advantages**  
 Zinc Plate. Choice of two or three-piece design. Broad selection of styles and sizes. Interchangeable with all sources.

- Conformance**  
 Meets specifications and standards of ASA, ASME and SAE.
- How to Order**  
 To order a three-piece assembly, prefix the catalog number with a "3". Example: To order a male connector C5205x4 with nut and sleeve assembled, order C35205x4. To order a two-piece assembly, order nut and body separately. Example: Order male connector C5205x4 and two-piece style nut C5115x4. Bodies, nuts and sleeves can be ordered separately by catalog number. Stainless steel bodies, nuts and sleeves are ordered separately by catalog number.  
  
 To order Weathercote finish (black phosphate coating) use "W" prefix in place of "C". Example: W5205x4 (special order only).  
  
 To order with pipe sealants (Seal-A-Thread), add a "Z" suffix to the catalog number. Example: C5205x4Z (special order only).
- NOTE**  
 Refer to current price list for availability of cataloged items. Quotations and delivery of non-stock items supplied on request. Configurations and dimensions subject to change without notice. Additional information can be found in SAE J514.

- NOTE (Continued)**  
 Weatherhead fittings with a "C" prefix are made from a forged construction. Example: C3509x2. Weatherhead fittings with a "TF" prefix are made from a brazed construction. Example: TF3509x2.
- Assembly Instructions**
  - Cut tubing to desired length. Make sure all burrs are removed and ends are cut square.
  - Slide nut on tube. Threaded end of nut "A" must face toward fitting body. (See above.)
  - Slide sleeve on tube (3-piece assembly only). Collar end "B" of sleeve must face toward fitting body. (See above.)
  - Flare end of tubing with 37° flaring tool.
    - Check flare diameter. For dimensional data on 37° flares, see page 26.
    - Examine flare for excessive thin-out.
    - On thin wall, welded or brazed tubing, use double flare to prevent pinch-off and cracked flares.
  - Lubricate threads and assemble to fitting body. Nut should be turned hand tight.
  - Tighten assembly until finger tight, then until a sharp torque rise is encountered. From that point, apply one-sixth turn with a wrench.

Label Set: **FS-200** (adhesive)

### Dimensional Data

**Dimensional Data Two-Piece Assemblies**

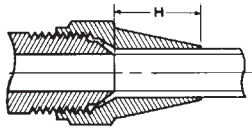

**Dimensional Data Three-Piece Assemblies**

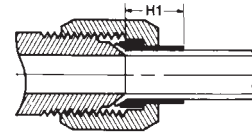

**NOTE:** H & H1 are dimensions of fittings assembled to hand tight condition.

Tube O.D.	H	H1
-----------	---	----

1/8	—	.31
3/16	—	.38
1/4	.59	.36
5/16	.66	.41
3/8	.69	.47
1/2	.81	.50
5/8	.94	.64
3/4	—	.61
7/8	—	.69
1	—	.75
1-1/4	—	.73
1-1/2	—	1.05
2	—	1.08

### Straight Thread O-Ring Thread Sizes

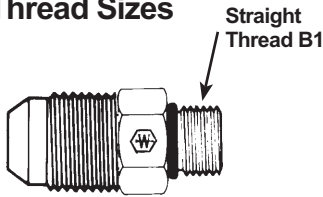

Port Size	Thread Size B1	Port Size	Thread Size B1
1/8	5/16-24	3/4	1-1/16-12
3/16	3/8-24	7/8	1-3/16-12
1/4	7/16-20	1	1-5/16-12
5/16	1/2-20	1-1/4	1-5/8-12
3/8	9/16-18	1-1/2	1-7/8-12
1/2	3/4-16	2	2-1/2-12
5/8	7/8-14		

### Straight Thread O-Ring Fitting

**Straight Thread O-Ring Fitting**

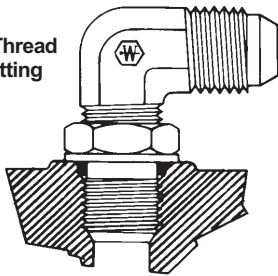

### Adjustable Fittings

- Permit exact positioning of tees and elbows.
  - Provide a leakproof joint.
  - Eliminate distorted bosses from over tightening.
1. Lubricate O-ring by coating with a light oil or petrolatum and push back-up washer and O-ring to the extreme rear of the O-ring groove.
  2. Turn the lock nut down until it just contacts the back-up washer.
  3. Screw fitting by hand into straight thread boss until the back-up washer contacts the face of the boss.
  4. Position the fitting by backing out (counter-clockwise) up to one full turn. Hold fitting in desired position and tighten lock nut with a wrench.
  5. Assemble tube to fitting. Retighten lock nut.
- NOTE:** O-ring, lock nuts and back-up washers are preassembled on all straight thread fittings.

### Swivel Fitting (Used with Connector)

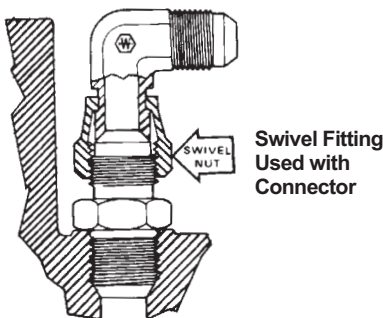

Weatherhead swivel end fittings can be used with a straight connector when space limitations will not permit full rotation of standard straight thread elbows and tees.

1. Screw connector into the O-ring boss and tighten.
2. Thread swivel nut onto connector.
3. Hold fitting in desired position and tighten swivel nut with a wrench.

# SAE 37° Flare-Twin®

**Steel Fittings**

## Sleeve 3 Piece Stainless Steel No. 5177x (Ref. SAE No. 070115)

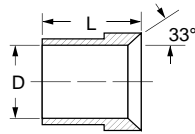
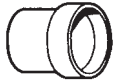

Tube O.D.	Catalog Number	D	L
1/8	C5165x2	.130	.34
3/16	C5165x3	.193	.34
1/4	C5165x4	.255	.41
5/16	C5165x5	.318	.44
3/8	C5165x6	.380	.50
1/2	C5165x8	.505	.56
5/8	C5165x10	.631	.66
3/4	C5165x12	.756	.68
7/8	C5165x14	.881	.76
1	C5165x16	1.006	.78
1-1/4	C5165x20	1.260	.91
1-1/2	C5165x24	1.510	1.12
2	C5165x32	2.014	1.19

## Sleeve 3 Piece Metric (Ref. SAE No. 070115)

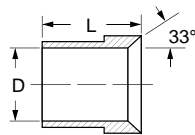

Adapts Standard SAE Flare-Twin® fittings for use with metric tubing.

Tube O.D. (Inch Size)	Tube O.D. (Metric Size)	Catalog Number	D	L
1/4	6MM	C5165x4x6MM	.241	.41
5/16	8MM	C5165x5x8MM	.320	.44
3/8	10MM	C5165x6x10MM	.399	.50
1/2	12MM	C5165x8x12MM	.478	.56
5/8	14MM	C5165x10x14MM	.556	.66
5/8	15MM	C5165x10x15MM	.596	.66
5/8	16MM	C5165x10x16MM	.636	.66
3/4	18MM	C5165x12x18MM	.717	.68
7/8	20MM	C5165x14x20MM	.793	.76
1	25MM	C5165x16x25MM	.990	.78
1-1/4	30MM	C5165x20x30MM	1.191	.91
1-1/4	32MM	C5165x20x32MM	1.270	.91
1-1/2	38MM	C5165x24x38MM	1.510	1.12

## Nut 3 Piece Stainless Steel No. 5117x (Ref. SAE No. 070110)

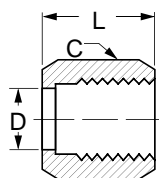
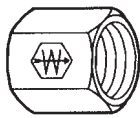

SAE style 'B'

Tube O.D.	Catalog Number	Hex C	D	L
1/8	C5105x2	3/8	.181	.55
3/16	C5105x3	7/16	.243	.61
1/4	C5105x4	9/16	.306	.62
5/16	C5105x5	5/8	.375	.68
3/8	C5105x6	11/16	.441	.73
1/2	C5105x8	7/8	.571	.85
5/8	C5105x10	1	.698	.98
3/4	C5105x12	1-1/4	.835	1.03
7/8	C5105x14	1-3/8	.961	1.09
1	C5105x16	1-1/2	1.089	1.13
1-1/4	C5105x20	2	1.347	1.23
1-1/2	C5105x24	2-1/4	1.617	1.42
2	C5105x32	2-7/8	2.167	1.75

## 2 Piece Nut (Short)

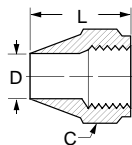
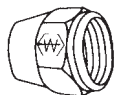

Tube O.D.	Catalog Number	Hex C	D	L
1/4	C5125x4	9/16	.255	.59
5/16	C5125x5	5/8	.318	.59
3/8	C5125x6	11/16	.380	.66
1/2	C5125x8	7/8	.505	.81
5/8	C5125x10	1	.631	.94
3/4	C5125x12	1-1/4	.756	1.14

## 2 Piece Nut (Ref. SAE No. 070111)

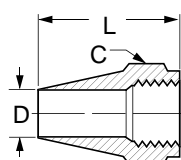
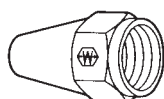

SAE style 'B'

Tube O.D.	Catalog Number	Hex C	D	L
1/4	C5115x4	9/16	.255	1.00
5/16	C5115x5	5/8	.318	1.06
3/8	C5115x6	11/16	.380	1.09
1/2	C5115x8	7/8	.505	1.28
5/8	C5115x10	1	.631	1.48
3/4	C5115x12	1-1/4	.756	1.66
7/8	C5115x14	1-3/8	.881	1.81
1	C5115x16	1-1/2	1.006	1.94
1-1/4	C5115x20	2	1.260	2.19
1-1/2	C5115x24	2-1/4	1.510	2.31

STEEL

**Bulkhead Nut**  
Stainless Steel No. 7936x  
(Ref. SAE No. 070118)

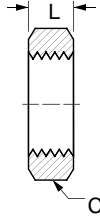

Tube O.D.	Catalog Number	Hex C	L
1/8	C5924x2	9/16	.22
3/16	C5924x3	5/8	.22
1/4	C5924x4	11/16	.25
5/16	C5924x5	3/4	.28
3/8	C5924x6	13/16	.27
1/2	C5924x8	1	.31
5/8	C5924x10	1-1/8	.36
3/4	C5924x12	1-3/8	.41
7/8	C5924x14	1-1/2	.41
1	C5924x16	1-5/8	.41
1-1/4	C5924x20	1-7/8	.41
1-1/2	C5924x24	2-1/8	.41
2	C5924x32	2-3/4	.41

**Cap**  
Stainless Steel No. 5141x  
(Ref. SAE No. 070112)

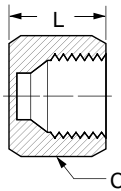
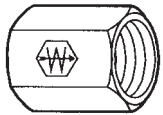

Tube O.D.	Catalog Number	Hex C	L
1/8	C5129x2	3/8	.50
3/16	C5129x3	7/16	.56
1/4	C5129x4	9/16	.59
5/16	C5129x5	5/8	.61
3/8	C5129x6	11/16	.62
1/2	C5129x8	7/8	.75
5/8	C5129x10	1	.84
3/4	C5129x12	1-1/4	.91
1	C5129x16	1-1/2	1.02
1-1/4	C5129x20	2	1.06
1-1/2	C5129x24	2-1/4	1.19
2	C5129x32	2-7/8	1.44

**Plug**  
Stainless Steel No. 5241x  
(Ref. SAE No. 070109)

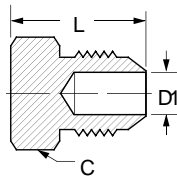
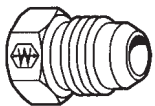

Tube O.D.	Catalog Number	Hex C	L	D1 Opt.
1/4	C5229x4	1/2	.80	.172
5/16	C5229x5	9/16	.80	.234
3/8	C5229x6	5/8	.84	.297
1/2	C5229x8	13/16	.94	.391
5/8	C5229x10	15/16	1.10	.484
3/4	C5229x12	1-1/8	1.28	.609
7/8	C5229x14	1-1/4	1.31	.719
1	C5229x16	1-3/8	1.33	.844
1-1/4	C5229x20	1-11/16	1.45	1.078
1-1/2	C5229x24	2	1.65	1.312
2	C5229x32	2-5/8	2.05	1.781

**Reducer**  
Stainless Steel No. 5027x  
(Ref. SAE No. 070123)  
Example assembly No. C35015x

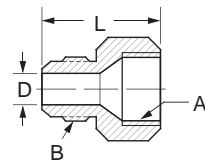
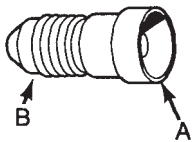

\*One Piece Design

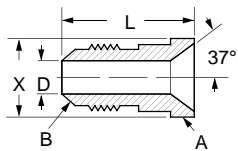

Two Piece Design

Female Reduction A	Male Reduction B	Catalog Number	D	L	Dia. X	Hex C
3/8	1/4	C5015x6x4	.172	.97	.502	-
1/2	1/4	C5015x8x4	.172	1.00	.682	-
1/2	3/8	C5015x8x6	.297	1.00	.682	-
5/8*	1/4	C5015x10x4	.172	1.47	-	1
5/8*	3/8	C5015x10x6	.297	1.41	-	1
5/8*	1/2	C5015x10x8	.391	1.41	-	1
3/4	1/4	C5015x12x4	.172	1.09	.972	-
3/4	3/8	C5015x12x6	.297	1.09	.972	-
3/4	1/2	C5015x12x8	.391	1.19	.972	-
3/4*	5/8	C5015x12x10	.484	1.58	-	1-1/4
7/8*	3/8	C5015x14x6	.297	1.59	-	1-3/8
7/8*	1/2	C5015x14x8	.391	1.69	-	1-3/8
7/8*	5/8	C5015x14x10	.484	1.73	-	1-3/8
7/8*	3/4	C5015x14x12	.609	1.80	-	1-3/8
1*	1/2	C5015x16x8	.391	1.72	-	1-1/2
1*	5/8	C5015x16x10	.484	1.79	-	1-1/2
1*	3/4	C5015x16x12	.609	1.47	1.222	-
1*	7/8	C5015x16x14	.719	1.87	-	1-1/2
1-1/4	3/4	C5015x20x12	.609	1.50	1.534	-
1-1/4*	1	C5015x20x16	.844	2.00	-	2
1-1/2*	1-1/4	C5015x24x20	1.078	2.15	-	2-1/4
2*	1-1/2	C5015x32x24	1.312	2.61	-	2-7/8

NOTE: Order 3-piece nut C5105x to use reducer.  
No sleeve necessary.

# SAE 37° Flare-Twin®

Steel  
Fittings

## Small Hex Union

Stainless Steel No. **5317x**

(Ref. SAE No. 070101)

Example assembly No. C35305x2

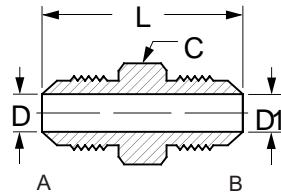
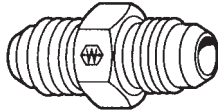

Tube O.D. A	Tube O.D. B	Catalog Number	Hex C	D	D1	L
1/8	1/8	C5305x2	7/16	.062	.062	1.17
3/16	3/16	C5305x3	7/16	.125	.125	1.23
1/4	1/4	C5305x4	1/2	.172	.172	1.37
5/16	1/4	C5305x5x4	9/16	.234	.172	1.37
5/16	5/16	C5305x5	9/16	.234	.234	1.37
3/8	1/4	C5305x6x4	5/8	.297	.172	1.40
3/8	5/16	C5305x6x5	5/8	.297	.234	1.40
3/8	3/8	C5305x6	5/8	.297	.297	1.41
1/2	3/8	C5305x8x6	13/16	.391	.297	1.52
1/2	1/2	C5305x8	13/16	.391	.391	1.62
5/8	1/2	C5305x10x8	15/16	.484	.391	1.78
5/8	5/8	C5305x10	15/16	.484	.484	1.88
3/4	1/2	C5305x12x8	1-1/8	.609	.391	1.95
3/4	5/8	C5305x12x10	1-1/8	.609	.484	2.05
3/4	3/4	C5305x12	1-1/8	.609	.609	2.16
7/8	7/8	C5305x14	1-1/4	.719	.719	2.21
1	3/4	C5305x16x12	1-3/8	.844	.609	2.20
1	1	C5305x16	1-3/8	.844	.844	2.25
1-1/4	1-1/4	C5305x20	1-11/16	1.078	1.078	2.43
1-1/2	1-1/2	C5305x24	2	1.312	1.312	2.75
2	2	C5305x32	2-5/8	1.781	1.781	3.40

## Large Hex Union

Stainless Steel No. **5318x**

(Ref. SAE No. 070119)

Example assembly No. C35306x4

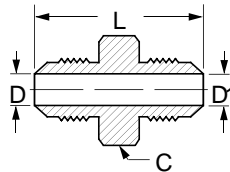
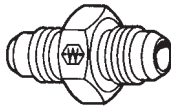

Tube O.D.	Catalog Number	Hex C	D	D1	L
1/4	C5306x4	11/16	.172	.172	1.37
5/16	C5306x5	3/4	.234	.234	1.37
3/8	C5306x6	13/16	.297	.297	1.41
1/2	C5306x8	1	.391	.391	1.62
5/8	C5306x10	1-1/8	.484	.484	1.88
3/4	C5306x12	1-3/8	.609	.609	2.16
1	C5306x16	1-5/8	.844	.844	2.25
1-1/4	C5306x20	1-7/8	1.078	1.078	2.43
1-1/2	C5306x24	2-1/8	1.312	1.312	2.75

## Bulkhead Union

Stainless Steel No. **5337x**

(Ref. SAE No. 070601)

Example assembly No. C35325x4

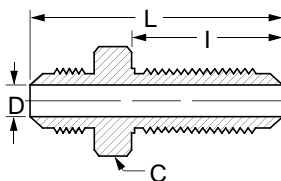
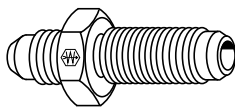

Tube O.D.	Catalog Number	Hex C	D	I	L
3/16	C5325x3	5/8	.125	1.14	1.90
1/4	C5325x4	11/16	.172	1.23	2.07
5/16	C5325x5	3/4	.234	1.23	2.07
3/8	C5325x6	13/16	.297	1.31	2.18
1/2	C5325x8	1	.391	1.47	2.44
5/8	C5325x10	1-1/8	.484	1.61	2.74
3/4	C5325x12	1-3/8	.609	1.78	3.09
1	C5325x16	1-5/8	.844	1.78	3.14
1-1/4	C5325x20	1-7/8	1.078	1.83	3.31

For Bulkhead nut see page 162. Included with assembly.

STEEL

**Male Connector**

Stainless Steel No. **5217x**

(Ref. SAE No. 070102)

Example assembly No. **C35205x4**

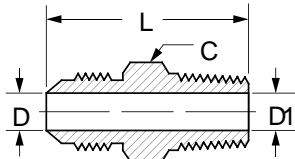
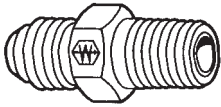

\*Optional counterbore for D1.

Tube O.D.	Male Pipe Thread	Catalog Number	Hex C	D	D1 Opt.	L
1/8	1/8	C5205x2	7/16	.062	.188*	1.11
3/16	1/8	C5205x3	7/16	.125	.188*	1.14
1/4	1/8	C5205x4	1/2	.172	.188*	1.22
1/4	1/4	C5205x4x4	9/16	.172	.281*	1.42
1/4	3/8	C5205x4x6	3/4	.172	.406*	1.42
1/4	1/2	C5205x4x8	7/8	.172	.531*	1.68
5/16	1/8	C5205x5	9/16	.234	.188	1.22
5/16	1/4	C5205x5x4	5/8	.234	.281*	1.42
5/16	3/8	C5205x5x6	13/16	.234	.406*	1.42
3/8	1/8	C5205x6x2	5/8	.297	.188	1.24
3/8	1/4	C5205x6	5/8	.297	.281	1.43
3/8	3/8	C5205x6x6	3/4	.297	.297*	1.43
3/8	1/2	C5205x6x8	7/8	.297	.531*	1.69
1/2	1/4	C5205x8x4	13/16	.391	.281	1.53
1/2	3/8	C5205x8	13/16	.391	.406*	1.53
1/2	1/2	C5205x8x8	15/16	.391	.531*	1.79
1/2	3/4	C5205x8x12	1-1/8	.391	.719*	1.85
5/8	3/8	C5205x10x6	15/16	.484	.406	1.70
5/8	1/2	C5205x10	15/16	.484	.531*	1.89
5/8	3/4	C5205x10x12	1-1/8	.484	.484*	1.95
3/4	1/2	C5205x12x8	1-1/8	.609	.531	2.06
3/4	3/4	C5205x12	1-1/8	.609	.719*	2.06
3/4	1	C5205x12x16	1-3/8	.609	.938*	2.25
7/8	3/4	C5205x14	1-1/4	.718	.718*	2.09
1	3/4	C5205x16x12	1-3/8	.844	.719	2.25
1	1	C5205x16	1-3/8	.844	.938*	2.30
1	1-1/4	C5205x16x20	1-11/16	.844	1.250*	2.40
1-1/4	1	C5205x20x16	1-11/16	1.078	.938	2.42
1-1/4	1-1/4	C5205x20	1-11/16	1.078	1.250*	2.45
1-1/2	1-1/4	C5205x24x20	2	1.312	1.250*	2.65
1-1/2	1-1/2	C5205x24	2	1.312	1.500*	2.68
2	2	C5205x32	2-5/8	1.781	1.938*	3.11

**Female Connector**

Stainless Steel No. **5267x**

(Ref. SAE No. 070103)

Example assembly No. **C35255x4**

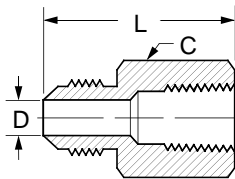
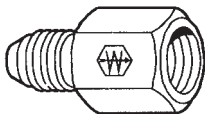

Tube O.D.	Fem. Pipe Thread	Catalog Number	Hex C	D	L
1/8	1/8	C5255x2	9/16	.062	1.12
3/16	1/8	C5255x3	9/16	.125	1.13
1/4	1/8	C5255x4	9/16	.172	1.19
1/4	1/4	C5255x4x4	3/4	.172	1.39
5/16	1/8	C5255x5	9/16	.234	1.17
5/16	1/4	C5255x5x4	3/4	.234	1.39
3/8	1/4	C5255x6	3/4	.297	1.40
3/8	3/8	C5255x6x6	7/8	.297	1.46
1/2	3/8	C5255x8	7/8	.391	1.56
1/2	1/2	C5255x8x8	1-1/8	.391	1.79
5/8	3/8	C5255x10x6	7/8	.484	1.89
5/8	1/2	C5255x10	1-1/8	.484	1.89
3/4	1/2	C5255x12x8	1-1/8	.609	2.05
3/4	3/4	C5255x12	1-3/8	.609	2.06
1	1	C5255x16	1-5/8	.844	2.35
1-1/4	1-1/4	C5255x20	2	1.078	2.49
1-1/2	1-1/2	C5255x24	2-3/8	1.312	2.62
2	2	C5255x32	2-7/8	1.781	2.97

**Female Bulkhead Connector**

Example assembly No. **C35275x4**

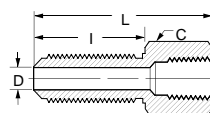
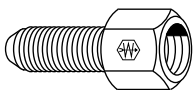

For Bulkhead nut see page 162. Included with assembly.

Tube O.D.	Fem. Pipe Thread	Catalog Number	Hex C	D	I	L
1/4	1/8	C5275x4	11/16	.172	1.23	1.84
3/8	1/4	C5275x6	13/16	.297	1.31	2.06
1/2	3/8	C5275x8	1	.391	1.47	2.35
5/8	1/2	C5275x10	1-1/8	.484	1.61	2.66
3/4	3/4	C5275x12	1-3/8	.609	1.78	2.91
1	1	C5275x16	1-5/8	.844	1.78	3.09

# SAE 37° Flare-Twin®

**Steel  
Fittings**

## Male 37° SAE to Female For-Seal®

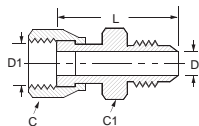

Tube O.D.	37° Tube Size	Catalog Number	Hex C1	Hex C	D	D1	L
1/4	1/4	4213x4	11/16	5/8	.172	.165	1.50
3/8	3/8	4213x6	13/16	3/4	.297	.264	1.62
1/2	1/2	4213x8	15/16	7/8	.397	.358	1.90
5/8	5/8	4213x10	1-1/8	1-1/16	.484	.453	2.25
3/4	3/4	4213x12	1-3/16	1-1/4	.609	.547	2.48
1	1	4213x16	1-5/8	1-1/2	.811	.783	2.84

## Straight Thread O-Ring Connector

Stainless Steel No. 5327x

(Ref. SAE No. 070120)

Example assembly No. C35315x4

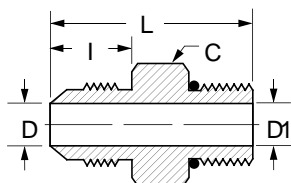
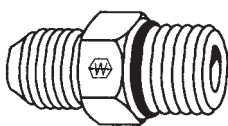

Tube O.D.	Port Size	Catalog Number	Hex C	D	D1 Opt.	I	L
1/8	1/8	C5315x2	7/16	.062	.062*	.45	1.06
3/16	3/16	C5315x3	1/2	.125	.125*	.48	1.10
1/4	1/4	C5315x4	9/16	.172	.172*	.55	1.23
1/4	5/16	C5315x4x5	5/8	.172	.234*	.55	1.23
1/4	3/8	C5315x4x6	11/16	.172	.297*	.55	1.29
1/4	1/2	C5315x4x8	7/8	.172	.391*	.55	1.37
5/16	1/4	C5315x5x4	5/8	.234	.172	.55	1.23
5/16	5/16	C5315x5	5/8	.234	.234*	.55	1.23
5/16	3/8	C5315x5x6	11/16	.234	.297*	.55	1.29
3/8	1/4	C5315x6x4	11/16	.297	.172	.56	1.27
3/8	5/16	C5315x6x5	11/16	.297	.234	.56	1.27
3/8	3/8	C5315x6	11/16	.297	.297*	.56	1.30
3/8	1/2	C5315x6x8	7/8	.297	.391*	.56	1.38
3/8	5/8	C5315x6x10	1	.297	.484*	.56	1.50
1/2	3/8	C5315x8x6	13/16	.391	.297	.66	1.44
1/2	1/2	C5315x8	7/8	.391	.391*	.66	1.48
1/2	5/8	C5315x8x10	1	.391	.484*	.66	1.60
1/2	3/4	C5315x8x12	1-1/4	.391	.609*	.66	1.76
5/8	1/2	C5315x10x8	1	.484	.391	.76	1.64
5/8	5/8	C5315x10	1	.484	.484*	.76	1.70
5/8	3/4	C5315x10x12	1-1/4	.484	.609*	.76	1.86
5/8	1	C5315x10x16	1-1/2	.484	.844*	.76	1.89
3/4	1/2	C5315x12x8	1-1/4	.609	.391	.86	1.94
3/4	5/8	C5315x12x10	1-1/8	.609	.484	.86	1.88
3/4	3/4	C5315x12	1-1/4	.609	.609*	.86	1.97
3/4	7/8	C5315x12x14	1-3/8	.609	.718*	.86	1.96
3/4	1	C5315x12x16	1-1/2	.609	.844*	.86	1.99
3/4	1-1/4	C5315x12x20	1-7/8	.609	1.078*	.86	2.08
7/8	7/8	C5315x14	1-3/8	.719	.719*	.89	1.99
1	5/8	C5315x16x10	1-1/2	.844	.484	.91	2.07
1	3/4	C5315x16x12	1-1/2	.844	.609	.91	2.04
1	1	C5315x16	1-1/2	.844	.844*	.91	2.04
1	1-1/4	C5315x16x20	1-7/8	.844	1.078*	.91	2.12
1-1/4	1	C5315x20x16	1-7/8	1.078	.844	.96	2.33
1-1/4	1-1/4	C5315x20	1-7/8	1.078	1.078*	.96	2.17
1-1/4	1-1/2	C5315x20x24	2-1/8	1.078	1.312*	.96	2.24
1-1/2	1-1/4	C5315x24x20	2-1/8	1.312	1.078*	1.08	2.53
1-1/2	1-1/2	C5315x24	2-1/8	1.312	1.312*	1.08	2.37
1-1/2	2	C5315x24x32	2-3/4	1.312	1.781*	1.08	2.53
2	1-1/2	C5315x32x24	2-3/4	1.781	1.312*	1.33	2.81
2	2	C5315x32	2-3/4	1.781	1.781	1.33	2.78

\*Optional counterbore for D1.  
Replacement O-rings page 178.

## Straight Thread O-Ring Extended Connector

(Ref. SAE No. 070122)

Example assembly No. C35316x4

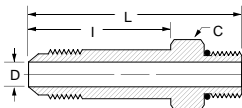

Tube O.D.	Stud Port Size	Catalog Number	Hex C	D	I	L
1/4	1/4	C5316x4	9/16	.172	1.39	2.08
3/8	3/8	C5316x6	11/16	.297	1.56	2.31
1/2	3/8	C5316x8x6	7/8	.297	1.56	2.38
1/2	1/2	C5316x8	7/8	.391	1.88	2.70
5/8	5/8	C5316x10	1	.484	2.09	3.04
3/4	3/4	C5316x12	1-1/4	.609	2.50	3.61
1	1	C5316x16	1-1/2	.844	2.84	3.98
1-1/4	1-1/4	C5316x20	1-7/8	1.078	3.47	4.69

Replacement O-rings page 178.

STEEL

## Adapter

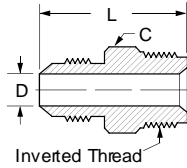
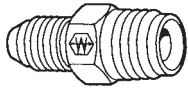

Tube O.D.	Inverted Thread	Catalog Number	Hex C	D	L
1/4	7/16-24	C5880x4	1/2	.172	1.08
5/16	1/2-20	C5880x5	9/16	.234	1.14
3/8	5/8-18	C5880x6	11/16	.297	1.22
1/2	3/4-18	C5880x8	13/16	.391	1.46

## Female 37° SAE Swivel to Male Pipe Adapter

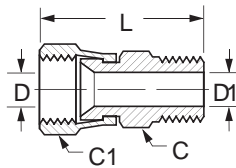
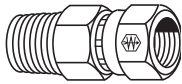

Tube O.D.	Male Pipe Size	Catalog Number	Hex C	Hex C1	D	D1	L
1/4	1/4	9100x4x4	9/16	9/16	.172	.281*	1.50
5/16	1/4	9100x5x4	11/16	5/8	.234	.281*	1.57
3/8	1/4	9100x6x4	11/16	11/16	.297	.281	1.69
3/8	3/8	9100x6x6	11/16	11/16	.297	.406*	1.69
1/2	3/8	9100x8x6	7/8	7/8	.391	.406*	1.87
1/2	1/2	9100x8x8	7/8	7/8	.391	.531*	2.05
5/8	3/8	9100x10x6	1	1	.484	.406	1.91
5/8	1/2	9100x10x8	1	1	.484	.531*	2.11
3/4	1/2	9100x12x8	1-1/8	1-1/4	.609	.531	2.21
3/4	3/4	9100x12x12	1-1/8	1-1/4	.609	.719*	2.21
1	3/4	9100x16x12	1-3/8	1-1/2	.844	.719	2.36
1	1	9100x16x16	1-3/8	1-1/2	.844	.938*	2.55
1-1/4	1-1/4	9100x20x20	1-7/8	2	1.078	1.250*	2.73

\*Optional counterbore for D1.

## Male 37° SAE to Male Metric Standpipe

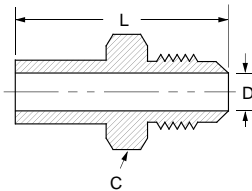
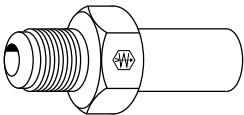

Tube O.D.	Tube O.D. (mm)	Catalog Number	Hex C	L	D
1/4	6MM	MC5019x4x6	9/16	1.58	.16
1/4	8MM	MC5019x4x8	9/16	1.68	.17
3/8	10MM	MC5019x6x10	3/4	1.67	.28
1/2	12MM	MC5019x8x12	7/8	1.97	.32
1/2	14MM	MC5019x8x14	7/8	1.89	.39
5/8	15MM	MC5019x10x15	1	2.03	.43
5/8	16MM	MC5019x10x16	1	2.07	.47
3/4	16MM	MC5019x12x16	1-1/4	2.22	.47
3/4	18MM	MC5019x12x18	1-1/4	2.12	.55
3/4	20MM	MC5019x12x20	1-1/4	2.38	.61
1	22MM	MC5019x16x22	1-1/2	2.21	.67
1	25MM	MC5019x16x25	1-1/2	2.54	.79

## 37° SAE Flare to O-Ring Port Adapter

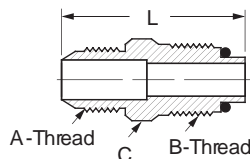
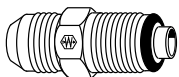

Tube Size	Port Size	Catalog Number	Replacement O-Ring	Thread A	Thread B	Hex C	L
1/4	1/4	41157x4	7629x1	7/16-20	7/16-24	7/16	1.33
3/8	3/8	41157x6	7629x3	9/16-18	5/8-18	5/8	1.47
1/2	1/2	41157x8	7629x5	3/4-16	3/4-16	3/4	1.91
5/8	5/8	41157x10	7629x7	7/8-14	7/8-14	15/16	2.23
3/4	3/4	41157x12	7629x8	1-1/16-12	1-1/16-16	1-1/8	2.13



# SAE 37° Flare-Twin®

**Steel  
Fittings**

## 37° SAE Female Swivel to Male O-Ring

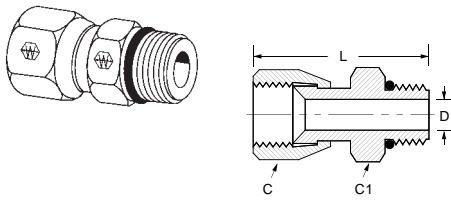

For replacement Straight Thread O-rings, see page 178.

Tube O.D.	Port Size	Catalog Number	Hex C	Hex C1	L	D
1/4	1/4	C5216x4x4	9/16	9/16	.95	1.47
1/4	3/8	C5216x4x6	11/16	11/16	1.00	1.35
3/8	3/8	C5216x6x6	11/16	11/16	1.11	1.48
3/8	1/2	C5216x6x8	11/16	7/8	1.17	1.52
1/2	3/8	C5216x8x6	7/8	3/4	1.71	1.62
1/2	1/2	C5216x8x8	7/8	7/8	1.31	1.60
5/8	5/8	C5216x10x10	1	1	1.45	1.97
3/4	3/4	C5216x12x12	1-1/4	1-1/4	1.61	2.16
1	1	C5216x16x16	1-1/2	1-1/2	1.69	2.28
1-1/4	1-1/4	C5216x20x20	2	1-7/8	1.82	2.42
1-1/2	1-1/2	C5216x24x24	2-1/8	2-1/8	2.61	2.61
2	2	C5216x32x32	2-3/4	2-3/4	2.94	2.94

## Female 37° SAE Swivel to Female Pipe



Tube O.D.	Female Pipe	Catalog Number	Hex C	Hex C1	L	D
1/4	1/4	C5256x4x4	9/16	3/4	1.32	.172
3/8	3/8	C5256x6x6	11/16	7/8	1.63	.297
1/2	1/2	C5256x8x8	7/8	1-1/8	1.81	.391
3/4	3/4	C5256x12	1-1/4	1-1/4	2.08	.609
1	1	C5256x16	1-1/2	1-1/2	2.62	.844

## 45° Male Elbow Stainless Steel No. 5367x (Ref. SAE No. 070302)

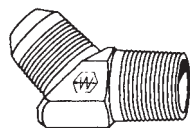
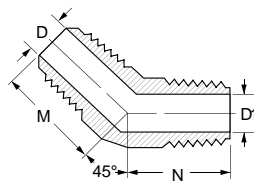
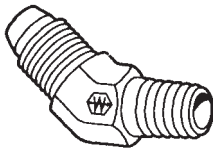

Tube O.D.	Male Pipe Thread	Catalog Number	D	D1	M	N	Across Flats
1/8	1/8	C5355x2	.062	.188	.66	.52	7/16
3/16	1/8	C5355x3	.125	.188	.66	.52	7/16
1/4	1/8	C5355x4	.172	.188	.72	.64	7/16
1/4	1/4	C5355x4x4	.172	.281	.83	.86	9/16
5/16	1/8	C5355x5	.234	.188	.77	.67	9/16
5/16	1/4	C5355x5x4	.234	.281	.83	.86	9/16
3/8	1/8	C5355x6x2	.297	.188	.83	.69	9/16
3/8	1/4	C5355x6	.297	.281	.83	.86	9/16
3/8	3/8	C5355x6x6	.297	.406	.98	.95	3/4
3/8	1/2	C5355x6x8	.297	.531	1.06	1.17	7/8
1/2	1/4	C5355x8x4	.391	.281	.98	.95	3/4
1/2	3/8	C5355x8	.391	.406	.98	.95	3/4
1/2	1/2	C5355x8x8	.391	.531	.99	1.17	7/8
5/8	3/8	C5355x10x6	.484	.406	1.11	1.00	7/8
5/8	1/2	C5355x10	.484	.531	1.11	1.17	7/8
3/4	1/2	C5355x12x8	.609	.531	1.28	1.20	1-1/16
3/4	3/4	C5355x12	.609	.719	1.28	1.20	1-1/16
1	3/4	C5355x16x12	.844	.719	1.47	1.27	1-5/16
1	1	C5355x16	.844	.938	1.47	1.48	1-5/16
1-1/4	1-1/4	C5355x20*	1.078	1.250	1.59	1.67	1-3/4
1-1/2	1-1/2	C5355x24	1.312	1.500	1.78	1.77	1-7/8
2	2	C5355x32*	1.781	1.928	2.22	2.11	2-9/16
1/8	1/8	TF5355x2	.062	.188	.66	.52	7/16
1/4	1/8	TF5355x4	.172	.188	.72	.64	1/2
1/4	1/4	TF5355x4x4	.172	.281	.81	.86	5/8
5/16	1/8	TF5355x5	.234	.188	.76	.64	9/16
5/16	1/4	TF5355x5x4	.234	.281	.83	.86	5/8
3/8	1/8	TF5355x6x2	.297	.188	.81	.66	5/8
3/8	1/4	TF5355x6	.297	.281	.82	.86	5/8
3/8	3/8	TF5355x6x6	.297	.406	.91	.95	13/16
3/8	1/2	TF5355x6x8	.297	.531	1.03	1.17	15/16
1/2	1/4	TF5355x8x4	.391	.281	.98	.94	13/16
1/2	3/8	TF5355x8	.391	.406	.98	.95	13/16
1/2	1/2	TF5355x8x8	.391	.531	1.12	1.17	15/16
5/8	3/8	TF5355x10x6	.484	.406	1.11	1.06	15/16
5/8	1/2	TF5355x10	.484	.531	1.11	1.17	15/16
5/8	3/4	TF5355x10x12	.484	.719	1.26	1.20	1-1/8
3/4	1/2	TF5355x12x8	.609	.531	1.28	1.17	1-1/8
3/4	3/4	TF5355x12	.609	.719	1.28	1.20	1-1/8
3/4	1	TF5355x12x16	.609	.938	1.42	1.48	1-3/8
1	3/4	TF5355x16x12	.844	.719	1.47	1.28	1-3/8
1	1	TF5355x16	.844	.938	1.47	1.48	1-3/8
1-1/4	1-1/4	TF5355x20	1.078	1.250	1.59	1.67	1-3/4
1-1/2	1-1/2	TF5355x24	1.312	1.500	1.78	1.77	2
2	2	TF5355x32	1.781	1.938	2.22	2.11	2-5/8

\*Special Order Only

STEEL

**Swivel Nut 45° Elbow**

**Stainless Steel No. 5368x**

(Ref. SAE No. 070321)

Example assembly No. C35356x4

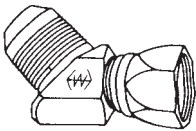
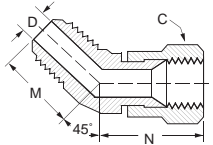
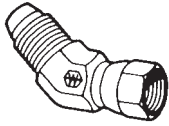

Tube O.D.	Catalog Number	Hex C	D	M	N	Across Flats
1/4	C5356x4	9/16	.172	.72	.94	7/16
5/16	C5356x5*	5/8	.234	.77	1.00	9/16
3/8	C5356x6	11/16	.297	.83	1.12	9/16
1/2	C5356x8	7/8	.391	.98	1.28	3/4
5/8	C5356x10	1	.484	1.11	1.44	7/8
3/4	C5356x12	1-1/4	.609	1.28	1.50	1-1/16
7/8	C5356x14	1-3/8	.718	1.39	1.62	1-5/16
1	C5356x16	1-1/2	.845	1.47	1.75	1-5/16
1-1/4	C5356x20*	2	1.078	1.59	2.03	1-5/8
1-1/2	C5356x24	2-1/4	1.312	1.78	2.25	1-7/8
1/4	TF5356x4	9/16	.172	.72	.94	1/2
5/16	TF5356x5	5/8	.234	.77	1.00	9/16
3/8	TF5356x6	11/16	.297	.83	1.12	5/8
1/2	TF5356x8	7/8	.391	.98	1.28	13/16
5/8	TF5356x10	1	.484	1.11	1.44	15/16
3/4	TF5356x12	1-1/4	.609	1.28	1.50	1-1/8
1	TF5356x16	1-1/2	.845	1.47	1.75	1-3/8
1-1/4	TF5356x20	2	1.078	1.59	2.03	1-3/4
1-1/2	TF5356x24	2-1/4	1.312	1.78	2.25	2
2	TF5356x32	2-7/8	1.781	2.22	2.91	2-5/8

\*Special Order Only

**45° Bulkhead Union Elbow**

(Ref. SAE No. 070801)

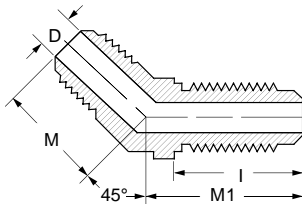
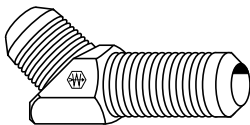

Tube O.D.	Catalog Number	D	M	M1	Across Flats	I
1/4	TF5375x4	.172	.72	1.53	1/2	1.11
5/16	TF5375x5	.234	.76	1.53	9/16	1.11
3/8	TF5375x6	.297	.83	1.67	5/8	1.18
1/2	TF5375x8	.391	.98	1.94	13/16	1.38
5/8	TF5375x10	.484	1.11	2.17	15/16	1.52
3/4	TF5375x12	.609	1.28	2.44	1-1/8	1.69
1	TF5375x16	.844	1.47	2.56	1-3/8	1.69

For Bulkhead nut see page 168. Included with assembly.

### Straight Thread O-Ring 45° Elbow

(Ref. SAE No. 070320)

Example assembly No. C35365x4

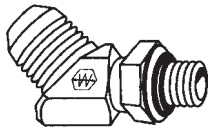
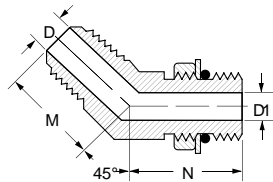
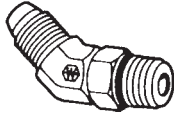

Replacement O-rings page 178.

\*Special Order Only.

Tube O.D.	Port Size	Catalog Number	D	D1	M	N	Across Flats
1/4	1/4	C5365x4	.172	.172	.72	1.05	7/16
5/16	5/16	C5365x5	.234	.234	.77	1.05	9/16
3/8	3/8	C5365x6	.297	.297	.83	1.14	9/16
1/2	1/2	C5365x8	.391	.391	.98	1.30	3/4
1/2	5/8	C5365x8x10	.391	.484	.99	1.52	7/8
5/8	5/8	C5365x10	.484	.484	1.11	1.52	7/8
3/4	5/8	C5365x12x10	.609	.484	1.28	1.57	1-1/16
3/4	3/4	C5365x12	.609	.609	1.28	1.73	1-1/16
1	1	C5365x16	.844	.844	1.47	1.86	1-5/16
1-1/4	1-1/4	C5365x20	1.078	1.078	1.59	1.91	1-5/8
1-1/2	1-1/2	C5365x24*	1.312	1.312	1.78	1.91	1-7/8
1/4	1/4	TF5365x4	.172	.172	.72	1.05	1/2
5/16	5/16	TF5365x5	.234	.234	.77	1.05	9/16
3/8	3/8	TF5365x6	.297	.297	.83	1.14	5/8
3/8	1/2	TF5365x6x8	.297	.391	.87	1.30	13/16
1/2	3/8	TF5365x8x6	.391	.297	.98	1.17	13/16
1/2	1/2	TF5365x8	.391	.391	.98	1.30	13/16
1/2	5/8	TF5365x8x10	.391	.484	.99	1.52	15/16
5/8	1/2	TF5365x10x8	.484	.391	1.09	1.41	15/16
5/8	5/8	TF5365x10	.484	.484	1.09	1.52	15/16
5/8	3/4	TF5365x10x12	.484	.609	1.22	1.73	1-1/8
3/4	5/8	TF5365x12x10	.609	.484	1.30	1.58	1-1/8
3/4	3/4	TF5365x12	.609	.609	1.28	1.73	1-1/8
3/4	1	TF5365x12x16	.609	.844	1.45	1.86	1-3/8
7/8	7/8	TF5365x14	.718	.718	1.39	1.80	1-1/4
1	3/4	TF5365x16x12	.844	.609	1.47	1.86	1-3/8
1	1	TF5365x16	.844	.844	1.47	1.86	1-3/8
1-1/4	1-1/4	TF5365x20	1.078	1.250	1.59	1.91	1-3/4
1-1/2	1-1/2	TF5365x24	1.312	1.312	1.78	1.91	2
2	2	TF5365x32	1.781	1.938	2.22	1.86	2-5/8

### 90° Union Elbow

Stainless Steel No. 5517x

(Ref. SAE No. 070201)

Example assembly No. C35505x4

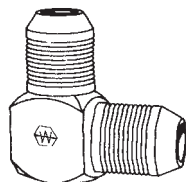
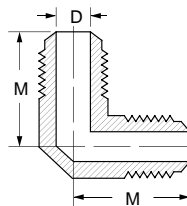
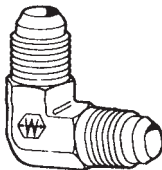

\*Special Order Only

Tube O.D.	Catalog Number	D	M	Across Flats
1/4	C5505x4	.172	.89	7/16
5/16	C5505x5*	.234	.95	9/16
3/8	C5505x6	.297	1.06	9/16
1/2	C5505x8	.391	1.25	3/4
5/8	C5505x10	.484	1.45	7/8
3/4	C5505x12	.609	1.66	1-1/16
1	C5505x16	.844	1.81	1-5/16
1-1/4	C5505x20*	1.078	2.06	1-5/8
1-1/2	C5505x24*	1.312	2.33	1-7/8
1/4	TF5505x4	.172	.89	1/2
5/16	TF5505x5	.234	.95	1/2
3/8	TF5505x6	.297	1.06	5/8
1/2	TF5505x8	.391	1.25	13/16
5/8	TF5505x10	.484	1.45	15/16
3/4	TF5505x12	.609	1.66	1-1/8
7/8	TF5505x14	.718	1.73	1-1/4
1	TF5505x16	.844	1.81	1-3/8
1-1/4	TF5505x20	1.078	2.06	1-3/4
1-1/2	TF5505x24	1.312	2.33	2
2	TF5505x32	1.781	3.06	2-5/8

## 90° Male Elbow

Stainless Steel No. 5417x

(Ref. SAE No. 070202)

Example assembly No. C35405x4

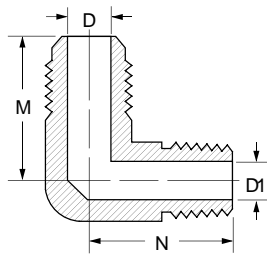
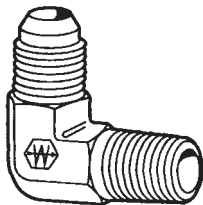

Tube O.D.	Male Pipe Thread	Catalog Number	D	D1	M	N	Across Flats
1/8	1/8	C5405x2	.062	.188	.77	.72	7/16
3/16	1/8	C5405x3	.125	.188	.83	.72	7/16
1/4	1/8	C5405x4	.172	.188	.89	.78	7/16
1/4	1/4	C5405x4x4	.172	.281	1.05	1.09	9/16
5/16	1/8	C5405x5	.234	.188	.95	.78	9/16
5/16	1/4	C5405x5x4	.234	.281	1.05	1.09	9/16
3/8	1/8	C5405x6x2	.297	.188	1.06	.90	9/16
3/8	1/4	C5405x6	.297	.281	1.06	1.09	9/16
3/8	3/8	C5405x6x6	.297	.406	1.14	1.22	3/4
3/8	1/2	C5405x6x8	.297	.531	1.22	1.47	7/8
1/2	1/4	C5405x8x4	.391	.281	1.25	1.22	3/4
1/2	3/8	C5405x8	.391	.406	1.25	1.22	3/4
1/2	1/2	C5405x8x8	.391	.531	1.33	1.47	7/8
1/2	3/4	C5405x8x12	.391	.719	1.42	1.59	1-1/16
5/8	3/8	C5405x10x6	.484	.406	1.45	1.28	7/8
5/8	1/2	C5405x10	.484	.531	1.45	1.47	7/8
5/8	3/4	C5405x10x12	.484	.719	1.54	1.59	1-1/16
3/4	1/2	C5405x12x8	.609	.531	1.66	1.59	1-1/16
3/4	3/4	C5405x12	.609	.719	1.66	1.59	1-1/16
7/8	3/4	C5405x14*	.719	.719	1.73	1.69	1-5/16
1	3/4	C5405x16x12	.844	.719	1.81	1.78	1-5/16
1	1	C5405x16	.844	.938	1.81	1.97	1-5/16
1-1/4	1	C5405x20x16	1.078	.938	2.06	2.38	1-5/8
1-1/4	1-1/4	C5405x20	1.078	1.250	2.06	2.38	1-5/8
1-1/2	1-1/2	C5405x24	1.312	1.500	2.33	2.64	1-7/8
2	2	C5405x32	1.781	1.938	3.06	3.00	2-9/16
1/4	1/8	TF5405x4	.172	.188	.89	.78	1/2
1/4	1/4	TF5405x4x4	.172	.281	.95	1.09	5/8
1/4	3/8	TF5405x4x6	.172	.406	1.05	1.22	13/16
1/4	1/2	TF5405x4x8	.172	.531	1.11	1.47	15/16
5/16	1/8	TF5405x5	.234	.188	.95	.78	9/16
5/16	1/4	TF5405x5x4	.234	.281	.98	1.09	5/8
5/16	3/8	TF5405x5x6	.234	.406	1.08	1.22	13/16
3/8	1/8	TF5405x6x2	.297	.188	1.06	.81	5/8
3/8	1/4	TF5405x6	.297	.281	1.06	1.09	5/8
3/8	3/8	TF5405x6x6	.297	.406	1.16	1.22	13/16
3/8	1/2	TF5405x6x8	.297	.531	1.22	1.47	15/16
3/8	3/4	TF5405x6x12	.297	.719	1.31	1.59	1-1/8
1/2	1/4	TF5405x8x4	.391	.281	1.25	1.19	13/16
1/2	3/8	TF5405x8	.391	.406	1.25	1.22	13/16
1/2	1/2	TF5405x8x8	.391	.531	1.31	1.47	15/16
1/2	3/4	TF5405x8x12	.391	.719	1.41	1.59	1-1/8
5/8	3/8	TF5405x10x6	.484	.406	1.45	1.28	15/16
5/8	1/2	TF5405x10	.484	.531	1.45	1.47	15/16
5/8	3/4	TF5405x10x12	.484	.719	1.55	1.59	1-1/8
3/4	1/2	TF5405x12x8	.609	.531	1.66	1.56	1-1/8
3/4	3/4	TF5405x12	.609	.719	1.66	1.59	1-1/8
3/4	1	TF5405x12x16	.609	.938	1.78	1.97	1-3/8
7/8	3/4	TF5405x14	.718	.719	1.73	1.69	1-1/4
1	3/4	TF5405x16x12	.844	.719	1.81	1.72	1-3/8
1	1	TF5405x16	.844	.938	1.81	1.97	1-3/8
1	1-1/4	TF5405x16x20	.844	1.250	2.00	2.37	1-3/4
1-1/4	1	TF5405x20x16	1.078	.938	2.06	2.16	1-3/4
1-1/4	1-1/4	TF5405x20	1.078	1.250	2.06	2.37	1-3/4
1-1/4	1-1/2	TF5405x20x24	1.078	1.500	2.19	2.64	2
1-1/2	1-1/4	TF5405x24x20	1.312	1.250	2.33	2.50	2
1-1/2	1-1/2	TF5405x24	1.312	1.500	2.33	2.64	2
2	2	TF5405x32	1.781	1.938	3.06	3.00	2-5/8

\*Special Order Only

### 90° Male Elbow Long (Ref. SAE No. 071502)

Example assembly No. C35425x4

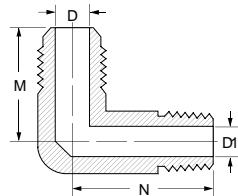
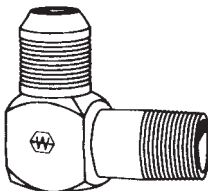
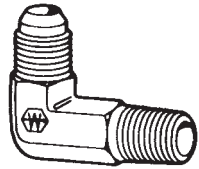

\*Special Order Only.

Tube O.D.	Male Pipe Thread	Catalog Number	D	D1	M	N	Across Flats
1/4	1/4	C5425x4x4*	.172	.281	1.05	1.58	9/16
3/8	1/4	C5425x6	.297	.281	1.06	1.58	9/16
1/2	3/8	C5425x8*	.391	.406	1.25	1.82	3/4
3/4	3/4	C5425x12	.609	.719	1.66	2.44	1-1/16
1/4	1/8	TF5425x4	.172	.188	.89	1.17	1/2
1/4	1/4	TF5425x4x4	.172	.281	.95	1.58	5/8
5/16	1/4	TF5425x5x4	.234	.281	.95	1.55	9/16
3/8	1/4	TF5425x6	.297	.281	1.06	1.58	5/8
3/8	3/8	TF5425x6x6	.297	.406	1.16	1.83	13/16
1/2	3/8	TF5425x8	.391	.406	1.25	1.83	13/16
1/2	1/2	TF5425x8x8	.391	.531	1.31	2.17	15/16
1/2	3/4	TF5425x8x12	.391	.719	1.41	2.44	1-1/8
5/8	1/2	TF5425x10	.484	.531	1.45	2.17	15/16
3/4	3/4	TF5425x12	.609	.719	1.66	2.44	1-1/8
7/8	3/4	TF5425x14x12	.718	.719	1.73	2.66	1-1/4
1	1	TF5425x16	.844	.938	1.81	3.02	1-3/8
1-1/4	1-1/4	TF5425x20	1.078	1.250	2.06	3.69	1-3/4
1-1/2	1-1/2	TF5425x24	1.312	1.500	2.32	4.11	2

### 90° Male Elbow Extra Long (Ref. SAE No. 071602)

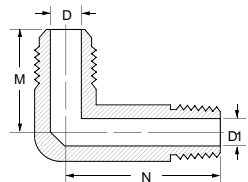
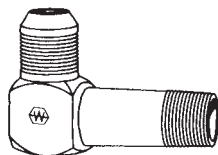

Tube O.D.	Male Pipe Thread	Catalog Number	D	D1	M	N	Across Flats
1/4	1/8	TF5435x4	.172	.188	.89	1.56	1/2
1/4	1/4	TF5435x4x4	.172	.281	.95	2.07	5/8
5/16	1/8	TF5435x5	.234	.188	.95	1.62	9/16
5/16	1/4	TF5435x5x4	.234	.281	.95	2.04	9/16
3/8	1/4	TF5435x6	.297	.281	1.06	2.08	5/8
3/8	3/8	TF5435x6x6	.297	.406	1.06	2.42	13/16
1/2	3/8	TF5435x8	.391	.406	1.25	2.42	13/16
1/2	1/2	TF5435x8x8	.391	.531	1.31	2.88	15/16
5/8	1/2	TF5435x10	.484	.531	1.45	2.88	15/16
3/4	3/4	TF5435x12	.609	.719	1.66	3.28	1-1/8
7/8	3/4	TF5435x14	.718	.719	1.73	3.62	1-1/4
1	1	TF5435x16	.844	.938	1.81	4.05	1-3/8
1-1/4	1-1/4	TF5435x20	1.078	1.250	2.06	5.00	1-3/4

### Bulkhead Union Elbow Stainless Steel No. 5537x (Ref. SAE No. 070701)

Example assembly No. C35525x4

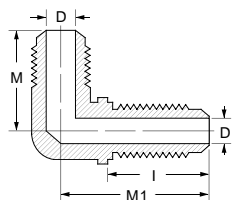
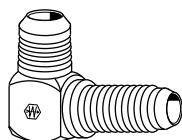
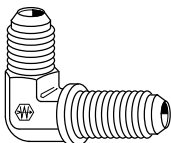

\*Special Order Only.  
For Bulkhead nut see page 162. Included with assembly.

Tube O.D.	Catalog Number	D	I	M	M1	Across Flats
1/4	C5525x4	.172	1.11	.97	1.59	7/16
5/16	C5525x5*	.234	1.11	1.03	1.62	9/16
3/8	C5525x6	.297	1.18	1.09	1.81	9/16
1/2	C5525x8	.391	1.38	1.36	2.11	3/4
5/8	C5525x10*	.484	1.52	1.56	2.39	7/8
3/4	C5525x12	.609	1.69	1.78	2.67	1-1/16
1	C5525x16	.844	1.69	1.94	2.80	1-5/16
1-1/4	C5525x20	1.078	1.74	2.17	3.12	1-5/8
1/4	TF5525x4	.172	1.11	.97	1.59	1/2
5/16	TF5525x5	.234	1.11	1.03	1.62	9/16
3/8	TF5525x6	.297	1.18	1.09	1.81	5/8
1/2	TF5525x8	.391	1.38	1.36	2.11	13/16
5/8	TF5525x10	.484	1.52	1.56	2.39	15/16
3/4	TF5525x12	.609	1.69	1.78	2.67	1-1/8
1	TF5525x16	.844	1.69	1.94	2.80	1-3/8

## 90° Female Elbow

Stainless Steel No. **5467x**

(Ref. SAE No. 070203)

Example assembly No. **C35455x4**

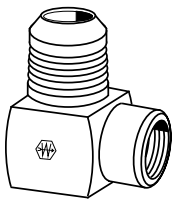
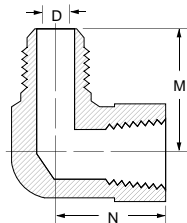
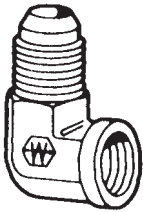

\*Special Order Only.

Tube O.D.	Fem. Pipe Thread	Catalog Number	D	M	N	Across Flats
1/4	1/8	<b>C5455x4</b>	.172	1.08	.66	9/16
1/4	1/4	<b>C5455x4x4*</b>	.172	1.22	.88	3/4
5/16	1/8	<b>C5455x5*</b>	.234	1.08	.66	9/16
3/8	1/8	<b>C5455x6x2</b>	.297	1.06	.66	9/16
3/8	1/4	<b>C5455x6</b>	.297	1.23	.88	3/4
3/8	3/8	<b>C5455x6x6</b>	.297	1.31	1.02	7/8
1/2	1/4	<b>C5455x8x4</b>	.391	1.23	.88	3/4
1/2	3/8	<b>C5455x8</b>	.391	1.42	1.02	7/8
1/2	1/2	<b>C5455x8x8</b>	.391	1.52	1.23	1-1/16
5/8	1/2	<b>C5455x10</b>	.484	1.64	1.23	1-1/16
3/4	1/2	<b>C5455x12x8</b>	.609	1.66	1.23	1-1/16
3/4	3/4	<b>C5455x12</b>	.609	1.89	1.36	1-5/16
7/8	3/4	<b>C5455x14</b>	.718	1.86	1.42	1-5/16
1	1	<b>C5455x16</b>	.844	2.17	1.62	1-5/8
1-1/4	1-1/4	<b>C5455x20*</b>	1.078	2.33	1.70	1-7/8
1/4	1/8	<b>TF5455x4</b>	.172	1.08	.66	5/8
1/4	1/4	<b>TF5455x4x4</b>	.172	1.14	.88	3/4
5/16	1/8	<b>TF5455x5</b>	.234	1.08	.66	5/8
5/16	1/4	<b>TF5455x5x4</b>	.234	1.30	1.02	7/8
3/8	1/4	<b>TF5455x6</b>	.297	1.23	.88	3/4
3/8	3/8	<b>TF5455x6x6</b>	.297	1.14	.88	3/4
1/2	3/8	<b>TF5455x8</b>	.391	1.42	1.02	7/8
1/2	1/2	<b>TF5455x8x8</b>	.391	1.55	1.23	1-1/8
5/8	1/2	<b>TF5455x10</b>	.484	1.64	1.23	1-1/8
3/4	3/4	<b>TF5455x12</b>	.609	1.89	1.36	1-3/8
7/8	3/4	<b>TF5455x14</b>	.718	1.86	1.42	1-3/8
1	1	<b>TF5455x16</b>	.814	2.17	1.62	1-5/8
1-1/4	1-1/4	<b>TF5455x20</b>	1.078	2.33	1.70	2
1-1/2	1-1/2	<b>TF5455x24</b>	1.312	2.89	2.08	2-3/8
2	2	<b>TF5455x32</b>	1.781	3.30	2.39	2-7/8

## Swivel Nut 90° Elbow

Stainless Steel No. **5518x**

(Ref. SAE No. 070221)

Example assembly No. **C35506x4**

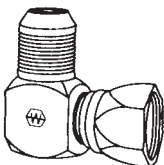
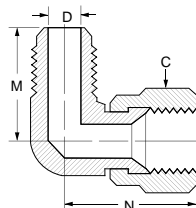
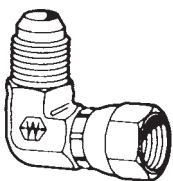

\*Special Order Only.

Tube O.D.	Catalog Number	Hex C	D	M	N	Across Flats
1/4	<b>C5506x4</b>	9/16	.172	.89	1.00	7/16
5/16	<b>C5506x5</b>	5/8	.234	.95	1.06	9/16
3/8	<b>C5506x6</b>	11/16	.297	1.06	1.25	9/16
1/2	<b>C5506x8</b>	7/8	.391	1.25	1.42	3/4
5/8	<b>C5506x10</b>	1	.484	1.43	1.62	7/8
3/4	<b>C5506x12</b>	1-1/4	.609	1.66	1.75	1-1/16
7/8	<b>C5506x14*</b>	1-3/8	.718	1.73	1.72	1-5/16
1	<b>C5506x16</b>	1-1/2	.844	1.81	2.00	1-5/16
1-1/4	<b>C5506x20</b>	2	1.078	2.06	2.31	1-5/8
1/4	<b>TF5506x4</b>	9/16	.172	.89	1.00	1/2
5/16	<b>TF5506x5</b>	5/8	.234	.95	1.06	9/16
3/8	<b>TF5506x6</b>	11/16	.297	1.06	1.25	5/8
1/2	<b>TF5506x8</b>	7/8	.391	1.25	1.38	13/16
5/8	<b>TF5506x10</b>	1	.484	1.45	1.62	15/16
3/4	<b>TF5506x12</b>	1-1/4	.609	1.66	1.75	1-1/8
7/8	<b>TF5506x14</b>	1-3/8	.718	1.73	1.78	1-1/4
1	<b>TF5506x16</b>	1-1/2	.844	1.81	2.00	1-3/8
1-1/4	<b>TF5506x20</b>	2	1.078	2.06	2.31	1-3/4
1-1/2	<b>TF5506x24</b>	2-1/4	1.312	2.33	2.59	2
2	<b>TF5506x32</b>	2-7/8	1.781	3.06	3.38	2-5/8

# SAE 37° Flare-Twin®

**Steel Fittings**

## 90° Male Pipe to 37° SAE Swivel

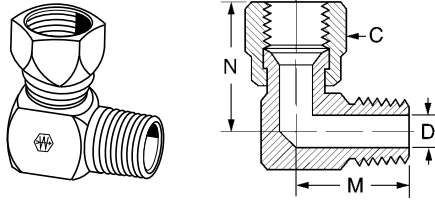

Tube O.D.	Male Pipe	Catalog Number	D	M	N	Across Flats	Hex C
1/4	1/8	TF5406x4	.188	.78	1.00	1/2	9/16
3/8	1/4	TF5406x6	.281	1.09	1.25	5/8	11/16
1/2	3/8	TF5406x8	.406	1.22	1.38	13/16	7/8
5/8	1/2	TF5406x10	.531	1.47	1.62	15/16	1
3/4	3/4	TF5406x12	.719	1.59	1.75	1-1/8	1-1/4
1	1	TF5406x16	.938	1.97	2.00	1-3/8	1-1/2
1-1/4	1-1/4	TF5406x20	1.250	2.38	2.31	1-3/4	2
1-1/2	1-1/2	TF5406x24	1.500	2.64	2.59	2	2-1/4
2	2	TF5406x32	1.938	3.00	3.38	2-5/8	2-7/8

## Straight Thread O-Ring 90° Elbow

Stainless Steel No. **5527x**  
(Ref. SAE No. 070220)  
Example assembly No. **C35515x4**

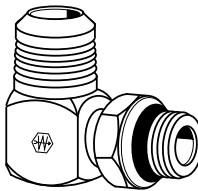
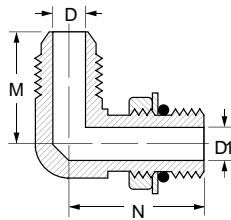
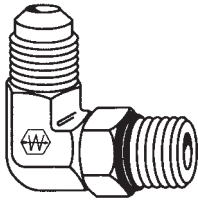

Tube O.D.	Port Size	Catalog Number	D	D1	M	N	Across Flats
3/16	3/16	C5515x3	.125	.125	.83	.94	7/16
1/4	1/4	C5515x4	.172	.172	.89	1.03	7/16
5/16	5/16	C5515x5	.234	.234	.95	1.13	9/16
3/8	3/8	C5515x6	.297	.297	1.06	1.25	9/16
3/8	1/2	C5515x6x8	.297	.391	1.14	1.45	3/4
1/2	3/8	C5515x8x6	.391	.297	1.25	1.32	3/4
1/2	1/2	C5515x8	.391	.391	1.25	1.45	3/4
1/2	5/8	C5515x8x10	.391	.484	1.33	1.70	7/8
5/8	5/8	C5515x10	.484	.484	1.45	1.70	7/8
3/4	5/8	C5515x12x10	.609	.484	1.66	1.78	1-1/16
3/4	3/4	C5515x12	.609	.609	1.66	1.94	1-1/16
7/8	7/8	C5515x14	.718	.718	1.73	2.00	1-5/16
1	3/4	C5515x16x12	.844	.609	1.81	2.05	1-5/16
1	1	C5515x16	.844	.844	1.81	2.05	1-5/16
1-1/4	1-1/4	C5515x20	1.078	1.078	2.06	2.25	1-5/8
1-1/2	1-1/2	C5515x24	1.312	1.312	2.33	2.39	1-7/8
1/4	1/4	TF5515x4	.172	.172	.89	1.03	1/2
1/4	5/16	TF5515x4x5	.172	.234	.95	1.12	5/8
1/4	3/8	TF5515x4x6	.172	.297	.95	1.25	5/8
5/16	1/4	TF5515x5x4	.234	.172	.98	1.06	9/16
5/16	5/16	TF5515x5	.234	.234	.95	1.09	9/16
5/16	3/8	TF5515x5x6	.234	.297	.98	1.25	5/8
3/8	1/4	TF5515x6x4	.297	.172	1.06	1.09	5/8
3/8	5/16	TF5515x6x5	.297	.234	1.06	1.12	5/8
3/8	3/8	TF5515x6	.297	.297	1.06	1.25	5/8
3/8	1/2	TF5515x6x8	.297	.391	1.16	1.45	13/16
3/8	5/8	TF5515x6x10	.297	.484	1.22	1.70	15/16
1/2	3/8	TF5515x8x6	.391	.297	1.25	1.34	13/16
1/2	1/2	TF5515x8	.391	.391	1.25	1.45	13/16
1/2	5/8	TF5515x8x10	.391	.484	1.31	1.70	15/16
1/2	3/4	TF5515x8x12	.391	.609	1.41	1.94	1-1/8
5/8	1/2	TF5515x10x8	.484	.391	1.45	1.52	15/16
5/8	5/8	TF5515x10	.484	.484	1.45	1.70	15/16
5/8	3/4	TF5515x10x12	.484	.609	1.55	1.94	1-1/8
3/4	1/2	TF5515x12x8	.609	.391	1.66	1.61	1-1/8
3/4	5/8	TF5515x12x10	.609	.484	1.66	1.80	1-1/8
3/4	3/4	TF5515x12	.609	.609	1.66	1.94	1-1/8
3/4	7/8	TF5515x12x14	.609	.718	1.72	2.00	1-1/4
3/4	1	TF5515x12x16	.609	.844	1.78	2.05	1-3/8
7/8	7/8	TF5515x14	.718	.718	1.73	2.00	1-5/16
1	3/4	TF5515x16x12	.844	.609	1.81	2.06	1-3/8
1	7/8	TF5515x16x14	.844	.718	1.81	2.06	1-3/8
1	1	TF5515x16	.844	.844	1.81	2.05	1-3/8
1	1-1/4	TF5515x16x20	.844	1.078	2.00	2.25	1-3/4
1-1/4	1	TF5515x20x16	1.078	.844	2.06	2.23	1-3/4
1-1/4	1-1/4	TF5515x20	1.078	1.078	2.06	2.25	1-3/4
1-1/2	1-1/4	TF5515x24x20	1.312	1.078	2.33	2.37	2
1-1/2	1-1/2	TF5515x24	1.312	1.312	2.33	2.39	2
2	2	TF5515x32	1.781	1.781	3.06	2.89	2-5/8

Replacement O-rings page 178.

STEEL

## Straight Thread O-Ring 90° Elbow Long

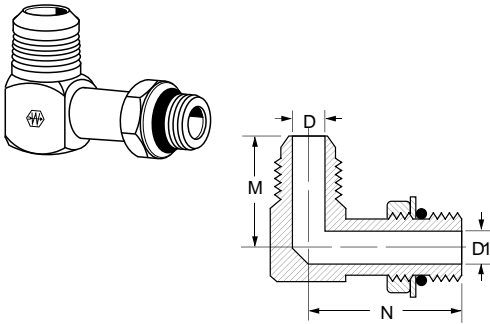

Replacement O-rings page 178.

Tube O.D.	Port Size	Catalog Number	D	D1	M	N	Across Flats
3/8	3/8	TF5515x6L	.297	.297	1.06	1.66	5/8
1/2	1/2	TF5515x8L	.391	.391	1.25	1.81	13/16
5/8	5/8	TF5515x10L	.484	.484	1.45	2.16	15/16
3/4	3/4	TF5515x12L	.609	.609	1.66	2.47	1-1/8

## Straight Thread O-Ring 90° Elbow Extra Long

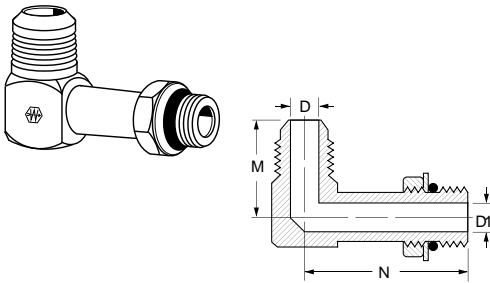

Replacement O-rings page 178.

Tube O.D.	Port Size	Catalog Number	D	D1	M	N	Across Flats
3/8	3/8	TF5515x6LL	.297	.297	1.06	2.08	5/8
1/2	1/2	TF5515x8LL	.391	.391	1.25	2.50	13/16
5/8	5/8	TF5515x10LL	.484	.484	1.45	3.25	15/16
3/4	3/4	TF5515x12LL	.609	.609	1.66	3.34	1-1/8

## Union Tee Stainless Steel No. 5717x (Ref. SAE No. 070401) Assembly No. C35705x4

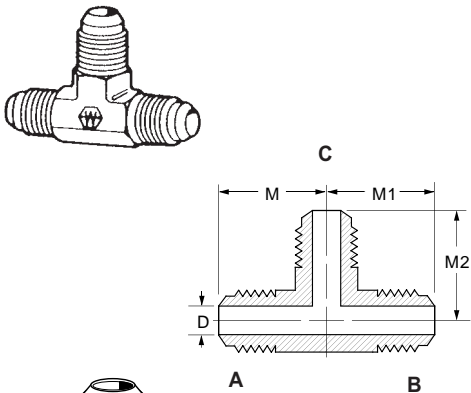

\*Special Order Only.

Tube O.D. A	Tube O.D. B	Tube O.D. C	Catalog Number	D	M	M1	M2	Across Flats
1/8	1/8	1/8	C5705x2	.062	.77	.77	.77	7/16
3/16	3/16	3/16	C5705x3	.125	.83	.83	.83	7/16
1/4	1/4	1/4	C5705x4	.172	.89	.89	.89	7/16
5/16	5/16	5/16	C5705x5*	.234	.95	.95	.95	9/16
3/8	3/8	3/8	C5705x6	.297	1.06	1.06	1.06	9/16
1/2	1/2	1/2	C5705x8	.391	1.25	1.25	1.25	3/4
5/8	5/8	5/8	C5705x10	.484	1.45	1.45	1.45	7/8
3/4	3/4	3/4	C5705x12	.609	1.66	1.66	1.66	1-1/16
7/8	7/8	7/8	C5705x14	.718	1.73	1.73	1.73	1-5/16
1	1	1	C5705x16	.844	1.81	1.81	1.81	1-5/16
1-1/4	1-1/4	1-1/4	C5705x20	1.078	2.06	2.06	2.06	1-5/8
1-1/2	1-1/2	1-1/2	C5705x24	1.312	2.33	2.33	2.33	1-7/8
1/4	1/4	1/4	TF5705x4	.172	.89	.89	.89	1/2
5/16	5/16	5/16	TF5705x5	.234	.95	.95	.95	1/2
3/8	3/8	3/8	TF5705x6	.297	1.06	1.06	1.06	5/8
1/2	1/2	1/2	TF5705x8	.391	1.25	1.25	1.25	13/16
5/8	1/2	1/2	TF5705x10x8x8	.484	1.45	1.31	1.31	15/16
5/8	5/8	5/8	TF5705x10	.484	1.45	1.45	1.45	15/16
5/8	5/8	1/2	TF5705x10x10x8	.484	1.45	1.45	1.31	15/16
3/4	3/4	3/4	TF5705x12	.609	1.66	1.66	1.66	1-1/8
7/8	7/8	7/8	TF5705x14	.718	1.73	1.73	1.73	1-1/4
1	1	1	TF5705x16	.844	1.81	1.81	1.81	1-3/8
1-1/4	1-1/4	1-1/4	TF5705x20	1.078	2.06	2.06	2.06	1-3/4
1-1/2	1-1/2	1-1/2	TF5705x24	1.312	2.33	2.33	2.33	1-7/8
2	2	2	TF5705x32	1.781	3.06	3.06	3.06	2-5/8



### Male Run Tee

Stainless Steel No. **5767x**

(Ref. SAE No. 070424)

Example assembly No. **C35755x4**

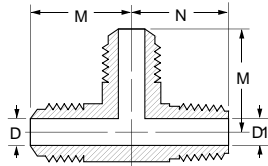
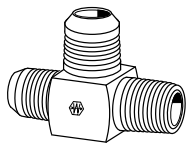
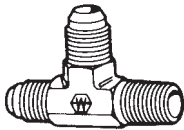

\*Special Order Only

Tube O.D.	Male Pipe Thread	Catalog Number	D	D1	M	N	Across Flats
1/4	1/8	<b>C5755x4</b>	.172	.188	.89	.78	7/16
1/4	1/4	<b>C5755x4x4x4*</b>	.172	.281	1.05	1.09	9/16
3/8	1/4	<b>C5755x6</b>	.297	.281	1.06	1.09	9/16
1/2	3/8	<b>C5755x8</b>	.391	.406	1.25	1.22	3/4
1/2	1/2	<b>C5755x8x8x8*</b>	.391	.531	1.33	1.47	7/8
5/8	1/2	<b>C5755x10</b>	.484	.531	1.45	1.47	7/8
3/4	3/4	<b>C5755x12</b>	.609	.719	1.66	1.59	1-1/16
1	1	<b>C5755x16</b>	.844	.938	1.81	1.97	1-5/16
1/4	1/8	<b>TF5755x4</b>	.172	.188	.89	.78	1/2
1/4	1/4	<b>TF5755x4x4x4</b>	.172	.281	.95	1.09	9/16
5/16	1/8	<b>TF5755x5</b>	.234	.188	.95	.78	1/2
3/8	1/4	<b>TF5755x6</b>	.297	.281	1.06	1.09	9/16
3/8	3/8	<b>TF5755x6x6x6</b>	.297	.406	1.16	1.22	9/16
1/2	3/8	<b>TF5755x8</b>	.391	.406	1.25	1.22	13/16
1/2	1/2	<b>TF5755x8x8x8</b>	.391	.531	1.31	1.47	7/8
5/8	1/2	<b>TF5755x10</b>	.484	.531	1.45	1.47	15/16
3/4	3/4	<b>TF5755x12</b>	.609	.719	1.66	1.59	1-1/8
7/8	3/4	<b>TF5755x14</b>	.718	.719	1.73	1.69	1-1/4
1	1	<b>TF5755x16</b>	.844	.938	1.81	1.97	1-3/8
1-1/4	1-1/4	<b>TF5755x20</b>	1.078	1.250	2.06	2.38	1-3/4
1-1/2	1-1/2	<b>TF5755x24</b>	1.312	1.500	2.33	2.64	2
2	2	<b>TF5755x32</b>	1.781	1.938	3.06	3.00	2-5/8

### Female Run Tee

(Ref. SAE No. 070426)

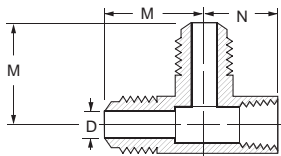
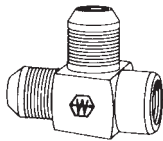

Tube O.D.	Fem. Pipe Thread	Catalog Number	D	M	N	Across Flats
1/4	1/8	<b>TF5805x4</b>	.172	1.08	.66	5/8
3/8	1/4	<b>TF5805x6</b>	.297	1.23	.88	3/4
1/2	3/8	<b>TF5805x8</b>	.391	1.42	1.02	7/8
5/8	1/2	<b>TF5805x10</b>	.484	1.64	1.23	1-1/8
3/4	3/4	<b>TF5805x12</b>	.609	1.89	1.36	1-3/8
7/8	3/4	<b>TF5805x14</b>	.718	1.86	1.42	1-3/8
1	1	<b>TF5805x16</b>	.844	2.17	1.62	1-5/8

### Swivel Nut Run Tee

Stainless Steel No. **5718x**

(Ref. SAE No. 070432)

Example assembly No. **C35706x4**

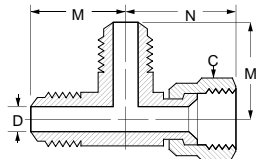
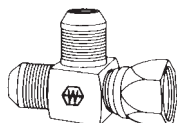
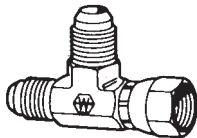

Tube O.D.	Catalog Number	Hex C	D	M	N	Across Flats
1/4	<b>C5706x4</b>	9/16	.172	.89	1.00	7/16
5/16	<b>C5706x5</b>	5/8	.234	.95	1.06	9/16
3/8	<b>C5706x6</b>	11/16	.297	1.06	1.25	9/16
1/2	<b>C5706x8</b>	7/8	.391	1.25	1.44	3/4
5/8	<b>C5706x10</b>	1	.484	1.45	1.62	7/8
3/4	<b>C5706x12</b>	1-1/4	.609	1.66	1.75	1-1/16
1	<b>C5706x16</b>	1-1/2	.844	1.81	2.00	1-5/16
1-1/4	<b>C5706x20</b>	2	1.078	2.06	2.36	1-5/8
1/4	<b>TF5706x4</b>	9/16	.172	.89	1.00	1/2
5/16	<b>TF5706x5</b>	5/8	.234	.95	1.06	9/16
3/8	<b>TF5706x6</b>	11/16	.297	1.06	1.25	5/8
1/2	<b>TF5706x8</b>	7/8	.391	1.25	1.38	13/16
5/8	<b>TF5706x10</b>	1	.484	1.45	1.62	15/16
3/4	<b>TF5706x12</b>	1-1/4	.609	1.66	1.75	1-1/8
7/8	<b>TF5706x14</b>	1-3/8	.719	1.73	1.78	1-1/4
1	<b>TF5706x16</b>	1-1/2	.844	1.81	2.00	1-3/8
1-1/4	<b>TF5706x20</b>	2	1.078	2.06	2.31	1-3/4
1-1/2	<b>TF5706x24</b>	2-1/4	1.312	2.33	2.59	2
2	<b>TF5706x32</b>	2-7/8	1.781	3.06	3.38	2-5/8

**Bulkhead Run Tee**  
(Ref. SAE No. 070958)

Example assembly No. C35726x6

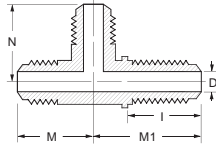
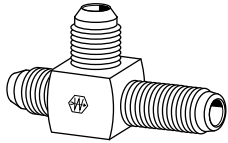

For Bulkhead nut see page 162.  
Included with assembly.

Tube O.D.	Catalog Number	D	I	N	M	M1	Across Flats
3/8	C5726x6	.297	1.18	1.09	1.06	1.81	9/16
1/2	TF5726x8	.391	1.38	1.36	1.36	2.11	3/4

**Straight Thread O-Ring Run Tee**  
(Ref. SAE No. 070428)

Example assembly No. C35716x4

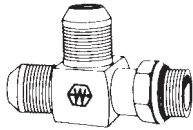
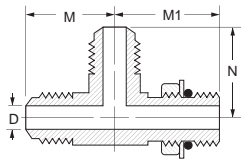
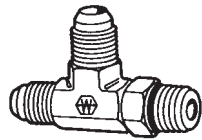

Replacement O-rings page 178.

Tube O.D.	Port Size	Catalog Number	D	M	M1	Across Flats	N
1/4	1/4	C5716x4	.172	.89	1.03	7/16	.89
5/16	5/16	C5716x5	.234	.95	1.09	9/16	.95
3/8	3/8	C5716x6	.297	1.06	1.25	9/16	1.06
1/2	1/2	C5716x8	.391	1.25	1.45	3/4	1.25
5/8	5/8	C5716x10	.484	1.45	1.70	7/8	1.45
3/4	3/4	C5716x12	.609	1.66	1.94	1-1/16	1.66
1	1	C5716x16	.844	1.81	2.05	1-5/16	1.81
1-1/4	1-1/4	C5716x20	1.078	2.06	2.25	1-5/8	2.06
1/4	1/4	TF5716x4	.172	.89	1.03	1/2	.89
5/16	5/16	TF5716x5	.234	.95	1.09	9/16	.95
3/8	3/8	TF5716x6	.297	1.06	1.25	5/8	1.06
1/2	1/2	TF5716x8	.391	1.25	1.45	13/16	1.25
5/8	5/8	TF5716x10	.484	1.45	1.70	15/16	1.45
3/4	3/4	TF5716x12	.609	1.66	1.94	1-1/8	1.66
7/8	7/8	TF5716x14	.718	1.73	2.00	1-1/4	1.73
1	1	TF5716x16	.844	1.81	2.05	1-3/8	1.81
1-1/4	1-1/4	TF5716x20	1.078	2.06	2.25	1-3/4	2.06
1-1/2	1-1/2	TF5716x24	1.312	2.33	2.39	2	2.33

**Male Branch Tee**  
Stainless Steel No. 5617x  
(Ref. SAE No. 070425)  
Example assembly No. C35605x4

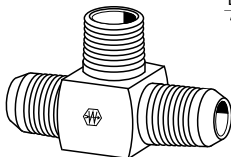
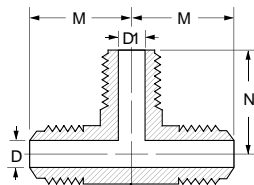
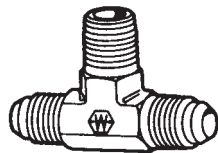

Tube O.D.	Male Pipe Thread	Catalog Number	D	D1	M	N	Across Flats
1/4	1/8	C5605x4	.172	.188	.89	.78	7/16
1/4	1/4	C5605x4x4x4	.172	.281	1.05	1.09	9/16
5/16	1/8	C5605x5	.234	.188	.95	.78	9/16
3/8	1/4	C5605x6	.297	.281	1.06	1.09	9/16
1/2	3/8	C5605x8	.391	.406	1.25	1.22	3/4
5/8	1/2	C5605x10	.484	.531	1.45	1.47	7/8
3/4	3/4	C5605x12	.609	.719	1.66	1.59	1-1/16
7/8	3/4	C5605x14*	.718	.719	1.73	1.69	1-5/16
1	1	C5605x16	.844	.938	1.81	1.97	1-5/16
1-1/4	1-1/4	C5605x20*	1.078	1.250	2.06	2.38	1-5/8
1/4	1/8	TF5605x4	.172	.188	.89	.78	1/2
1/4	1/4	TF5605x4x4x4	.172	.281	.95	1.09	5/8
5/16	1/8	TF5605x5	.234	.188	.95	.78	9/16
3/8	1/4	TF5605x6	.297	.281	1.08	1.09	5/8
3/8	3/8	TF5605x6x6x6	.297	.406	1.16	1.22	13/16
1/2	3/8	TF5605x8	.391	.406	1.25	1.22	13/16
1/2	1/2	TF5605x8x8x8	.391	.531	1.31	1.47	15/16
5/8	1/2	TF5605x10	.484	.531	1.45	1.47	15/16
3/4	3/4	TF5605x12	.609	.719	1.66	1.59	1-1/8
7/8	3/4	TF5605x14	.718	.719	1.73	1.69	1-1/4
1	1	TF5605x16	.844	.938	1.81	1.97	1-3/8
1-1/4	1-1/4	TF5605x20	1.078	1.250	2.06	2.38	1-3/4
1-1/2	1-1/2	TF5605x24	1.312	1.500	2.33	2.64	2
2	2	TF5605x32	1.781	1.938	3.06	3.00	2-5/8

\*Special Order Only

**Female Branch Tee**  
**Stainless Steel No. 5667x**  
 (Ref. SAE No. 070427)  
 Example assembly No. C35655x4

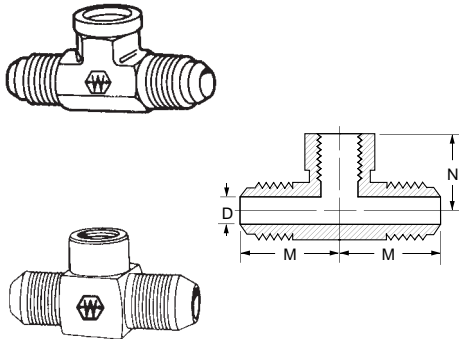

\*Special Order Only

Tube O.D.	Fem. Pipe Thread	Catalog Number	D	M	N	Across Flats
1/4	1/8	C5655x4	.172	1.08	.66	9/16
3/8	1/4	C5655x6*	.297	1.23	.88	3/4
1/2	3/8	C5655x8*	.391	1.42	1.02	7/8
5/8	1/2	C5655x10	.484	1.64	1.23	1-1/16
3/4	3/4	C5655x12	.609	1.89	1.36	1-5/16
1	1	C5655x16*	.844	2.17	1.62	1-5/8
1/4	1/8	TF5655x4	.172	1.08	.66	5/8
1/4	1/4	TF5655x4x4x4	.172	1.14	.88	3/4
5/16	1/8	TF5655x5	.234	1.08	.66	5/8
3/8	1/4	TF5655x6	.297	1.23	.88	3/4
3/8	3/8	TF5655x6x6x6	.297	1.30	1.02	7/8
1/2	3/8	TF5655x8	.391	1.42	1.02	7/8
1/2	1/2	TF5655x8x8x8	.391	1.55	1.23	1-1/8
5/8	1/2	TF5655x10	.484	1.64	1.23	1-1/8
3/4	3/4	TF5655x12	.609	1.89	1.36	1-3/8
7/8	3/4	TF5655x14	.718	1.86	1.42	1-3/8
1	1	TF5655x16	.844	2.17	1.62	1-5/8
1-1/4	1-1/4	TF5655x20	1.078	2.33	1.70	2
1-1/2	1-1/2	TF5655x24	1.312	2.89	2.08	2-3/8
2	2	TF5655x32	1.781	3.30	2.39	2-7/8

**Swivel Nut Branch Tee**  
**Stainless Steel No. 5719x**  
 (Ref. SAE No. 070433)  
 Example assembly No. C35707x4

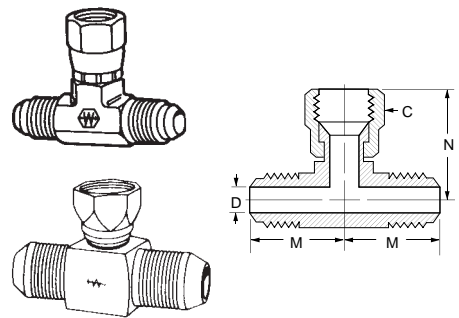

\*Special Order Only

Tube O.D.	Catalog Number	Hex C	D	M	N	Across Flats
1/4	C5707x4*	9/16	.172	.89	1.00	7/16
3/8	C5707x6	11/16	.297	1.06	1.25	9/16
1/2	C5707x8*	7/8	.391	1.25	1.43	3/4
5/8	C5707x10*	1	.484	1.45	1.62	7/8
3/4	C5707x12	1-1/4	.609	1.66	1.75	1-1/16
1	C5707x16	1-1/2	.844	1.81	2.00	1-5/16
1/4	TF5707x4	9/16	.172	.89	1.00	7/16
5/16	TF5707x5	5/8	.234	.95	1.06	9/16
3/8	TF5707x6	11/16	.297	1.06	1.25	5/8
1/2	TF5707x8	7/8	.391	1.25	1.38	13/16
5/8	TF5707x10	1	.484	1.45	1.62	7/8
3/4	TF5707x12	1-1/4	.609	1.66	1.75	1-1/8
7/8	TF5707x14	1-3/8	.719	1.73	1.78	1-1/4
1	TF5707x16	1-1/2	.844	1.81	2.00	1-3/8
1-1/4	TF5707x20	2	1.078	2.06	2.31	2
1-1/2	TF5707x24	2-1/4	1.312	2.33	2.59	2
2	TF5707x32	2-7/8	1.781	3.06	3.38	2-5/8

**Bulkhead Union Tee**  
 (Ref. SAE No. 070959)

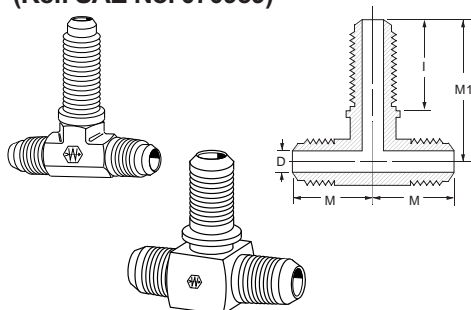

#Stainless Steel Construction  
 For bulkhead nut see page 162. Included with assembly.

\*Special Order Only

Tube O.D.	Catalog Number	I	D	M	M1	Across Flats
1/4	TF5725x4	1.11	.172	.97	1.59	1/2
3/8	TF5725x6	1.18	.297	1.06	1.81	5/8
1/2	TF5725x8	1.38	.391	1.36	2.11	13/16
5/8	TF5725x10	1.52	.484	1.56	2.39	15/16
3/4	TF5725x12	1.69	.609	1.78	2.67	1-1/8
1	TF5725x16	1.69	.844	1.94	2.80	1-3/8
1/4	5737x4#	1.11	.172	.97	1.59	7/16
3/8	5737x6#	1.18	.297	1.09	1.81	9/16

**Straight Thread O-Ring Branch Tee**

(Ref. SAE No. 070429)

Example assembly No. C35715x4

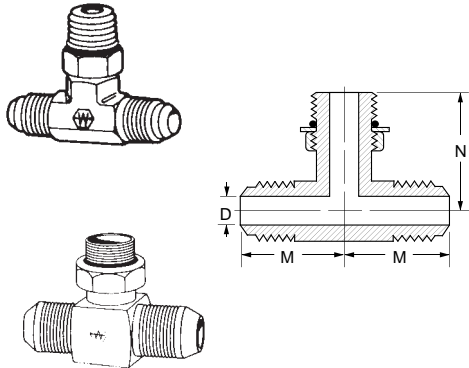

Replacement O-rings listed below.  
\*Special Order Only.

Tube O.D.	Port Size	Catalog Number	D	M	N	Across Flats
1/4	1/4	C5715x4	.172	.89	1.03	7/16
5/16	5/16	C5715x5*	.234	.95	1.09	9/16
3/8	3/8	C5715x6	.297	1.06	1.25	9/16
1/2	1/2	C5715x8	.391	1.25	1.45	3/4
5/8	5/8	C5715x10	.484	1.45	1.70	7/8
3/4	3/4	C5715x12	.609	1.66	1.94	1-1/16
1	1	C5715x16	.844	1.81	2.05	1-5/16
1/4	1/4	TF5715x4	.172	.89	1.03	7/16
5/16	5/16	TF5715x5	.234	.95	1.09	9/16
3/8	3/8	TF5715x6	.297	1.06	1.25	5/8
1/2	1/2	TF5715x8	.391	1.25	1.45	3/4
5/8	5/8	TF5715x10	.484	1.45	1.70	15/16
3/4	3/4	TF5715x12	.609	1.66	1.94	1-1/8
7/8	7/8	TF5715x14	.719	1.73	2.00	1-1/4
1	1	TF5715x16	.844	1.81	2.05	1-3/8
1-1/4	1-1/4	TF5715x20	1.078	2.06	2.25	1-3/4
1-1/2	1-1/2	TF5715x24	1.312	2.33	2.39	2

**Cross**

(Ref. SAE No. 070501)

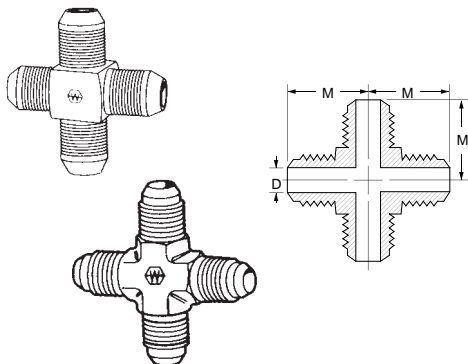

#Stainless Steel Construction

Tube O.D.	Catalog Number	D	M	Across Flats
1/4	TF5955x4	.172	.89	1/2
5/16	TF5955x5	.234	.95	9/16
3/8	TF5955x6	.297	1.06	5/8
1/2	TF5955x8	.391	1.25	13/16
5/8	TF5955x10	.484	1.45	15/16
3/4	TF5955x12	.609	1.66	1-1/8
7/8	TF5955x14	.718	1.73	1-1/4
1	TF5955x16	.844	1.81	1-3/8
1-1/4	TF5955x20	1.078	2.06	1-3/4
1-1/2	TF5955x24	1.312	2.33	2
1/4	5967x4#	.172	.89	7/16
3/8	5967x6#	.297	1.06	9/16
1/2	5967x8#	.391	1.25	3/4

**Straight Thread O-Ring**

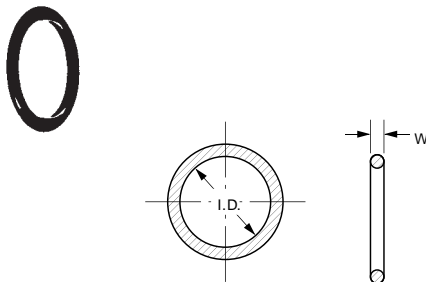

**Material:** Buna-N 90 Durometer  
**Temperature Range:** -40°F to +250°F  
 (-40°C to +121°C)  
 Standard O-ring complies with SAE specification  
 SAE J515 Type CH.

Tube O.D.	Catalog Number	W	I.D.
1/16	7629x1	.058	.185
1/8	7629x2	.064	.239
3/16	7629x3	.064	.301
1/4	7629x4	.072	.351
5/16	7629x5	.072	.414
3/8	7629x6	.078	.468
7/16	7629x7	.082	.530
1/2	7629x8	.087	.644
5/8	7629x10	.097	.755
3/4	7629x12	.116	.924
7/8	7629x14	.116	1.048
1	7629x16	.116	1.171
1-1/4	7629x20	.118	1.475
1-1/2	7629x24	.118	1.720
2	7629x32	.118	2.337

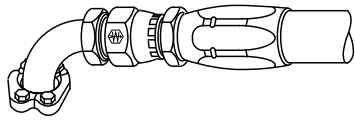

### Adapter Used With Standard Female Swivel End (SAE Code 61)

Weatherhead® split flange adapter eliminates the need for special hose ends. Interconnect pumps and valves with SAE flange outlets using low cost standard hose assemblies to replace equipment hose assembly.

**Material:** Low carbon steel.

**Plating:** Zinc, Yellow Dichromate finish.

**Pressure:** Code 61 – 3000 PSI working pressure (32 sizes 2500 PSI W.P.).

**Label Set:** FS-300.

**Note:** See page 254 for hydraulic O-ring assortment

### Straight

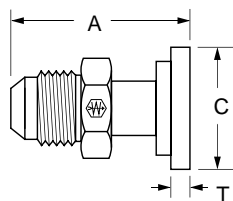

Tube Size	Code 61 Flange Size	Catalog Number	A	Dia. C	T	Thread Size
1/2	1/2	50008	2.66	1.188	.265	3/4-16
1/2	3/4	50008x12	2.72	1.500	.265	3/4-16
3/4	3/4	50012	2.62	1.500	.265	1 1/16-12
1	1	50016	2.74	1.750	.315	1 5/16-12
1	1-1/4	50016x20	2.74	2.000	.315	1 5/16-12
1-1/4	1	50020x16	2.80	1.750	.315	1 5/8-12
1-1/4	1-1/4	50020	3.27	2.000	.315	1 5/8-12
1-1/2	1-1/2	50024	3.42	2.375	.315	1 7/8-12
2	2	50032	4.24	2.812	.375	2 1/2-12

### 45° Elbow

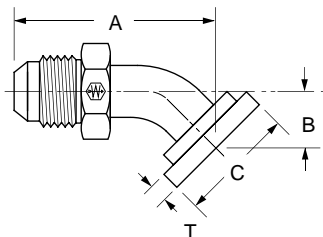

Tube Size	Code 61 Flange Size	Catalog Number	A	B	Dia. C	T	Thread Size
1/2	1/2	54508	2.91	.78	1.188	.265	3/4-16
1/2	3/4	54508x12	2.93	.84	1.500	.265	3/4-16
3/4	3/4	54512	3.28	1.03	1.500	.265	1 1/16-12
1	1	54516	3.61	1.06	1.750	.315	1 5/16-12
1	1-1/4	54516x20	3.61	1.06	2.000	.315	1 5/16-12
1-1/4	1	54520x16	3.67	1.06	1.750	.315	1 5/8-12
1-1/4	1-1/4	54520	3.36	1.15	2.000	.315	1 5/8-12
1-1/2	1-1/2	54524	4.61	1.41	2.375	.315	1 7/8-12
2	2	54532	6.28	2.00	2.812	.375	2 1/2-12

### 90° Elbow

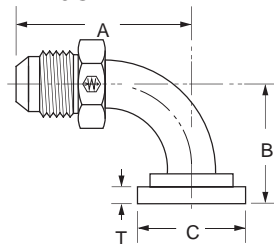

Tube Size	Code 61 Flange Size	Catalog Number	A	B	Dia. C	T	Thread Size
1/2	1/2	59008	2.54	1.63	1.188	.265	3/4-16
1/2	3/4	59008x12	2.54	1.69	1.500	.265	3/4-16
3/4	3/4	59012	2.79	2.19	1.500	.265	1 1/16-12
1	1	59016	3.61	2.38	1.750	.315	1 5/16-12
1	1-1/4	59016x20	3.61	2.38	2.000	.315	1 5/16-12
1-1/4	1	59020x16	3.66	2.38	1.750	.315	1 5/8-12
1-1/4	1-1/4	59020	3.52	2.62	2.000	.315	1 5/8-12
1-1/2	1-1/2	59024	4.32	3.12	2.375	.315	1 7/8-12
2	2	59032	5.95	4.50	2.812	.375	2 1/2-12

### Split Flange Kits – SAE Standard Pressure Series (Code 61) SAE J518

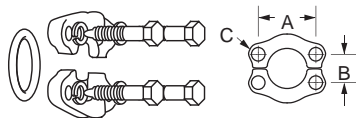

**Material:** Buna-N 90 Durometer  
**Temperature Range:** -40°F to +250°F (-40°C to +121°C)

Standard O-ring complies with SAE specifications SAE J515 Type CH (See page 165 for O-ring compound and application chart)

Nominal Flange Size	Catalog Number Complete Kit	Flange Halves 2 Req'd.		Lock Washer	Bolt Torque Range Lb.-in.	Lock Washer			
		O-Ring	Boots			A	B	C	
1/2	SFK-08	8x251	8x252	8x853	8x254	1.50	.69	11/32	175-225
3/4	SFK-12	12x251	12x252	12x853	12x254	1.88	.88	13/32	250-350
1	SFK-16	16x251	16x252	16x853	16x254	2.06	1.03	13/32	325-425
1-1/4	SFK-20	20x251	20x252	20x853	20x254	2.31	1.19	15/32	425-550
1-1/2	SFK-24	24x251	24x252	24x853	24x254	2.75	1.41	17/32	550-700
2	SFK-32	32x251	32x252	24x853	24x254	3.06	1.69	17/32	650-800

Flanges conform to SAE J518.

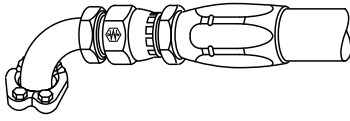

## Adapter Used With Standard Female Swivel End (SAE Code 62)

Weatherhead® split flange adapter eliminates the need for special hose ends. Interconnect pumps and valves with SAE flange outlets using low cost standard hose assemblies to replace original equipment hose assembly.

**Material:** AISI/SAE 12L14 carbon steel.

**Plating:** Zinc, Yellow Dichromate finish.

**Pressure:** Code 62 – 5000 PSI working pressure.

**Label Set:** FS-300

**Note:** See page 254 for hydraulic O-ring assortment.

### Straight

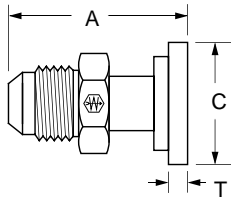

Tube Size	Code 62 Flange Size	Catalog Number	A	Dia. C	T	Thread Size
1/2	1/2	60008	2.32	1.25	.305	3/4-16
3/4	3/4	60012	2.64	1.62	.345	1 1/16-12
1	1	60016	3.44	1.88	.375	1 5/16-12
1-1/4	1-1/4	60020	3.97	2.12	.405	1 5/8-12
1-1/2	1-1/2	60024	4.97	2.50	.495	1 7/8-12
2	2	60032	5.22	3.12	.495	2 1/2-12

### 45° Elbow

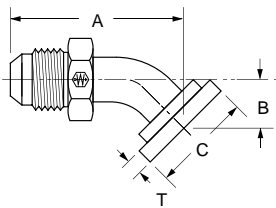

Tube Size	Code 62 Flange Size	Catalog Number	A	B	Dia. C	T	Thread Size
1/2	1/2	64508	2.12	1.10	1.25	.305	3/4-16
3/4	3/4	64512	2.56	1.32	1.62	.345	1 1/16-12
1	1	64516	3.34	1.43	1.88	.375	1 5/16-12
1-1/4	1-1/4	64520	3.49	1.87	2.12	.405	1 5/8-12
1-1/2	1-1/2	64524	6.31	3.07	2.50	.495	1 7/8-12
2	2	64532	8.19	3.74	3.12	.495	2 1/2-12

### 90° Elbow

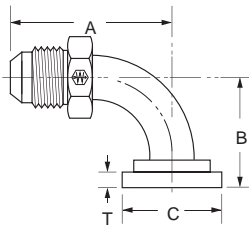

Tube Size	Code 62 Flange Size	Catalog Number	A	B	Dia. C	T	Thread Size
1/2	1/2	69008	1.57	2.11	1.25	.305	3/4-16
3/4	3/4	69012	1.93	2.56	1.62	.345	1 1/16-12
1	1	69016	2.35	2.90	1.88	.375	1 5/16-12
1-1/4	1-1/4	69020	2.91	3.46	2.12	.405	1 5/8-12
1-1/2	1-1/2	69024	5.44	6.53	2.50	.495	1 7/8-12
2	2	69032	7.38	8.22	3.12	.495	2 1/2-12

## Split Flange Kits – SAE High Pressure Series (Code 62) SAE J518

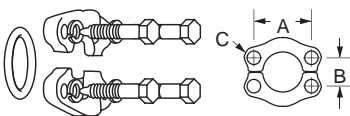

**Material:** Buna-N 90 Durometer  
**Temperature Range:** -40°F to +250°F  
 (-40°C to +121°C)

Standard O-ring complies with SAE specifications SAE J515 Type CH (See page 165 for O-ring compound and application chart)

Nominal Flange Size	Catalog Number Complete Kit	Flange Halves 2 Req'd.	O-Ring	Lock Bolts	Washer	A	B	C	Bolt Torque Range Lb.-in.
1/2	SFK62-8	8x262	8x252	8x863	8x254	1.57	.72	5/16	175-225
3/4	SFK62-12	12x262	12x252	12x863	12x254	2.00	.94	13/32	300-400
1	SFK62-16	16x262	16x252	16x863	16x254	2.25	1.09	15/32	500-600
1-1/4	SFK62-20	20x262	20x252	20x863	20x254	2.63	1.25	17/32	750-900
1-1/2	SFK62-24	24x262	24x252	24x863	24x264	3.12	1.44	21/32	1400-1600
2	SFK62-32	32x262	32x252	32x863	32x264	3.81	1.75	25/32	2400-2600

Flanges conform to SAE J518.

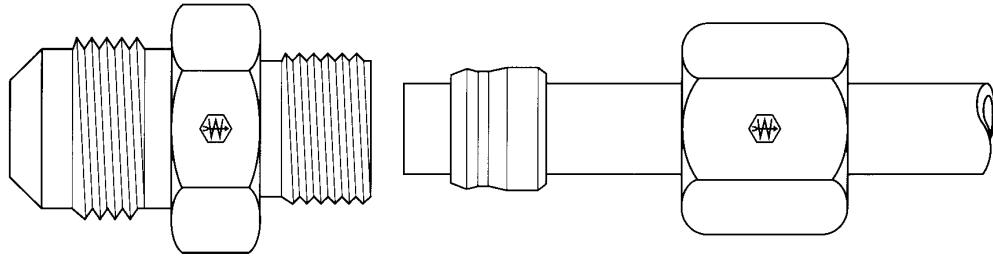

Metric Tube O.D.	6	8	10	12	14	15	16	18	20	22	25	28	30	38
Light	M12x1.5	M14x1.5	M16x1.5	M18x1.5	–	M22x1.5	–	M26x1.5	–	M30x2.0	–	M36x2.0	–	–
Heavy	M14x1.5	M16x1.5	M18x1.5	M20x1.5	M22x1.5	–	M24x1.5	–	M30x2.0	–	M36x2.0	–	M42x2.0	M52x2.0

- **Typical Application**

Used in applications to adapt connections made to DIN (Deutsche Industrie Norme) specifications to male 37° SAE Flare.

- **Sealing Method**

Three-Piece Flareless Bite Type or 60° or 24° Tube Seat, or 37° Flare.

- **Vibration Rating**

Three-Piece Flareless Bite Type or 60° or 24° Tube Seat. Fair Resistance.

- **Material**

Carbon Steel - SAE 12L14

- **Plating**

Bodies and Sleeves - Zinc Yellow Dichromate Finish  
Nuts - Phosphate Coating.

- **Advantages**

Provides an adapter to convert a metric hose assembly to SAE 37° allowing the use of standard hose and end fittings. Can also be used in the repair of metric tubing.

- **Presetting Instructions**

1. Cut the tubing squarely and lightly deburr the end of the tubing inside and out.
2. Lubricate the sleeve, nut and threads with a good grade of lubricant compatible with the system fluid.
3. Slide the nut and sleeve on the tubing. The thicker end of the sleeve should be towards the nut.
4. Insert the tube into the preset tool making sure it is bottomed on the tube stop. Tighten the nut by hand as much as possible.

5. On the tube sizes up to and including 18mm O.D., tighten the nut 1-1/2 turns past hand tight. For larger tube O.D.'s, tighten the nut 1-1/4 turns past hand tight.
6. To inspect preset, mark the nut location and remove nut. The sleeve should be covering 70% to 80% of the sleeve face thickness.
7. To reinstall, tighten the nut 1/6 turn (one hex flat) past the previous nut location.

- **Ordering Information**

Order individually by catalog number. Preset tools found on page 223.

**NOTE:** Multiply millimeters (mm) by 0.03937 to obtain inches.

## Metric Flareless Sleeve

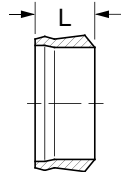
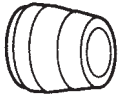

Tube O.D. (mm)	Catalog Number	L (mm)
6	7165x6MM	8.5
8	7165x8MM	8.5
10	7165x10MM	9.5
12	7165x12MM	9.5
14	7165x14MM	10.0
15	7165x15MM	10.0
16	7165x16MM	10.0
18	7165x18MM	10.0
20	7165x20MM	11.5
22	7165x22MM	11.5
25	7165x25MM	11.5
28	7165x28MM	11.5
30	7165x30MM	13.5
38	7165x38MM	13.5

## Metric Flareless Nut Light Series (DIN 3901/3902L)

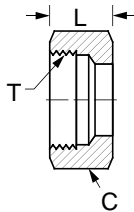
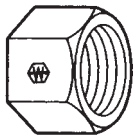

Tube O.D. (mm)	Catalog Number	T Thread	Hex C (mm)	L (mm)
6	ML7105x6	M12x1.5	14	14.5
8	ML7105x8	M14x1.5	17	14.5
10	ML7105x10	M16x1.5	19	15.5
12	ML7105x12	M18x1.5	22	15.5
15	ML7105x15	M22x1.5	27	17.0
18	ML7105x18	M26x1.5	32	18.0
22	ML7105x22	M30x2.0	36	20.0
28	ML7105x28	M36x2.0	41	21.0

## Metric Flareless Nut Heavy Series (DIN 3901/3902S)

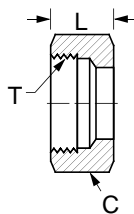
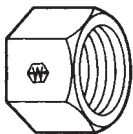

Tube O.D. (mm)	Catalog Number	T Thread	Hex C (mm)	L (mm)
6	MH7105x6	M14x1.5	17	16.5
8	MH7105x8	M16x1.5	19	16.5
10	MH7105x10	M18x1.5	22	17.5
12	MH7105x12	M20x1.5	24	17.5
14	MH7105x14	M22x1.5	27	20.5
16	MH7105x16	M24x1.5	30	20.5
20	MH7105x20	M30x2.0	36	24.0
25	MH7105x25	M36x2.0	46	27.0
30	MH7105x30	M42x2.0	50	29.0
38	MH7105x38	M52x2.0	60	32.5

NOTE: Multiply millimeters (mm) by 0.03937 to obtain inches.



### Male SAE 37° to 24° Metric Tube Seat (Light) (DIN 3901/3902L)

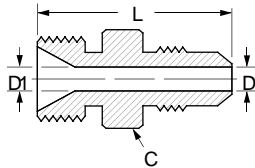
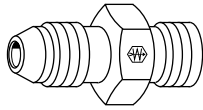

Tube O.D.	Tube O.D. (mm)	Catalog Number	Metric Thread	Hex C	D	D1	L
1/4	6	MC5206x4x6	M12x1.5	5/8	.171	.171	1.22
3/8	8	MC5206x6x8	M14x1.5	3/4	.297	.240	1.22
1/2	10	MC5206x8x10	M16x1.5	7/8	.391	.322	1.41
1/2	12	MC5206x8x12	M18x1.5	15/16	.391	.398	1.48
5/8	15	MC5206x10x15	M22x1.5	1-1/16	.484	.478	1.70
3/4	18	MC5206x12x18	M26x1.5	1-3/4	.609	.596	1.91

### Male SAE 37° to 24° Metric Tube Seat (Heavy) (DIN 3901/3902S)

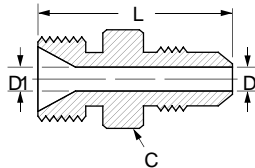
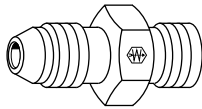

Tube O.D.	Tube O.D. (mm)	Catalog Number	Metric Thread	Hex C	D	D1	L
3/8	6	MC5208x6x6	M14x1.5	3/4	.297	.167	1.22
1/2	10	MC5208x8x10	M18x1.5	15/16	.391	.283	1.48
5/8	14	MC5208x10x14	M22x1.5	1-1/16	.484	.397	1.70
3/4	16	MC5208x12x16	M24x1.5	1-1/8	.609	.476	1.77

### Male SAE 37° to 60° Metric Tube Seat (DIN 7631)

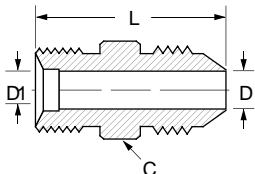
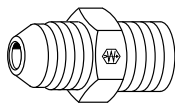

Tube O.D.	Tube O.D. (mm)	Catalog Number	Metric Thread	Hex C	D	D1	L
1/4	6	MC5207x4x6	M12x1.5	1/2	.171	.157	1.22
3/8	8	MC5207x6x8	M14x1.5	5/8	.297	.242	1.22
3/8	10	MC5207x6x10	M16x1.5	7/8	.297	.321	1.32
1/2	12	MC5207x8x12	M18x1.5	15/16	.391	.394	1.48
5/8	15	MC5207x10x15	M22x1.5	1-1/16	.472	.472	1.52
3/4	18	MC5207x12x18	M26x1.5	1-1/8	.609	.596	1.91

### Male 37° SAE to Male Metric Standpipe (DIN 7631)

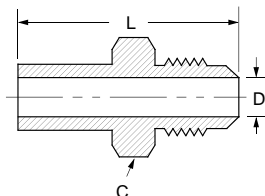
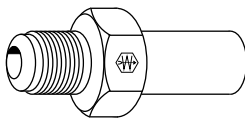

Tube O.D.	Port Size	Catalog Number	Hex C	L	D
1/4	6MM	MC5019x4x6	9/16	1.58	.16
1/4	8MM	MC5019x4x8	9/16	1.68	.17
3/8	10MM	MC5019x6x10	3/4	1.67	.28
1/2	12MM	MC5019x8x12	7/8	1.97	.32
1/2	14MM	MC5019x8x14	7/8	1.89	.39
5/8	15MM	MC5019x10x15	1	2.03	.43
5/8	16MM	MC5019x10x16	1	2.07	.47
3/4	16MM	MC5019x12x16	1-1/4	2.22	.47
3/4	18MM	MC5019x12x18	1-1/4	2.12	.55
3/4	20MM	MC5019x12x20	1-1/4	2.38	.61
1	22MM	MC5019x16x22	1-1/2	2.21	.67
1	25MM	MC5019x16x25	1-1/2	2.54	.79

NOTE: Multiply millimeters (mm) by 0.03937 to obtain inches.

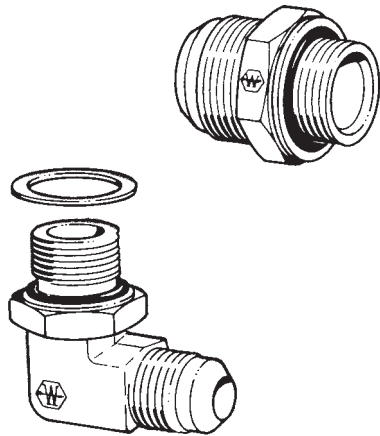

- **Typical Application**  
Used in applications to adapt connections and tubing to male and female swivel 37° SAE flare.
- **Sealing Method**  
Tapered pipe thread, or o-ring, or 37° flare.
- **Vibration Rating**  
Fair resistance.
- **Material**  
Carbon Steel – SAE 12L14.
- **Plating**  
Zinc yellow dichromate finish.
- **Advantages**  
Provides an adapter to convert Metric ports to 37° SAE allowing the use of standard hose and end fittings. Also metric tubing that can be flared can be adapted to a standard 37° SAE connection by the use of sleeves.
- **Ordering Information**  
Order individually by catalog number.

**Sleeve 3 Piece Metric  
(Ref. SAE No. 070115)**

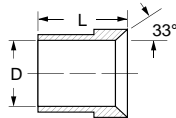
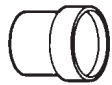

Adapts standard SAE Flare-Twin® fittings for use with metric tubing.

Tube O.D. (Inch Size)	Tube O.D. (Metric Size)	Catalog Number	D	L
1/4	6MM	C5165x4x6MM	.241	.41
5/16	8MM	C5165x5x8MM	.320	.44
3/8	10MM	C5165x6x10MM	.399	.50
1/2	12MM	C5165x8x12MM	.478	.56
5/8	14MM	C5165x10x14MM	.556	.66
5/8	15MM	C5165x10x15MM	.596	.66
5/8	16MM	C5165x10x16MM	.636	.66
3/4	18MM	C5165x12x18MM	.717	.68
7/8	20MM	C5165x14x20MM	.793	.76
7/8	22MM	C5165x14x22MM	.866	.76
1	25MM	C5165x16x25MM	.990	.78
1-1/4	30MM	C5165x20x30MM	1.191	.91
1-1/4	32MM	C5165x20x32MM	1.270	.91
1-1/2	38MM	C5165x24x38MM	1.500	1.12

**Male 37° SAE to Male Metric  
Straight Thread Connector  
(Port Per ISO 9974)**

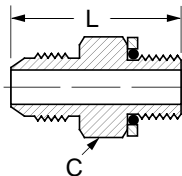

Replacement retaining rings and O-rings page 185.

Tube O.D.	Male Metric Thread	Catalog Number	L	Hex C
1/4	M10x1.0	MC5315x4x10	1.18	5/8
1/4	M12x1.5	MC5315x4x12	1.22	5/8
1/4	M14x1.5	MC5315x4x14	1.22	3/4
3/8	M14x1.5	MC5315x6x14	1.22	3/4
3/8	M16x1.5	MC5315x6x16	1.32	7/8
1/2	M18x1.5	MC5315x8x18	1.48	15/16
1/2	M22x1.5	MC5315x8x22	1.61	1-1/16
5/8	M20x1.5	MC5315x10x20	1.71	1
3/4	M22x1.5	MC5315x12x22	1.81	1-1/8
3/4	M27x2.0	MC5315x12x27	1.95	1-1/4
1	M33x2.0	MC5315x16x33	2.03	1-5/8
1-1/4	M42x2.0	MC5315x20x42	2.19	2

NOTE: Multiply millimeters (mm) by 0.03937 to obtain inches.

### Female 37° SAE Swivel to Male Metric Taper Pipe Thread (Pipe Thread Per DIN 158)

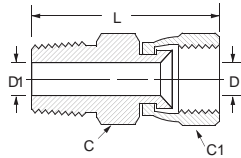
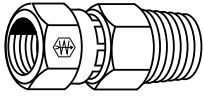

Tube O.D.	Metric Taper Pipe Thread	Catalog Number	Hex C	Hex C1	D	D1	L
1/4	R1/4-19	<a href="#">M9700x4x6</a>	9/16	9/16	.172	.172	1.25
5/16	R3/8-19	<a href="#">M9700x5x8</a>	11/16	5/8	.234	.234	1.54
3/8	R1/2-14	<a href="#">M9700x6x10</a>	11/16	11/16	.297	.297	1.60
1/2	R3/4-14	<a href="#">M9700x8x12</a>	7/8	7/8	.391	.391	1.78
5/8	R1-11	<a href="#">M9700x10x14</a>	1	1	.484	.484	1.91
3/4	R1-1/4-11	<a href="#">M9700x12x20</a>	1-1/8	1-1/8	.609	.609	2.04
1	R1-1/2-11	<a href="#">M9700x16x25</a>	1-3/8	1-1/2	.845	.845	2.30
1-1/4	R2-11	<a href="#">M9700x20x32</a>	1-7/8	2	1.079	1.079	2.43

### Male 37° SAE to Male Metric Straight Thread 90° Elbow (For ISO 9974 Port)

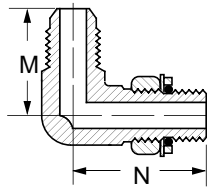
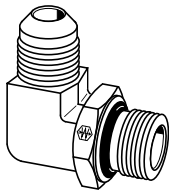

Replacement retaining rings and O-rings see below.

Tube O.D.	Male Metric Thread	Catalog Number	M	N
1/4	M10x1.0	<a href="#">MC5515x4x10</a>	.89	1.03
1/4	M12x1.5	<a href="#">MC5515x4x12</a>	.95	1.09
3/8	M14x1.5	<a href="#">MC5515x6x14</a>	1.06	1.25
3/8	M16x1.5	<a href="#">MC5515x6x16</a>	1.14	1.45
1/2	M18x1.5	<a href="#">MC5515x8x18</a>	1.26	1.47
1/2	M22x1.5	<a href="#">MC5515x8x22</a>	1.33	1.70
5/8	M18x1.5	<a href="#">MC5515x10x18</a>	1.41	1.60
5/8	M20x1.5	<a href="#">MC5515x10x20</a>	1.45	1.70
5/8	M22x1.5	<a href="#">MC5515x10x22</a>	1.45	1.70
3/4	M22x1.5	<a href="#">MC5515x12x22</a>	1.66	1.78
3/4	M27x2.0	<a href="#">MC5515x12x27</a>	1.66	1.94
1	M33x2.0	<a href="#">MC5515x16x33</a>	1.81	2.05

### Metric Retaining Ring

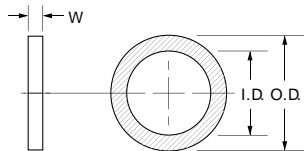

Tube O.D. (mm)	Catalog Number	Ring I.D. (mm)	Ring O.D. (mm)	W (mm)
10	<a href="#">M7630x10</a>	11.33	14.85	1.00
12	<a href="#">M7630x12</a>	13.72	17.85	1.42
14	<a href="#">M7630x14</a>	15.73	19.85	1.42
16	<a href="#">M7630x16</a>	17.73	21.85	1.42
18	<a href="#">M7630x18</a>	19.73	23.80	1.42
20	<a href="#">M7630x20</a>	21.73	25.85	1.42
22	<a href="#">M7630x22</a>	23.73	27.85	1.42
27	<a href="#">M7630x27</a>	29.44	32.85	1.90
33	<a href="#">M7630x33</a>	35.44	39.85	1.90
42	<a href="#">M7630x42</a>	44.44	49.85	1.90

### Metric O-Ring (For ISO 9974 Port)

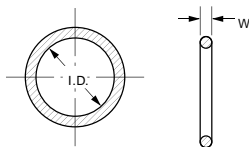

**Material:** Buna N 90 Durometer  
**Temperature Range:** -40°F to +250°F (-40°C to +121°C)

Tube O.D.	Catalog Number	W (mm)	I.D. (mm)
10	<a href="#">M7629x10</a>	1.60	8.10
12	<a href="#">M7629x12</a>	2.40	9.30
14	<a href="#">M7629x14</a>	2.10	11.40
16	<a href="#">M7629x16</a>	2.40	13.30
18	<a href="#">M7629x18</a>	2.40	15.60
20	<a href="#">M7629x20</a>	2.46	18.00
22	<a href="#">M7629x22</a>	2.46	19.80
27	<a href="#">M7629x27</a>	2.95	23.47
33	<a href="#">M7629x33</a>	2.95	29.74
42	<a href="#">M7629x42</a>	3.00	39.20

NOTE: Multiply millimeters (mm) by 0.03937 to obtain inches.

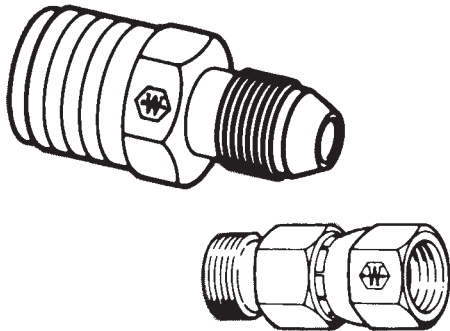

- Typical Application**  
 Used in applications to adapt connections made to BSP (British Standard Pipe) specifications to male or female swivel SAE 37° flare.
- Sealing Method**  
 Tapered (BSPT) or Parallel Pipe Thread (BSPP), O-ring or 37° flare.
- Vibration Rating**  
 Fair resistance.
- Material**  
 Carbon Steel – SAE 12L14.
- Plating**  
 Zinc with yellow dichromate finish.
- Advantages**  
 Provides an adapter to convert BSP ports to 37° SAE allowing the use of standard hose and end fittings.
- Ordering Information**  
 Order individually by catalog number.

<b>Pipe Size</b>	1/8	1/4	3/8	1/2	5/8	3/4	1	1-1/4
<b>Thread Size</b>	1/8-28	1/4-19	3/8-19	1/2-14	5/8-14	3/4-14	1-11	1-1/4-11

## Hex Head Plug

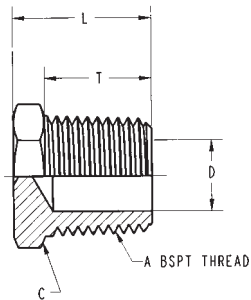
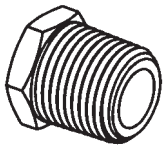

BSPT Pipe Size	Catalog Number	Hex C (mm)	L	T	D Opt. Dia.
1/8	MC3159x2	11	.58	.385	.16
1/4	MC3159x4	14	.76	.577	.25
3/8	MC3159x6	17	.80	.577	.38
1/2	MC3159x8	22	.98	.765	.50
3/4	MC3159x12	27	1.11	.796	.69
1	MC3159x16	36	1.27	.943	.88

## Coupling

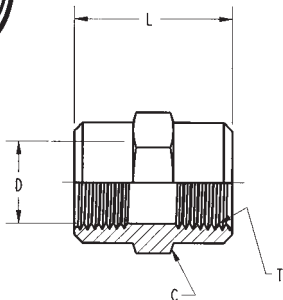
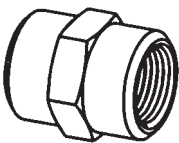

BSPT Pipe Size	Catalog Number	Hex C (mm)	L	D Opt. Dia.
1/8	MC3309x2	17	.75	.337
1/4	MC3309x4	19	1.13	.450
3/8	MC3309x6	22	1.13	.588
1/2	MC3309x8	30	1.50	.733
3/4	MC3309x12	36	1.53	.949
1	MC3309x16	41	1.89	1.192

# BSP Fittings

Steel  
Fittings

## Hex Nipple

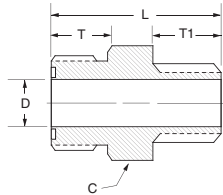
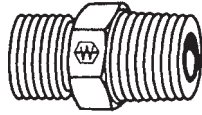

BSPT Pipe Size A	BSPT Pipe Size A1	Catalog Number	Hex C (mm)	L	T	T1	D	D1
1/8	1/8	MC3069x2x2	11	1.06	.395	.395	.188	.188
1/4	1/8	MC3069x4x2	17	1.26	.575	.395	.281	.188
1/4	1/4	MC3069x4x4	17	1.45	.575	.575	.281	.281
3/8	1/4	MC3069x6x4	19	1.45	.575	.575	.406	.281
3/8	3/8	MC3069x6x6	19	1.45	.575	.575	.406	.406
1/2	3/8	MC3069x8x6	22	1.70	.765	.575	.531	.406
1/2	1/2	MC3069x8x8	22	1.89	.765	.765	.531	.531
3/4	1/2	MC3069x12x8	30	1.99	.795	.765	.719	.531
3/4	3/4	MC3069x12x12	30	2.02	.795	.795	.719	.719
1	3/4	MC3069x16x12	36	2.18	.955	.795	.939	.719
1	1	MC3069x16x16	36	2.34	.955	.955	.939	.939
1-1/4	1	MC3069x20x16	46	2.51	1.045	.955	1.252	.939
1-1/4	1-1/4	MC3069x20x20	46	2.60	1.045	1.045	1.252	1.252
1-1/2	1-1/4	MC3069x24x20	50	2.67	1.045	1.045	1.502	1.252
1-1/2	1-1/2	MC3069x24x24	50	2.67	1.045	1.045	1.502	1.502
2	1-1/2	MC3069x32x24	65	2.98	1.205	1.045	1.940	1.502
2	2	MC3069x32x32	65	3.14	1.205	1.205	1.940	1.940

## Male Connector

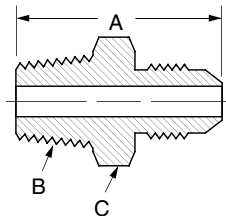
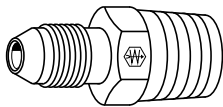

Tube O.D.	BSPT Pipe Size	Catalog Number	BSPT Thread B	A	Hex C	D	D1
1/4	1/8	MC5205x4x2	1/8-28	1.22	1/2	.172	.281
1/4	1/4	MC5205x4x4	1/4-19	1.42	9/16	.172	.188
1/4	3/8	MC5205x4x6	1/4-19	1.42	1/2	.172	.406
5/16	1/4	MC5205x5x4	1/4-19	1.22	9/16	.234	.281
5/16	3/8	MC5205x5x6	3/8-19	1.42	47/64	.234	.406
3/8	1/4	MC5205x6x4	1/4-19	1.21	5/8	.297	.406
3/8	3/8	MC5205x6x6	3/8-19	1.29	3/4	.297	.281
3/8	1/2	MC5205x6x8	1/2-14	1.69	55/64	.297	.531
3/8	3/4	MC5205x6x12	3/4-14	1.78	1-5/32	.297	.719
1/2	3/8	MC5205x8x6	3/8-19	1.41	13/16	.391	.531
1/2	1/2	MC5205x8x8	1/2-14	1.59	15/16	.391	.406
1/2	3/4	MC5205x8x12	3/4-14	1.88	1-5/32	.391	.719
5/8	1/2	MC5205x10x8	1/2-14	1.66	15/16	.484	.531
5/8	3/4	MC5205x10x12	3/4-14	1.99	1-1/8	.484	.719
5/8	1	MC5205x10x16	1-11	2.15	1-13/32	.484	.939
3/4	1/2	MC5205x12x8	1/2-14	2.06	1-5/32	.609	.719
3/4	1	MC5205x12x16	1-11	2.25	1-13/32	.609	.531
7/8	3/4	MC5205x14x12	3/4-14	2.12	1-5/32	.609	.939
7/8	1	MC5205x14x16	1-11	2.28	1-13/32	.719	.719
3/4	3/4	MC5205x12x12	3/4-14	1.93	1-1/8	.719	.942
1	3/4	MC5205x16x12	3/4-14	2.14	1-13/32	.845	.939
1	1	MC5205x16x16	1-11	2.13	1-3/8	.845	.719
1-1/4	1-1/4	MC5205x20x20	1-1/4-11	2.34	1-11/16	1.080	1.252
1-1/2	1-1/2	MC5205x24x24	1-1/2-11	2.71	1-15/16	1.314	1.502
2	2	MC5205x32x32	2-11	3.27	2-3/4	1.784	1.940

STEEL

## Male British Standard Parallel Pipe to Male 37° SAE

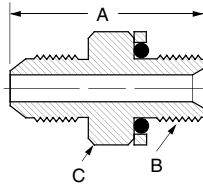
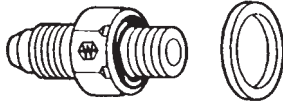

Replacement retaining rings and O-rings page 189.

Tube O.D.	BSP Pipe Size	Catalog Number	BSP Thread B	A	Hex C
1/4	1/8	MB5315x4x2	1/8-28	1.10	5/8
1/4	1/4	MB5315x4x4	1/4-19	1.24	3/4
5/16	1/4	MB5315x5x4	1/4-19	1.24	3/4
3/8	1/4	MB5315x6x4	1/4-19	1.25	3/4
3/8	3/8	MB5315x6x6	3/8-19	1.31	7/8
1/2	3/8	MB5315x8x6	3/8-19	1.48	7/8
1/2	1/2	MB5315x8x8	1/2-14	1.67	1-1/8
5/8	3/4	MB5315x10x12	3/4-14	1.83	1-3/8
3/4	3/4	MB5315x12x12	3/4-14	1.93	1-3/8
1	1	MB5315x16x16	1-11	2.20	1-3/4
1-1/4	1-1/4	MB5315x20x20	1-1/4-11	2.32	2

## Female 37° SAE Swivel to Male British Standard Tapered Pipe Thread

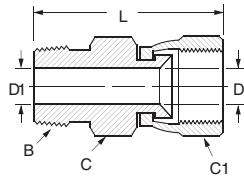
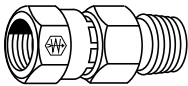

\*Optional counterbore.

Tube O.D.	BSPT Pipe Size	Catalog Number	BSPT Thread B	Hex C	Hex C1	D	D1	L
1/4	1/4	M9800x4x4	1/4-19	9/16	9/16	.172	.281*	1.56
5/16	1/4	M9800x5x4	1/4-19	11/16	5/8	.234	.281*	1.63
3/8	1/4	M9800x6x4	1/4-19	11/16	11/16	.297	.281	1.69
1/2	1/4	M9800x8x4	1/4-19	7/8	7/8	.391	.281	1.87
1/2	3/8	M9800x8x6	3/8-19	7/8	7/8	.391	.406*	1.87
1/2	1/2	M9800x8x8	1/2-14	7/8	7/8	.391	.531*	2.06
5/8	1/2	M9800x10x8	1/2-14	1	1	.484	.531*	2.11
3/4	1/2	M9800x12x8	1/2-14	1-1/8	1-1/4	.609	.531	2.21
3/4	3/4	M9800x12x12	3/4-14	1-1/8	1-1/4	.609	.719*	2.24
1	3/4	M9800x16x12	3/4-14	1-3/8	1-1/2	.845	.719	2.39
1	1	M9800x16x16	1-11	1-3/8	1-1/2	.845	.938*	2.55
1-1/4	1-1/4	M9800x20x20	1-1/4-11	1-7/8	2	1.079	1.125*	2.73

## Female 37° SAE Swivel to Male British Standard Parallel Pipe Thread

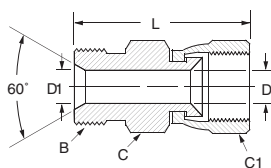
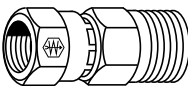

\*Optional counterbore.

Tube O.D.	BSP Pipe Size	Catalog Number	BSP Thread B	Hex C1	Hex C	D	D1	L
1/4	1/4	M9600x4x4	1/4-19	9/16	9/16	.172	.198*	1.43
5/16	1/4	M9600x5x4	1/4-19	5/8	11/16	.234	.198	1.50
3/8	1/4	M9600x6x4	1/4-19	11/16	11/16	.297	.198	1.56
3/8	3/8	M9600x6x6	3/8-19	11/16	11/16	.297	.322*	1.66
1/2	3/8	M9600x8x6	3/8-19	7/8	7/8	.391	.322	1.77
1/2	1/2	M9600x8x8	1/2-14	7/8	7/8	.391	.448*	1.92
5/8	1/2	M9600x10x8	1/2-14	1	1	.484	.448	1.97
3/4	3/4	M9600x12x12	3/4-14	1-1/4	1-1/8	.609	.666*	2.25
1	1	M9600x16x16	1-11	1-1/2	1-3/8	.845	.885*	2.48
1-1/4	1-1/4	M9600x20x20	1-1/4-11	2	1-7/8	1.078	1.125*	2.64

# BSP Fittings

**Steel  
Fittings**

## Male British Standard Tapered Pipe to Male SAE 37° SAE 90° Elbow

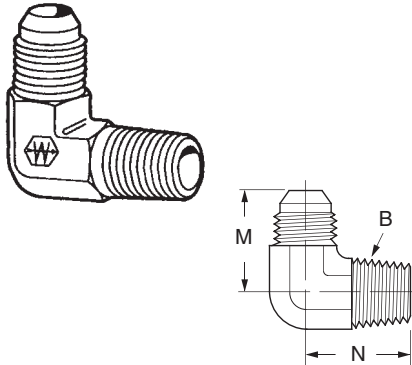

Tube O.D.	BSPT Pipe Size	Catalog Number	BSPT Thread B	M	N	Across Flats
1/4	1/4	<a href="#">MC5405x4x4</a>	1/4-19	1.05	1.09	7/16
5/16	1/4	<a href="#">MC5405x5x4</a>	1/4-19	1.05	1.09	1/2
3/8	1/4	<a href="#">MC5405x6x4</a>	1/4-19	1.06	1.09	9/16
3/8	3/8	<a href="#">MC5405x6x6</a>	3/8-19	1.14	1.22	3/4
1/2	3/8	<a href="#">MC5405x8x6</a>	3/8-19	1.25	1.22	3/4
1/2	1/2	<a href="#">MC5405x8x8</a>	1/2-14	1.33	1.47	7/8
5/8	3/4	<a href="#">MC5405x10x12</a>	3/4-14	1.54	1.59	1-1/16
3/4	3/4	<a href="#">MC5405x12x12</a>	3/4-14	1.66	1.59	1-1/16
1	1	<a href="#">MC5405x16x16</a>	1-11	1.81	1.97	1-5/16
1-1/4	1-1/4	<a href="#">MC5405x20x20</a>	1-1/4-11	2.06	2.38	1-5/8

## Male British Standard Parallel Pipe to Male 37° SAE 90° Elbow

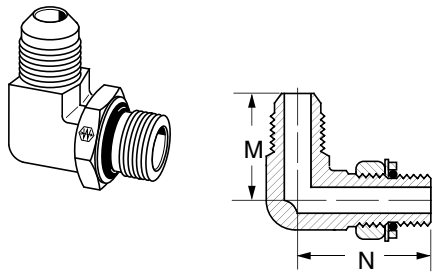

Tube O.D.	BSPP Pipe Size	Catalog Number	BSPP Thread	M	N	Across Flats
1/4	1/4	<a href="#">MB5515x4x4</a>	1/4-19	1.05	1.25	9/16
5/16	1/4	<a href="#">MB5515x5x4</a>	1/4-19	.95	1.25	9/16
3/8	1/4	<a href="#">MB5515x6x4</a>	1/4-19	1.06	1.25	9/16
3/8	3/8	<a href="#">MB5515x6x6</a>	3/8-19	1.14	1.45	3/4
1/2	3/8	<a href="#">MB5515x8x6</a>	3/8-19	1.25	1.45	3/4
1/2	1/2	<a href="#">MB5515x8x8</a>	1/2-14	1.33	1.70	7/8
5/8	3/4	<a href="#">MB5515x10x12</a>	3/4-14	1.34	1.94	1-1/16
3/4	3/4	<a href="#">MB5515x12x12</a>	3/4-14	1.66	1.94	1-1/16
1	1	<a href="#">MB5515x16x16</a>	1-11	1.81	2.05	1-5/16
1-1/4	1-1/4	<a href="#">MB5515x20x20</a>	1-1/4-11	2.06	2.25	1-5/8

Replacement retaining rings and O-rings see below.

## British Retaining Ring

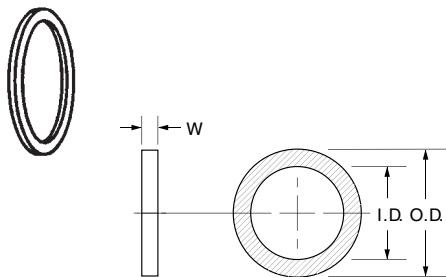

Tube O.D.	Catalog Number	Ring I.D.	Ring O.D.	W
2	<a href="#">MB7630x2</a>	.45	.60	.044
4	<a href="#">MB7630x4</a>	.63	.81	.067
6	<a href="#">MB7630x6</a>	.77	.93	.067
8	<a href="#">MB7630x8</a>	.91	1.12	.067
10	<a href="#">MB7630x10</a>	1.00	1.24	.067
12	<a href="#">MB7630x12</a>	1.12	1.37	.067
16	<a href="#">MB7630x16</a>	1.44	1.74	.092
20	<a href="#">MB7630x20</a>	1.76	2.18	.092
24	<a href="#">MB7630x24</a>	2.02	2.43	.092

## British O-Ring

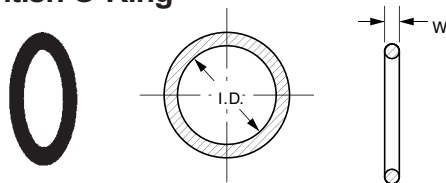

**Material:** Buna N 90 Durometer  
**Temperature Range:** -40°F to +250°F  
 (-40°C to +121°C)

Tube O.D.	Catalog Number	W	I.D.
2	<a href="#">MB7629x2</a>	.070	.239
4	<a href="#">MB7629x4</a>	.103	.424
6	<a href="#">MB7629x6</a>	.103	.549
8	<a href="#">MB7629x8</a>	.103	.695
10	<a href="#">MB7629x10</a>	.103	.818
12	<a href="#">MB7629x12</a>	.103	.924
16	<a href="#">MB7629x16</a>	.139	1.171
20	<a href="#">MB7629x20</a>	.139	1.484

STEEL

⚠ Refer to safety information regarding tubing selection on page 1.

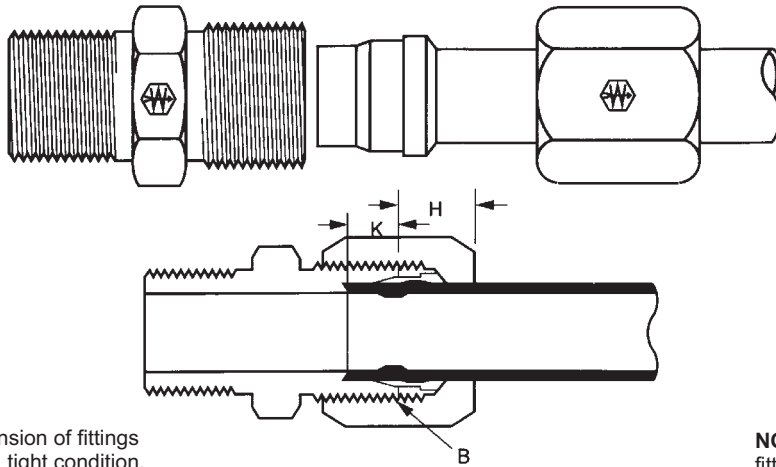

NOTE: "H" is dimension of fittings assembled to hand tight condition.

NOTE: Illustration shows fitting fully assembled.

Tube O.D.	1/8	3/16	1/4	5/16	3/8	1/2	5/8	3/4	7/8	1	1-1/4	1-1/2	2
Thread Size-B	5/16-24	3/8-24	7/16-20	1/2-20	9/16-18	3/4-16	7/8-14	1-1/16-12	1-3/16-12	1-5/16-12	1-5/8-12	1-7/8-12	2-1/2-12
Seat Depth-K	.19	.24	.24	.26	.26	.31	.36	.36	.36	.42	.42	.49	.49
H (Ref.)	.31	.30	.39	.41	.47	.48	.53	.55	.53	.63	.56	.61	.64

**Forged Fittings and Adapters**

**Ermeto® Fittings 7000 Series Pressure Rating Chart**

Connection Type	End Size												
	1/8"	3/16"	1/4"	5/16"	3/8"	1/2"	5/8"	3/4"	7/8"	1"	1-1/4"	1-1/2"	2"
Ermeto® Fittings	5000	5000	5000	5000	5000	4000	4000	4000	4000	4000	3000	3000	3000
W/Adjustable Straight Thread O-Ring	5000	5000	4500	4000	4000	4000	3000	3000	2500	2500	2000	1500	1125
With Male Pipe	5000		5000		5000	4000		4000		4000	3000	2500	2500
With Female Pipe	5000		5000		4000	3000		2500		2000	1500	1500	1000

- Typical Application**  
 Hydraulic, instrumentation and chemical processing systems. Highly recommended for high pressure applications.
- Material**  
**Carbon Steel** - AISI/SAE 12L14  
**Plating** - Weathercote®  
**Stainless Steel** - Bodies and nuts: type 316. Sleeves: 17-4PH.
- Used With**  
 Aluminum, hard or half copper, steel, stainless steel, monel, titanium and extra heavy wall tubing that cannot be flared. See page 28-32 for material compatibility.
- Advantages**  
 An excellent high pressure fitting - NO TUBE FLARING. Used with extra heavy wall tubing. Broad selection of sizes and styles.
- Conformance**  
 Meets specifications and standards of ASA, ASME and SAE.
- How to Order**  
 For complete assembly (body, nut and sleeve) order individually by catalog number. Example: 7205x4. To order body only (less nut and sleeve), prefix the catalog number with the letter "B". Example: B7205x4. Nuts and sleeves can be ordered separately by catalog number.
- NOTE**  
 Refer to current price list for availability of cataloged items. Quotations and delivery of non-stock items supplied on request. Configurations and dimensions subject to change without notice. Additional information can be found in SAE J514.
- Assembly Instructions**  
 See page 191.
- Label Set: FS-1600** (adhesive)
- Pressure**  
 Operating pressure up to 5,000 psi depending on tube and fitting size. See steel fittings recommendations, pages 194.
- Vibration**  
 Excellent resistance.
- Temperature Range**  
 -65°F to +400°F (-53°C to +204°C) at maximum operating pressures. Has been used at 800°F and 1000 psi to 4000 psi depending on tube size. Stainless steel has been used at +1000°F and 2000 psi.



 Refer to safety information regarding tubing selection on page 1.

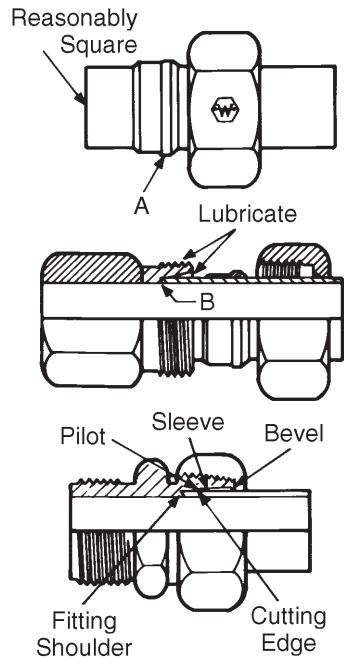

### PRESETTING OPERATION

**Preset with Preset Tool:** (Preset tools are listed on page 223.)

- CAUTION:** All stainless steel sleeves should be preset in tool prior to installation.
- Slide nut and then sleeve on tube. Shoulder of sleeve "A" must be toward nut.
- Insert tube into presetting tool. Be sure that tube is bottomed on fitting tube stop at point "B". Lubricate threads, seat of fitting and shoulder of sleeve with good grade of lubricant.
- Turn nut slowly with wrench while turning tube with other hand. When the sleeve grips the tube, that is, when the tube can no longer be turned by hand – **STOP** – and note the position of the wrench. This is the "Ring Grip" point.
- Tighten nut an additional number of turns past the ring grip point per tube size and wall thickness as shown in Table 1, page 192.
- Disassemble from preset tool.

**Preset in Fitting Body:**

- Follow same procedure as when presetting with preset tool. Once the fitting nut has been turned the proper number of turns past ring grip, the fitting assembly is complete and ready for use.

**NOTE:** Only Carbon Steel Sleeves can be preset directly into the fitting body. Due to possible thread galling, the use of presetting tools is required when stainless steel fittings are to be assembled.

### FITTING INSTALLATION

- After sleeve and nut have been preset on the tubing and checked as described, the assembly is ready for installation into the Ermeto® fitting seat.
- Lubricate threads, seat of fitting and shoulder of sleeve with a good grade of lubricant compatible with system fluid.
- Insert tube assembly into fitting and tighten nut until sharp rise in torque is felt.
- Starting at the position of sharp torque rise, tighten nut 1/4 turn to complete assembly.

**When the assembly procedure for Ermeto fittings is followed correctly, these points will be evident:**

- Cutting edge of sleeve will be imbedded in tubing to its full depth.
- Pilot edge of sleeve should be close to or touching O.D. of tubing.
- Distance between end of tube and leading or pilot edge of sleeve will be at least 1/8".
- Metal will be piled ahead of cutting edge of sleeve under pilot.
- Contact area of sleeve will show evidence of being in perfect contact with tapered seat of fitting.
- Sleeve will show evidence of being bowed within its elastic limits.
- Back of sleeve will be in contact with tube.

**NOTE:** Performance of fitting will not be affected if sleeve rotates on tube after disassembly.

### FOR RE-INSTALLATION OF FITTING AFTER DISASSEMBLING

- Insert tube assembly into fitting, tighten nut until a sharp rise in torque is felt.
- Starting at the position of sharp torque rise, tighten nut 1/4 turn to complete the reinstallation.

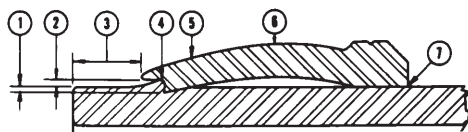

 Refer to safety information regarding tubing selection on page 1.

**7000 SERIES**

**TABLE 1: Number of Additional Turns from “Ring Grip” for Hand Presetting Operation-Ermeto® Sleeve**

Tube Size	Tube Material **	Tube Wall Thickness									
		.018	.022	.028	.035	.049	.065	.083	.095	.109	.120
2	C 1010 MIL T 8504	1-1/6 1-1/6	1-1/6 1-1/6	1-1/6 1-1/6	1-1/6 1-1/6						
3	C 1010 MIL T 8504	1-1/6 1-1/6	1-1/6 1-1/6	1-1/6 1-1/6	1 1						
4	C 1010 MIL T 8504			1-1/6 1-1/6	1-1/6 1	1-1/6 1	1 5/6				
5	C 1010 MIL T 8504			1-1/6 1-1/6	1-1/6 1-1/6	1-1/6 1	1 1				
6	C 1010 MIL T 8504				1-1/6 1-1/6	1-1/6 1	1 5/6	1 5/6			
8	C 1010 MIL T 8504				1-1/6 1-1/6	1-1/6 1	1 5/6	1 5/6	1 5/6		
10	C 1010 MIL T 8504					1-1/6 1-1/6	1 1	5/6 5/6	5/6 5/6	5/6	5/6
12	C 1010 MIL T 8504					1 1-1/6	1 1	5/6 5/6	5/6 5/6	5/6 5/6	
16	C 1010 MIL T 8504					1-1/6 1-1/6	1-1/6 1-1/6	5/6 5/6	5/6 5/6	5/6 5/6	
20	C 1010 MIL T 8504					1-1/6 1	1 1	1 1	1 1	5/6 5/6	5/6 5/6
24	C 1010 MIL T 8504								1	1	1
32	C 1010 MIL T 8504								1	1	1

\*\* C 1010 – Carbon Steel Tubing

\*\* MIL T 8504 – Annealed Stainless Steel

 Refer to safety information regarding tubing selection on page 1.

Ermeto® Fittings (7000 Series) are especially designed for making leak-proof tube connections. This fitting will effectively withstand high pressure, severe vibration and extreme temperature. No special tools are needed for assembly. Simply cut tube square, preset sleeve on tubing and assemble.

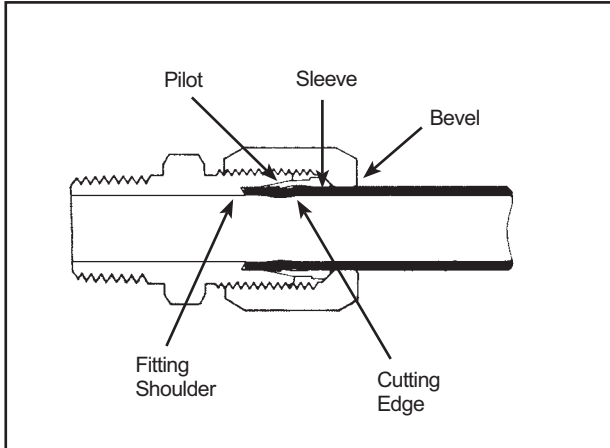

### ERMETO® DESIGN PRINCIPLE PROVIDES POSITIVE SEAL

1. In presetting, as the nut is tightened it forces the sleeve forward into the body taper. See page 191 for preset instructions.
2. Pilot of sleeve contracts, forcing the cutting edge of sleeve to shear a groove into outer surface of the tube, making a tight joint between fitting and tube.
3. In assembling the preset sleeve and tube into the fitting body, the nut presses on the bevel at rear of sleeve causing it to clamp tightly to the tube. Resistance to vibration is concentrated at this point rather than at the sleeve cut.
4. When fully tightened, the case hardened sleeve is bowed slightly at the midsection and acts as a spring. This spring action of the sleeve maintains a constant tension between the body and the nut, and thus prevents the nut from loosening.
5. After the first assembly, the sleeve is permanently attached to the tube. Disassembly and reassembly of the fitting can be made without loss of strength or sealing qualities.

### “7000” SERIES FITTINGS

Specifically designed to meet all SAE approved standards for hydraulic flareless tube fittings. Available in a complete range of standard body styles. In addition, the “7000” Series includes all body styles for SAE straight thread O-ring boss mounting. Complete size range to 2”.

### CARBON STEEL “7000” SERIES

Weatherhead Ermeto® Fittings have the exclusive “Weathercote” finish, which fully resists the effects of non-flammable hydraulic fluids.

### STAINLESS STEEL “7000” SERIES

Fittings also available in a complete range of body styles and sizes.

Standard stainless steel assemblies may be ordered by quoting the stainless steel part numbers appearing in this catalog. Standard stainless steel assemblies are composed of the following types of material:

BODY – Type 316 Stainless Steel

NUT – Type 316 Stainless Steel

SLEEVE – Type 17-4PH Stainless Steel

Any deviation from the standard assembly must be ordered as component parts. Example: If Type 316 bodies and 17-4PH sleeves are to be used, they can be ordered as follows:

B7217x8 Body only (Type 316 Stainless Steel)

7176x8 Sleeves (Type 17-4PH Stainless Steel)

7105x8 Nuts (Standard Carbon Steel)

In general, the “bite-action” of the sleeves in any given material varies as shown in the following table:

### STAINLESS STEEL SLEEVES

Cat. No. 7176 sleeves are made from Armco 17-4PH precipitation hardened stainless steel. When used on “fully-annealed” to 1/8 hard tubing in the 303 to 316 stainless range, they provide the typical seal.

“7000” Series Sleeve	SLEEVE MATERIAL	TUBING USED 303 to 316 Stainless and Cupro-Nickel	“BITE-ACTION”
7165	Heat Treated Carbon Steel (Standard Carbon)	Fully annealed to 1/8 hard	Excellent
7176	17-4PH Stainless (Standard Stainless)	Fully annealed	Excellent

When stainless steel tubing is used for strength and no corrosive conditions exist, use the 7165 sleeve for better performance.

**HYDRAULIC PRESSURE DATA – ERMETO® FLARELESS FITTINGS**

Ermeto® fittings have been used with success on many and varied applications far exceeding the conservative conditions presented below. Specifically:

- Temperatures up to 800°F, in carbon steel and 1000°F, in stainless steel have been handled without failure.\*
- Burst pressures up to 32,000 psi with 1/4" tubing.
- Vibration conditions of 1/8" off-center amplitude with 12" overhang in 1/4" tubing have been withstood at rated operating pressure with 4-to-1 safety factors for over ten million cycles.

Obviously under extreme conditions of pressure, temperature and/or vibration, the safety factor is proportionately reduced.

The Ermeto® flareless fitting is the ultimate hydraulic fitting available today. Special performance conditions as outlined can be accommodated; however, it is recommended that your local Weatherhead representative be consulted for engineering assistance prior to finalizing design.

The values shown in the following table are pressure ratings of Ermeto® flareless fittings under various surge conditions. They apply and are recommended for conservative operating conditions. Consult tubing selection charts on pages 22 and 23.

Size No.	Size in Inches	Maximum Pressure† No Surges PSI	Maximum Pressure† With Surges to 50%	Maximum Pressure† With Surges of 50% to 100%	Maximum Pressure† With Surges up to 150%
2	1/8	10,000	6,500	5,000	4,000
3	3/16	9,000	6,000	4,500	3,600
4	1/4	8,000	5,250	4,000	3,200
5	5/16	8,000	5,250	4,000	3,200
6	3/8	7,500	5,000	3,750	3,000
8	1/2	7,000	4,500	3,500	2,700
10	5/8	5,000	3,250	2,500	2,000
12	3/4	5,000	3,250	2,500	2,000
14	7/8	3,750	2,500	1,800	1,500
16	1	3,600	2,400	1,800	1,400
20	1-1/4	3,200	2,100	1,600	1,275
24	1-1/2	3,000	2,000	1,500	1,200
32	2	2,750	1,800	1,350	1,100

† Pressures shown do not apply to pneumatic applications or stainless steel tubing installations.

\* Zinc plating discolors at temperatures over 400°F and melts at 750°F.

### Straight Thread O-Ring Thread Sizes

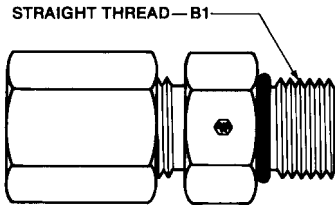

Port Size	Thread Size B1	Port Size	Thread Size B1
1/8	5/16-24	3/4	1-1/16-12
3/16	3/8-24	7/8	1-3/16-12
1/4	7/16-20	1	1-5/16-12
5/16	1/2-20	1-1/4	1-5/8-12
3/8	9/16-18	1-1/2	1-7/8-12
1/2	3/4-16	2	2-1/2-12
5/8	7/8-14		

### 7000 Series Reducer

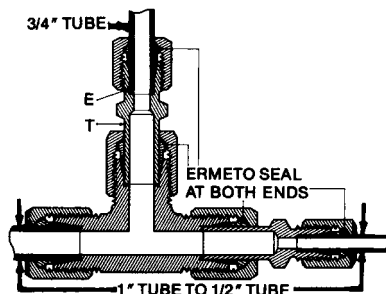

#### Enables You to Fabricate Special Fittings from Standard Parts

The Weatherhead reducer consists of body, nut and sleeve. It has one end (T) machined in the form of a tube with a flareless tube connection on the opposite end (E). A convenient hex wrench pad is provided to facilitate assembly.

1. Connect the tube end (T) of the reducer to the flareless fitting already assembled in the tubing system.
2. Connect the smaller O.D. tubing to end (E).

**CAUTION:** Be sure to hold reducer by the hex wrench pad while performing Step 2.

Our example of 7705x12x6x8 is made up by using reducers 7015x12x6 and 7015x12x8 with the standard 7705x12 tee.

### Straight Thread O-Ring Fitting

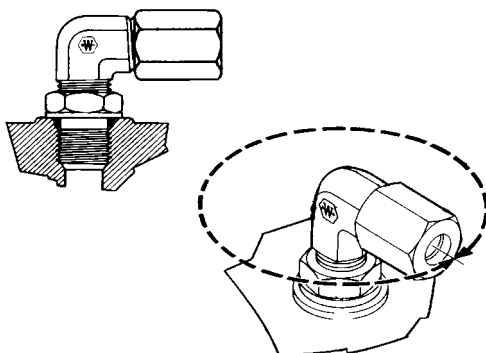

#### Adjustable Fittings

- Permit exact positioning of tees and elbows.
  - Provide a leakproof joint.
  - Eliminate distorted bosses from overtightening.
1. Lubricate O-ring by coating with a light oil or petrolatum and push back-up washer and O-ring to the extreme rear of the O-ring groove.
  2. Turn the lock nut down until it just contacts the back-up washer.
  3. Screw fitting by hand into straight thread boss until the back-up washer contacts the face of the boss.
  4. Position the fitting by backing out (counter-clockwise) up to one full turn. Hold fitting in desired position and tighten lock nut with a wrench.
  5. Assemble tube to fitting. Re-tighten lock nut.

**NOTE:** O-Rings, lock nuts and back-up washers are preassembled on all straight thread fittings.

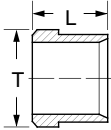
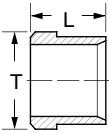
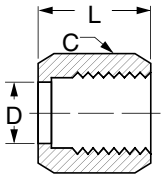
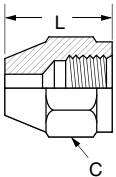
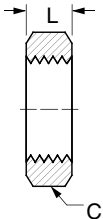
<p><b>Sleeve</b> Stainless Steel No. <b>7176x</b> (Ref. SAE No. 080115B)</p>		<table border="1"> <thead> <tr> <th>Tube O.D.</th> <th>Catalog Number</th> <th>L</th> <th>Dia. T</th> </tr> </thead> <tbody> <tr><td>1/8</td><td>7165x2</td><td>.28</td><td>.20</td></tr> <tr><td>3/16</td><td>7165x3</td><td>.28</td><td>.31</td></tr> <tr><td>1/4</td><td>7165x4</td><td>.34</td><td>.36</td></tr> <tr><td>5/16</td><td>7165x5</td><td>.34</td><td>.42</td></tr> <tr><td>3/8</td><td>7165x6</td><td>.38</td><td>.48</td></tr> <tr><td>1/2</td><td>7165x8</td><td>.38</td><td>.63</td></tr> <tr><td>5/8</td><td>7165x10</td><td>.42</td><td>.75</td></tr> <tr><td>3/4</td><td>7165x12</td><td>.42</td><td>.88</td></tr> <tr><td>7/8</td><td>7165x14</td><td>.42</td><td>1.00</td></tr> <tr><td>1</td><td>7165x16</td><td>.42</td><td>1.13</td></tr> <tr><td>1-1/4</td><td>7165x20</td><td>.42</td><td>1.41</td></tr> <tr><td>1-1/2</td><td>7165x24</td><td>.42</td><td>1.66</td></tr> <tr><td>2</td><td>7165x32</td><td>.45</td><td>2.19</td></tr> </tbody> </table>	Tube O.D.	Catalog Number	L	Dia. T	1/8	7165x2	.28	.20	3/16	7165x3	.28	.31	1/4	7165x4	.34	.36	5/16	7165x5	.34	.42	3/8	7165x6	.38	.48	1/2	7165x8	.38	.63	5/8	7165x10	.42	.75	3/4	7165x12	.42	.88	7/8	7165x14	.42	1.00	1	7165x16	.42	1.13	1-1/4	7165x20	.42	1.41	1-1/2	7165x24	.42	1.66	2	7165x32	.45	2.19														
Tube O.D.	Catalog Number	L	Dia. T																																																																					
1/8	7165x2	.28	.20																																																																					
3/16	7165x3	.28	.31																																																																					
1/4	7165x4	.34	.36																																																																					
5/16	7165x5	.34	.42																																																																					
3/8	7165x6	.38	.48																																																																					
1/2	7165x8	.38	.63																																																																					
5/8	7165x10	.42	.75																																																																					
3/4	7165x12	.42	.88																																																																					
7/8	7165x14	.42	1.00																																																																					
1	7165x16	.42	1.13																																																																					
1-1/4	7165x20	.42	1.41																																																																					
1-1/2	7165x24	.42	1.66																																																																					
2	7165x32	.45	2.19																																																																					
<p><b>Sleeve</b>  For use with diesel nuts only.</p>		<table border="1"> <thead> <tr> <th>Tube O.D.</th> <th>Catalog Number</th> <th>L</th> <th>Dia. T</th> </tr> </thead> <tbody> <tr><td>1/4</td><td>8165x4</td><td>.34</td><td>.38</td></tr> <tr><td>5/16</td><td>8165x5</td><td>.34</td><td>.44</td></tr> <tr><td>3/8</td><td>8165x6</td><td>.38</td><td>.50</td></tr> </tbody> </table>	Tube O.D.	Catalog Number	L	Dia. T	1/4	8165x4	.34	.38	5/16	8165x5	.34	.44	3/8	8165x6	.38	.50																																																						
Tube O.D.	Catalog Number	L	Dia. T																																																																					
1/4	8165x4	.34	.38																																																																					
5/16	8165x5	.34	.44																																																																					
3/8	8165x6	.38	.50																																																																					
<p><b>Nut</b> Stainless Steel No. <b>7117x</b> (Ref. SAE No. 080110)</p>		<table border="1"> <thead> <tr> <th>Tube O.D.</th> <th>Catalog Number</th> <th>Hex C</th> <th>L</th> <th>D Dia.</th> </tr> </thead> <tbody> <tr><td>1/8</td><td>7105x2</td><td>3/8</td><td>.53</td><td>.132</td></tr> <tr><td>3/16</td><td>7105x3</td><td>7/16</td><td>.61</td><td>.195</td></tr> <tr><td>1/4</td><td>7105x4</td><td>9/16</td><td>.70</td><td>.257</td></tr> <tr><td>5/16</td><td>7105x5</td><td>5/8</td><td>.72</td><td>.320</td></tr> <tr><td>3/8</td><td>7105x6</td><td>11/16</td><td>.75</td><td>.382</td></tr> <tr><td>1/2</td><td>7105x8</td><td>7/8</td><td>.84</td><td>.508</td></tr> <tr><td>5/8</td><td>7105x10</td><td>1</td><td>.92</td><td>.634</td></tr> <tr><td>3/4</td><td>7105x12</td><td>1-1/4</td><td>.97</td><td>.759</td></tr> <tr><td>7/8</td><td>7105x14</td><td>1-3/8</td><td>1.00</td><td>.884</td></tr> <tr><td>1</td><td>7105x16</td><td>1-1/2</td><td>1.05</td><td>1.009</td></tr> <tr><td>1-1/4</td><td>7105x20</td><td>2</td><td>1.05</td><td>1.263</td></tr> <tr><td>1-1/2</td><td>7105x24</td><td>2-1/4</td><td>1.03</td><td>1.513</td></tr> <tr><td>2</td><td>7105x32</td><td>2-7/8</td><td>1.12</td><td>2.017</td></tr> </tbody> </table>	Tube O.D.	Catalog Number	Hex C	L	D Dia.	1/8	7105x2	3/8	.53	.132	3/16	7105x3	7/16	.61	.195	1/4	7105x4	9/16	.70	.257	5/16	7105x5	5/8	.72	.320	3/8	7105x6	11/16	.75	.382	1/2	7105x8	7/8	.84	.508	5/8	7105x10	1	.92	.634	3/4	7105x12	1-1/4	.97	.759	7/8	7105x14	1-3/8	1.00	.884	1	7105x16	1-1/2	1.05	1.009	1-1/4	7105x20	2	1.05	1.263	1-1/2	7105x24	2-1/4	1.03	1.513	2	7105x32	2-7/8	1.12	2.017
Tube O.D.	Catalog Number	Hex C	L	D Dia.																																																																				
1/8	7105x2	3/8	.53	.132																																																																				
3/16	7105x3	7/16	.61	.195																																																																				
1/4	7105x4	9/16	.70	.257																																																																				
5/16	7105x5	5/8	.72	.320																																																																				
3/8	7105x6	11/16	.75	.382																																																																				
1/2	7105x8	7/8	.84	.508																																																																				
5/8	7105x10	1	.92	.634																																																																				
3/4	7105x12	1-1/4	.97	.759																																																																				
7/8	7105x14	1-3/8	1.00	.884																																																																				
1	7105x16	1-1/2	1.05	1.009																																																																				
1-1/4	7105x20	2	1.05	1.263																																																																				
1-1/2	7105x24	2-1/4	1.03	1.513																																																																				
2	7105x32	2-7/8	1.12	2.017																																																																				
<p><b>Diesel Nut</b></p>		<table border="1"> <thead> <tr> <th>Tube O.D.</th> <th>Thread Size</th> <th>Catalog Number</th> <th>Hex C</th> <th>L</th> </tr> </thead> <tbody> <tr><td>1/4</td><td>9/16-18</td><td>8112x4</td><td>3/4</td><td>.94</td></tr> <tr><td>5/16</td><td>5/8-18</td><td>8112x5</td><td>13/16</td><td>1.00</td></tr> <tr><td>3/8</td><td>3/4-16</td><td>8112x6</td><td>15/16</td><td>1.13</td></tr> </tbody> </table>	Tube O.D.	Thread Size	Catalog Number	Hex C	L	1/4	9/16-18	8112x4	3/4	.94	5/16	5/8-18	8112x5	13/16	1.00	3/8	3/4-16	8112x6	15/16	1.13																																																		
Tube O.D.	Thread Size	Catalog Number	Hex C	L																																																																				
1/4	9/16-18	8112x4	3/4	.94																																																																				
5/16	5/8-18	8112x5	13/16	1.00																																																																				
3/8	3/4-16	8112x6	15/16	1.13																																																																				
<p><b>Bulkhead Nut</b> Stainless Steel No. <b>7936x</b> (Ref. SAE No. 080118)</p>		<table border="1"> <thead> <tr> <th>Tube O.D.</th> <th>Catalog Number</th> <th>Hex C</th> <th>L</th> </tr> </thead> <tbody> <tr><td>1/4</td><td>7924x4</td><td>11/16</td><td>.28</td></tr> <tr><td>3/8</td><td>7924x6</td><td>13/16</td><td>.27</td></tr> <tr><td>1/2</td><td>7924x8</td><td>1</td><td>.31</td></tr> <tr><td>5/8</td><td>7924x10</td><td>1-1/8</td><td>.36</td></tr> <tr><td>3/4</td><td>7924x12</td><td>1-3/8</td><td>.41</td></tr> <tr><td>7/8</td><td>7924x14</td><td>1-1/2</td><td>.41</td></tr> <tr><td>1</td><td>7924x16</td><td>1-5/8</td><td>.41</td></tr> <tr><td>1-1/4</td><td>7924x20</td><td>1-7/8</td><td>.41</td></tr> </tbody> </table>	Tube O.D.	Catalog Number	Hex C	L	1/4	7924x4	11/16	.28	3/8	7924x6	13/16	.27	1/2	7924x8	1	.31	5/8	7924x10	1-1/8	.36	3/4	7924x12	1-3/8	.41	7/8	7924x14	1-1/2	.41	1	7924x16	1-5/8	.41	1-1/4	7924x20	1-7/8	.41																																		
Tube O.D.	Catalog Number	Hex C	L																																																																					
1/4	7924x4	11/16	.28																																																																					
3/8	7924x6	13/16	.27																																																																					
1/2	7924x8	1	.31																																																																					
5/8	7924x10	1-1/8	.36																																																																					
3/4	7924x12	1-3/8	.41																																																																					
7/8	7924x14	1-1/2	.41																																																																					
1	7924x16	1-5/8	.41																																																																					
1-1/4	7924x20	1-7/8	.41																																																																					

### Cap Stainless Steel No. 7141x



Tube O.D.	Catalog Number	Hex C	L
1/2	7129x2	3/8	.53
1/4	7129x4	9/16	.70
3/8	7129x6	11/16	.75
1/2	7129x8	7/8	.84
5/8	7129x10	1	.92
3/4	7129x12	1-1/4	.97
1	7129x16	1-1/2	1.05
1-1/4	7129x20	2	1.05

### Plug Stainless Steel No. 7241x (Ref. SAE No. 080109)



Tube O.D.	Catalog Number	Hex C	L
1/8	7229x2	7/16	.63
1/4	7229x4	1/2	.71
5/16	7229x5	9/16	.71
3/8	7229x6	5/8	.75
1/2	7229x8	13/16	.85
5/8	7229x10	15/16	.97
3/4	7229x12	1-1/8	1.10
1	7229x16	1-3/8	1.10

### Reducer Stainless Steel No. 7027x (Ref. SAE No. 080123)

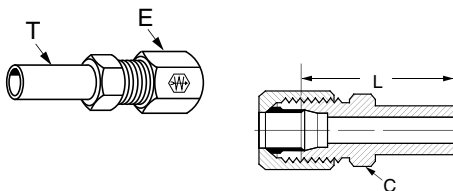

Body Size E	Tube Size T	Catalog Number	Hex C	L
3/8	1/4	7015x6x4	1/2	1.61
1/2	1/4	7015x8x4	9/16	1.73
1/2	3/8	7015x8x6	5/8	1.77
5/8	1/2	7015x10x8	13/16	1.96
3/4	3/8	7015x12x6	13/16	1.93
3/4	1/2	7015x12x8	13/16	2.03
1	3/4	7015x16x12	1-1/8	2.24
1-1/4	1	7015x20x16	1-3/8	2.28

### Small Hex Union Stainless Steel No. 7317x (Ref. SAE No. 080101)

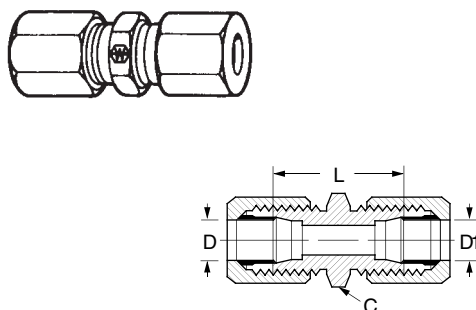

Tube O.D.	Tube O.D.	Catalog Number	Hex C	D	D1	L
1/8	1/8	7305x2	7/16	.093	.093	1.02
3/16	3/16	7305x3	7/16	.125	.125	1.11
1/4	1/4	7305x4	1/2	.203	.203	1.18
5/16	5/16	7305x5	9/16	.234	.234	1.18
3/8	1/4	7305x6x4	5/8	.281	.203	1.22
3/8	3/8	7305x6	5/8	.281	.281	1.24
1/2	3/8	7305x8x6	13/16	.422	.281	1.33
1/2	1/2	7305x8	13/16	.422	.422	1.42
5/8	5/8	7305x10	15/16	.500	.500	1.61
3/4	3/4	7305x12	1-1/8	.656	.656	1.81
7/8	7/8	7305x14	1-1/4	.718	.718	1.81
1	1	7305x16	1-3/8	.875	.875	1.81
1-1/4	1-1/4	7305x20	1-11/16	1.093	1.093	1.89
1-1/2	1-1/2	7305x24	2	1.344	1.344	1.96
2	2	7305x32	2-5/8	1.813	1.813	2.11

### Large Hex Union Stainless Steel No. 7318x (Ref. SAE No. 080119)

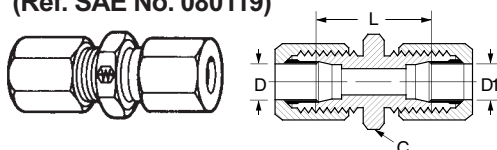

Tube O.D.	Tube O.D.	Catalog Number	Hex C	D	D1	L
1/4	1/4	7306x4	11/16	.203	.203	1.18
3/8	3/8	7306x6	13/16	.281	.281	1.24
1/2	3/8	7306x8x6	1	.422	.281	1.33
1/2	1/2	7306x8	1	.422	.422	1.42
3/4	3/4	7306x12	1-3/8	.656	.656	1.81
1	1	7306x16	1-5/8	.875	.875	1.81

STEEL

**Bulkhead Union**  
Stainless Steel No. **7337x**  
(Ref. SAE No. 080601)

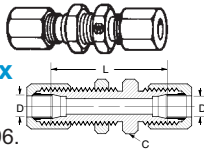

For bulkhead nuts see page 196.

Tube O.D.	Catalog Number	Hex C	D	L
1/4	7325x4	11/16	.203	1.89
3/8	7325x6	13/16	.281	1.98
1/2	7325x8	1	.422	2.22
3/4	7325x12	1-3/8	.656	2.72
1	7325x16	1-5/8	.875	2.72

**Male Connector**  
Stainless Steel No. **7217x**  
(Ref. SAE No. 080102)

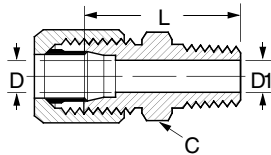
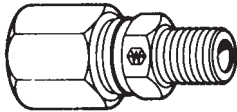

Tube O.D.	Male Pipe Thread	Catalog Number	Hex C	D	D1 Opt.	L
1/8	1/8	7205x2	7/16	.093	.188	1.04
1/8	1/4	7205x2x4	9/16	.093	.281	1.25
3/16	1/8	7205x3	7/16	.125	.188	1.09
1/4	1/8	7205x4	1/2	.203	.188	1.12
1/4	1/4	7205x4x4	9/16	.203	.281	1.32
1/4	3/8	7205x4x6	3/4	.203	.406	1.33
1/4	1/2	7205x4x8	7/8	.203	.531	1.58
5/16	1/8	7205x5	9/16	.234	.188	1.12
5/16	1/4	7205x5x4	9/16	.234	.281	1.32
3/8	1/8	7205x6x2	5/8	.281	.188	1.15
3/8	1/4	7205x6	5/8	.281	.281	1.34
3/8	3/8	7205x6x6	3/4	.281	.406	1.35
3/8	1/2	7205x6x8	7/8	.281	.531	1.60
1/2	1/4	7205x8x4	13/16	.422	.281	1.44
1/2	3/8	7205x8	13/16	.422	.406	1.44
1/2	1/2	7205x8x8	7/8	.422	.531	1.69
1/2	3/4	7205x8x12	1-1/8	.422	.719	1.76
5/8	3/8	7205x10x6	15/16	.500	.406	1.56
5/8	1/2	7205x10	15/16	.500	.531	1.75
3/4	1/2	7205x12x8	1-1/8	.656	.531	1.88
3/4	3/4	7205x12	1-1/8	.656	.719	1.88
7/8	3/4	7205x14	1-1/4	.718	.719	1.88
1	3/4	7205x16x12	1-3/8	.875	.719	1.88
1	1	7205x16	1-3/8	.875	.938	2.07
1-1/4	1-1/4	7205x20	1-11/16	1.093	1.250	2.18
1-1/2	1-1/2	7205x24	2	1.344	1.500	2.28
2	2	7205x32	2-5/8	1.813	1.938	2.46

**Female Connector**  
Stainless Steel No. **7267x**  
(Ref. SAE No. 080103)

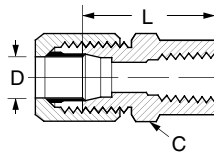
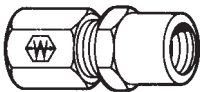

Tube O.D.	Fem. Pipe Thread	Catalog Number	Hex C	D	L
1/8	1/8	7255x2	9/16	.093	1.05
3/16	1/8	7255x3	9/16	.125	1.08
1/4	1/8	7255x4	9/16	.203	1.09
1/4	1/4	7255x4x4	3/4	.203	1.20
5/16	1/8	7255x5	9/16	.234	1.08
3/8	1/4	7255x6	3/4	.281	1.31
3/8	3/8	7255x6x6	7/8	.281	1.40
1/2	1/4	7255x8x4	7/8	.422	1.38
1/2	3/8	7255x8	7/8	.422	1.47
1/2	1/2	7255x8x8	1-1/8	.422	1.63
5/8	1/2	7255x10	1-1/8	.500	1.76
3/4	3/4	7255x12	1-3/8	.656	1.89
7/8	3/4	7255x14	1-3/8	.718	1.86
1	1	7255x16	1-5/8	.875	2.13
1-1/4	1-1/4	7255x20	2	1.093	2.22

**Straight Thread O-Ring Connector**  
Stainless Steel No. **7327x**  
(Ref. SAE No. 080120)

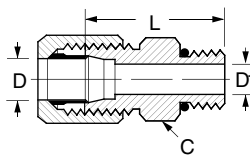
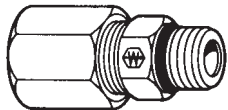

Tube O.D.	Port Size	Catalog Number	Hex C	D	L	D1 Opt.
3/16	3/16	7315x3	1/2	.125	1.04	—
1/4	1/4	7315x4	9/16	.203	1.13	—
1/4	5/16	7315x4x5	5/8	.203	1.13	—
1/4	3/8	7315x4x6	11/16	.203	1.19	.281
5/16	5/16	7315x5	5/8	.234	1.13	—
3/8	3/8	7315x6	11/16	.281	1.21	—
3/8	1/2	7315x6x8	7/8	.281	1.29	.422
1/2	1/2	7315x8	7/8	.422	1.38	—
1/2	5/8	7315x8x10	1	.422	1.51	.500
1/2	3/4	7315x8x12	1-1/4	.422	1.67	.656
5/8	5/8	7315x10	1	.500	1.57	—
3/4	3/4	7315x12	1-1/4	.656	1.79	—
3/4	1	7315x12x16	1-1/2	.656	1.82	.876
7/8	7/8	7315x14	1-3/8	.718	1.79	—
1	3/4	7315x16x12	1-1/2	.875	1.82	.656
1	1	7315x16	1-1/2	.875	1.82	—
1-1/4	1-1/4	7315x20	1-7/8	1.093	1.90	—
1-1/2	1-1/2	7315x24	2-1/8	1.344	1.97	—
2	2	7315x32	2-3/4	1.813	2.13	—

Replacement O-rings page 202.



# Flareless – 7000 Series Ermeto®

**Steel Fittings**

## For-Seal® Male to Ermeto® Connector

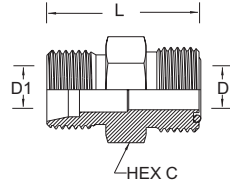
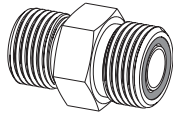

Ermeto® Tube O.D.	For-Seal® Tube O.D.	Catalog Number	Hex C	D	D1	L
1/4	1/4	4307x4	5/8	.172	.203	1.15
3/8	3/8	4307x6	3/4	.264	.281	1.31
1/2	1/2	4307x8	7/8	.378	.422	1.45
5/8	5/8	4307x10	1-1/16	.484	.500	1.70
3/4	3/4	4307x12	1-1/4	.609	.656	1.88
1	1	4307x16	1-1/2	.811	.875	1.94
1-1/4	1-1/4	4307x20	1-3/4	1.024	1.093	2.02
1-1/2	1-1/2	4307x24	2-1/8	1.260	1.344	2.09

## 45° Male Elbow Stainless Steel No. 7367x (Ref. SAE No. 080302)

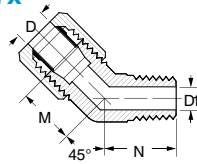
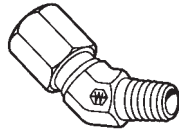

Tube O.D.	Male Pipe Thread	Catalog Number	D	D1	M	N	Across Flats
1/4	1/8	7355x4	.203	.188	.70	.64	7/16
1/4	1/4	7355x4x4	.203	.281	.83	.86	9/16
5/16	1/8	7355x5	.234	.188	.75	.64	9/16
3/8	1/4	7355x6	.281	.281	.83	.86	9/16
1/2	3/8	7355x8	.422	.406	.98	.95	3/4
5/8	1/2	7355x10	.500	.531	1.08	1.17	7/8
3/4	3/4	7355x12	.656	.719	1.27	1.20	1-1/16
1	1	7355x16	.875	.938	1.36	1.48	1-5/16

## 90° Union Elbow Stainless Steel No. 7517x (Ref. SAE No. 080201)

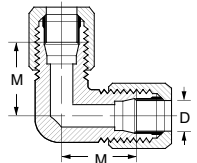
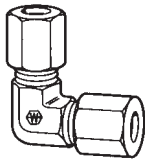

Tube O.D.	Catalog Number	D	M	Across Flats
1/4	7505x4	.203	.89	7/16
5/16	7505x5	.234	.95	1/2
3/8	7505x6	.281	1.05	9/16
1/2	7505x8	.422	1.25	3/4
5/8	7505x10	.500	1.42	7/8
3/4	7505x12	.656	1.58	1-1/16
7/8	7505x14	.718	1.66	1-5/16
1	7505x16	.875	1.73	1-5/16
1-1/4	7505x20	1.093	1.89	1-5/8
1-1/2	7505x24	1.346	2.02	1-7/8

## 90° Male Elbow Stainless Steel No. 7417x (Ref. SAE No. 080202)

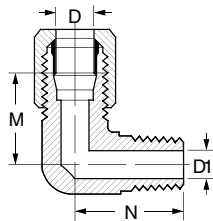
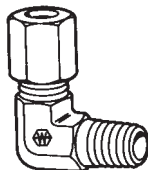

Tube O.D.	Male Pipe Thread	Catalog Number	D	D1	M	N	Across Flats
1/8	1/8	7405x2	.093	.188	.77	.72	7/16
3/16	1/8	7405x3	.125	.188	.83	.72	7/16
1/4	1/8	7405x4	.203	.188	.89	.78	7/16
1/4	1/4	7405x4x4	.203	.281	1.03	1.09	9/16
5/16	1/8	7405x5	.234	.188	.95	.81	1/2
5/16	1/4	7405x5x4	.234	.281	1.03	1.09	9/16
3/8	1/8	7405x6x2	.281	.188	1.05	.90	9/16
3/8	1/4	7405x6	.281	.281	1.05	1.09	9/16
3/8	3/8	7405x6x6	.281	.406	1.16	1.22	3/4
3/8	1/2	7405x6x8	.281	.531	1.24	1.47	7/8
1/2	1/4	7405x8x4	.422	.281	1.25	1.22	3/4
1/2	3/8	7405x8	.422	.406	1.25	1.22	3/4
1/2	1/2	7405x8x8	.422	.531	1.35	1.47	7/8
5/8	3/8	7405x10x6	.500	.406	1.42	1.28	7/8
5/8	1/2	7405x10	.500	.531	1.42	1.47	7/8
3/4	1/2	7405x12x8	.656	.531	1.58	1.59	1-1/16
3/4	3/4	7405x12	.656	.719	1.58	1.59	1-1/16
7/8	3/4	7405x14	.718	.719	1.62	1.69	1-5/16
1	3/4	7405x16x12	.875	.719	1.73	1.78	1-5/16
1	1	7405x16	.875	.938	1.73	1.97	1-5/16
1-1/4	1-1/4	7405x20	1.093	1.250	1.89	2.38	1-5/8
1-1/2	1-1/2	7405x24	1.344	1.500	2.02	2.64	1-7/8
2	2	7405x32	1.813	1.938	2.45	3.00	2-9/16

## 90° Female Elbow Stainless Steel No. 7467x (Ref. SAE No. 080203)

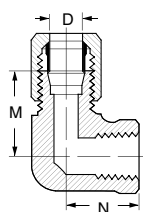
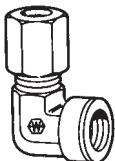

Tube O.D.	Fem. Pipe Thread	Catalog Number	D	M	N	Across Flats
1/4	1/8	7455x4	.203	.89	.66	9/16
1/4	1/4	7455x4x4	.203	1.03	.88	3/4
3/8	1/4	7455x6	.281	1.05	.88	3/4
3/8	3/8	7455x6x6	.281	1.14	1.02	7/8
1/2	3/8	7455x8	.422	1.23	1.02	7/8
1/2	1/2	7455x8x8	.422	1.35	1.23	1-1/16
5/8	1/2	7455x10	.500	1.42	1.23	1-1/16
3/4	3/4	7455x12	.656	1.58	1.36	1-5/16
7/8	3/4	7455x14	.718	1.66	1.42	1-5/16
1	1	7455x16	.875	1.73	1.62	1-5/8

STEEL

**Straight Thread O-Ring 90° Elbow**

**Stainless Steel No. 7527x**  
(Ref. SAE No. 080220)

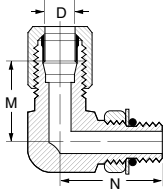
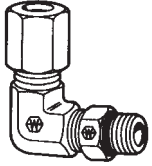

Replacement O-rings page 202.

Tube O.D.	Port Size	Catalog Number	D	M	N	Across Flats
1/4	1/4	7515x4	.203	.89	1.03	7/16
5/16	5/16	7515x5	.234	.96	1.13	9/16
3/8	3/8	7515x6	.281	1.05	1.25	9/16
1/2	1/2	7515x8	.422	1.25	1.45	3/4
5/8	5/8	7515x10	.500	1.42	1.70	7/8
3/4	3/4	7515x12	.656	1.58	1.94	1-1/16
1	1	7515x16	.875	1.73	2.05	1-5/16
1	3/4	7515x16x12	.875	1.73	2.05	1-5/16
1-1/4	1-1/4	7515x20	1.093	1.89	2.25	1-5/8

**Union Tee**

**Stainless Steel No. 7717x**  
(Ref. SAE No. 080401)

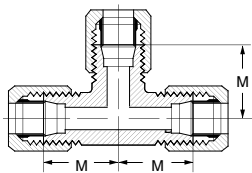
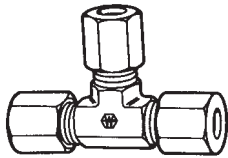

Tube O.D.	Catalog Number	D	M	Across Flats
3/16	7705x3	.125	.83	7/16
1/4	7705x4	.203	.89	7/16
5/16	7705x5	.234	.95	9/16
3/8	7705x6	.281	1.05	9/16
1/2	7705x8	.422	1.25	3/4
5/8	7705x10	.500	1.42	7/8
3/4	7705x12	.656	1.58	1-1/16
7/8	7705x14	.718	1.62	1-5/16
1	7705x16	.875	1.73	1-5/16

**Male Run Tee**

**Stainless Steel No. 7767x**  
(Ref. SAE No. 080424)

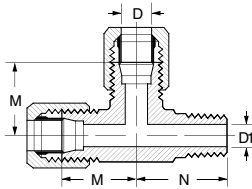
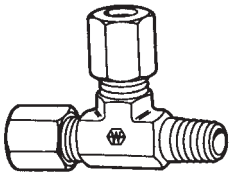

Tube O.D.	Male Pipe Thread	Catalog Number	D	D1	M	N	Across Flats
1/4	1/8	7755x4	.203	.188	.89	.78	7/16
1/4	1/4	7755x4x4x4	.203	.281	1.03	1.09	9/16
3/8	1/4	7755x6	.281	.281	1.05	1.09	9/16
1/2	3/8	7755x8	.422	.422	1.25	1.22	3/4
1/2	1/2	7755x8x8x8	.422	.531	1.35	1.47	7/8
5/8	1/2	7755x10	.500	.531	1.42	1.47	7/8
3/4	3/4	7755x12	.656	.719	1.58	1.59	1-1/16
1	1	7755x16	.875	.938	1.73	1.97	1-5/16

**Female Run Tee**

(Ref. SAE No. 080426)

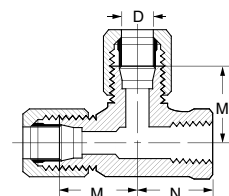
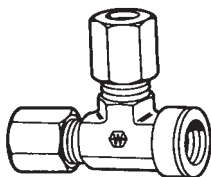

Tube O.D.	Fem. Pipe Thread	Catalog Number	D	M	N	Across Flats
1/4	1/8	7805x4	.203	.89	.66	9/16
1/4	1/4	7805x4x4x4	.203	1.03	.88	3/4
3/8	1/4	7805x6	.281	1.05	.88	3/4
1/2	3/8	7805x8	.422	1.23	1.02	7/8
5/8	1/2	7805x10	.500	1.42	1.23	1-1/16
3/4	3/4	7805x12	.656	1.58	1.36	1-5/16

### Straight Thread O-Ring Run Tee Stainless Steel No. 7728x (Ref. SAE No. 080428)

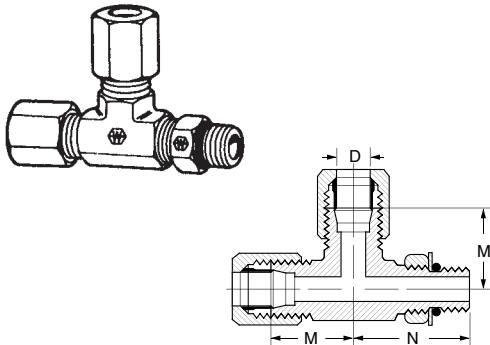

Replacement O-rings page 202.

Tube O.D.	Port Size	Catalog Number	D	M	N	Across Flats
1/4	1/4	7716x4	.203	.89	1.03	7/16
3/8	3/8	7716x6	.281	1.05	1.25	9/16
1/2	1/2	7716x8	.422	1.25	1.45	3/4

### Male Branch Tee Stainless Steel No. 7617x (Ref. SAE No. 080425)

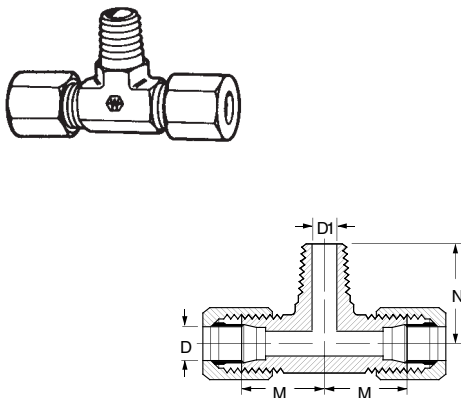

Tube O.D.	Male Pipe Thread	Catalog Number	D	D1	M	N	Across Flats
1/4	1/8	7605x4	.203	.188	.89	.78	7/16
1/4	1/4	7605x4x4x4	.203	.281	1.03	1.09	9/16
5/16	1/8	7605x5	.234	.188	.95	.81	9/16
3/8	1/4	7605x6	.281	.281	1.05	1.09	9/16
1/2	3/8	7605x8	.422	.406	1.25	1.22	3/4
1/2	1/2	7605x8x8x8	.422	.531	1.35	1.47	7/8
5/8	1/2	7605x10	.500	.531	1.42	1.47	7/8
3/4	3/4	7605x12	.656	.719	1.58	1.59	1-1/16
1	1	7605x16	.875	.938	1.73	1.97	1-5/16

### Female Branch Tee Stainless Steel No. 7667x (Ref. SAE No. 080427)

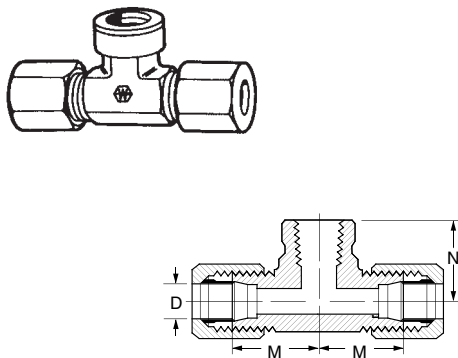

Tube O.D.	Female Pipe Thread	Catalog Number	D	M	N	Across Flats
1/4	1/8	7655x4	.203	.89	.66	9/16
1/4	1/4	7655x4x4x4	.203	1.03	.88	3/4
3/8	1/4	7655x6	.281	1.05	.88	3/4
1/2	3/8	7655x8	.422	1.23	1.02	7/8
5/8	1/2	7655x10	.500	1.42	1.23	1-1/16
3/4	3/4	7655x12	.656	1.58	1.36	1-5/16
7/8	3/4	7655x14	.718	1.62	1.42	1-5/16
1	1	7655x16	.875	1.73	1.62	1-5/8
1-1/4	1-1/4	7655x20	1.093	2.08	1.70	1-7/8

**Straight Thread O-Ring Branch Tee**

**Stainless Steel No. 7727x**  
(Ref. SAE No. 080429)

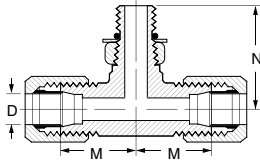
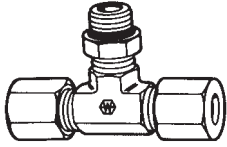

Replacement O-rings see below.

Tube O.D.	Port Size	Catalog Number	D	M	N	Across Flats
1/4	1/4	7715x4	.203	.89	1.03	7/16
3/8	3/8	7715x6	.281	1.05	1.25	9/16
1/2	1/2	7715x8	.422	1.25	1.45	3/4

**Cross**

**Stainless Steel No. 7967x**  
(Ref. SAE No. 080501)

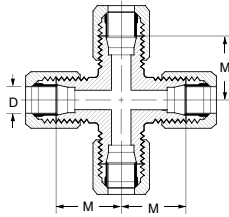
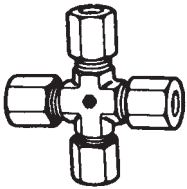

\*Brazed construction.

Tube O.D.	Catalog Number	D	M	Across Flats
1/4	7955x4*	.203	.89	9/16
3/8	7955x6*	.281	1.05	9/16
1/2	7955x8	.422	1.25	3/4

**Straight Thread O-Ring**

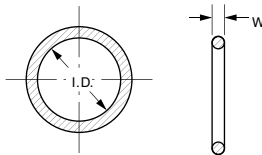

**Material:** Buna-N 90 Durometer  
**Temperature Range:** -40°F to +250°F  
(-40°C to +121°C)  
Standard O-ring complies with SAE J515 Type CH.

Tube O.D.	Catalog Number	W	I.D.
1/16	7629x1	.058 ± .003	.185 ± .005
1/8	7629x2	.064 ± .003	.239 ± .005
3/16	7629x3	.064 ± .003	.301 ± .005
1/4	7629x4	.072 ± .003	.351 ± .005
5/16	7629x5	.072 ± .003	.414 ± .005
3/8	7629x6	.078 ± .003	.468 ± .005
7/16	7629x7	.082 ± .003	.530 ± .005
1/2	7629x8	.087 ± .003	.644 ± .005
5/8	7629x10	.097 ± .003	.755 ± .005
3/4	7629x12	.116 ± .004	.924 ± .006
7/8	7629x14	.116 ± .004	1.048 ± .006
1	7629x16	.116 ± .004	1.171 ± .006
1-1/4	7629x20	.118 ± .004	1.475 ± .010
1-1/2	7629x24	.118 ± .004	1.720 ± .010
2	7629x32	.118 ± .004	2.337 ± .010

# Straight Thread O-Ring

**Steel  
Fittings**

 Refer to safety information regarding tubing selection on page 1.

- **Typical Application:** Pressure hydraulic systems.
- **Sealing Method:** Performed by an elastometric O-ring.
- **NOTE:** For pressure, material and plating information, refer to appropriate steel fitting sections of this catalog:

Pipe - See page 141. For-Seal - See page 149. SAE 37° - See page 159.

Ermeto - See page 190. Swivel Adapters - See page 214.

## Straight Thread O-Ring Hex Socket Plug (Ref. SAE No. 090109B)

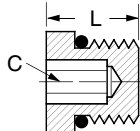

Replacement O-rings page 213.  
**NOTE:** Parts furnished with zinc plate.

Port Size	Catalog Number	Hex C	L
1/8	7238x2	1/8	.40
3/16	7238x3	1/8	.40
1/4	7238x4	3/16	.47
5/16	7238x5	3/16	.47
3/8	7238x6	1/4	.50
1/2	7238x8	5/16	.58
5/8	7238x10	3/8	.65
3/4	7238x12	9/16	.77
7/8	7238x14	9/16	.77
1	7238x16	5/8	.77
1-1/4	7238x20	3/4	.78

## Straight Thread O-Ring Hex Head Plug (Ref. SAE No. 090109A)

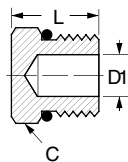
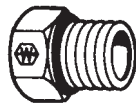

Replacement O-rings page 213.  
**NOTE:** Parts furnished with zinc plate.

Port Size	Catalog Number	Hex C	L	D1 Opt.
1/8	7237x2	7/16	.60	.093
3/16	7237x3	1/2	.60	.125
1/4	7237x4	9/16	.67	.203
5/16	7237x5	5/8	.67	.234
3/8	7237x6	11/16	.73	.297
1/2	7237x8	7/8	.80	.422
5/8	7237x10	1	.93	.500
3/4	7237x12	1-1/4	1.09	.656
7/8	7237x14	1-3/8	1.09	.718
1	7237x16	1-1/2	1.12	.875
1-1/4	7237x20	1-7/8	1.20	1.093
1-1/2	7237x24	2-1/8	1.27	1.344
2	7237x32	2-3/4	1.42	1.815

## Male Straight Thread/Female Straight Thread O-Ring Boss

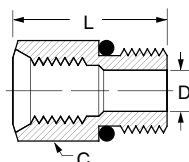
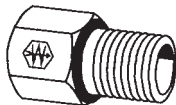

Replacement O-rings page 213.

Male Port Size	Fem. Port Size	Catalog Number	Hex C	D	L
1/2	3/8	7033x8x6	7/8	.391	1.16
5/8	1/2	7033x10x8	1	.484	1.34
3/4	1/2	7033x12x8	1-1/4	.671	1.44
7/8	3/4	7033x14x12	1-3/8	.719	1.72
1	1/2	7033x16x8	1-1/2	.687	1.12
1	3/4	7033x16x12	1-1/2	.844	1.70
1-1/4	3/4	7033x20x12	1-7/8	.968	1.20
1-1/2	1-1/4	7033x24x20	2-1/8	1.312	1.75
2	1-1/2	7033x32x24	2-3/4	1.781	1.44

## Straight Thread O-Ring Union

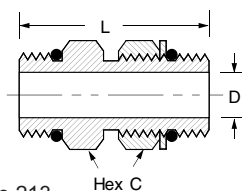

Replacement O-rings page 213.

Port Size	Catalog Number	Hex C	D	L
1/4	C5314x4x4	9/16	.172	1.37
3/8	C5314x6x6	11/16	.297	1.50
1/2	C5314x8x8	7/8	.391	1.56
5/8	C5314x10x10	1	.484	1.80
3/4	C5314x12x12	1-1/4	.609	2.33
1	C5314x16x16	1-1/2	.844	2.28
1-1/4	C5314x20x20	1-7/8	1.078	2.13
1-1/2	C5314x24x24	2-1/8	1.312	2.13
2	C5314x32x32	2-3/4	1.781	2.13

STEEL

## Male Straight Thread O-Ring to Male Pipe Adapter

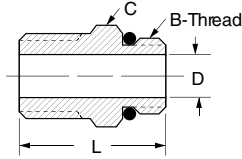
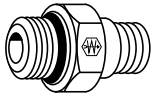

Replacement O-rings page 213.

Port Size	Male Pipe Thread	Catalog Number	Straight Thread B	Hex C	D	L
1/4	1/8	C3249x4x2	7/16-20	9/16	.172	1.05
3/8	1/4	C3249x6x4	9/16-18	11/16	.281	1.30
1/2	3/8	C3249x8x6	3/4-16	7/8	.391	1.36
1/2	1/2	C3249x8x8	3/4-16	7/8	.391	1.55
5/8	1/2	C3249x10x8	7/8-14	1	.484	1.69
3/4	3/4	C3249x12x12	1-1/16-12	1-1/4	.609	1.73
1	1	C3249x16x16	1-5/16-12	1-1/2	.844	2.06
1-1/4	1-1/4	C3249x20x20	1-5/8-12	1-7/8	1.078	2.17
1-1/2	1-1/2	C3249x24x24	1-7/8-12	2-1/8	1.312	2.26
2	2	C3249x32x32	2-1/2-12	2-3/4	1.781	2.47

## Straight Thread O-Ring to Female Pipe Adapter

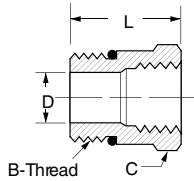
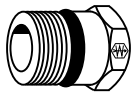

Replacement O-rings page 213.

Port Size	Female Pipe Thread	Catalog Number	Straight Thread B	Hex C	D	L
1/4	1/8	C3269x4x2	7/16-20	9/16	.172	.97
1/4	1/4	C3269x4x4	7/16-20	3/4	.172	1.16
5/16	1/8	C3269x5x2	1/2-20	5/8	.234	.94
3/8	1/4	C3269x6x4	9/16-18	3/4	.297	1.09
3/8	3/8	C3269x6x6	9/16-18	7/8	.281	1.30
3/8	1/2	C3269x6x8	9/16-18	1-1/8	.281	1.44
1/2	1/4	C3269x8x4	3/4-16	7/8	.421	1.06
1/2	3/8	C3269x8x6	3/4-16	7/8	.421	1.22
1/2	1/2	C3269x8x8	3/4-16	1-1/16	.421	1.50
5/8	1/4	C3269x10x4	7/8-14	1	.422	.81
5/8	3/8	C3269x10x6	7/8-14	1	.500	1.25
5/8	1/2	C3269x10x8	7/8-14	1-1/8	.500	1.50
5/8	3/4	C3269x10x12	7/8-14	1-3/8	.500	1.62
3/4	1/2	C3269x12x8	1-1/16-12	1-1/4	.688	1.34
3/4	3/4	C3269x12x12	1-1/16-12	1-3/8	.656	1.66
7/8	3/4	C3269x14x12	1-3/16-12	1-3/8	.718	1.63
1	1/2	C3269x16x8	1-5/16-12	1-1/2	.688	1.00
1	3/4	C3269x16x12	1-5/16-12	1-1/2	.876	1.50
1	1	C3269x16x16	1-5/16-12	1-5/8	.876	1.88
1-1/4	1	C3269x20x16	1-5/8-12	1-7/8	1.080	1.00
1-1/4	1-1/4	C3269x20x20	1-5/8-12	2	1.080	1.94
1-1/2	1-1/2	C3269x24x24	1-7/8-12	2-3/8	1.312	1.88
2	2	C3269x32x32	2-1/2-12	2-7/8	1.781	1.91

## Straight Thread O-Ring Connector (Ref. SAE No. 520120)

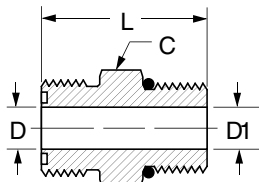

For replacement straight thread O-ring, see page 213.

Male Tube O.D.	Port Size	Catalog Number	Hex C	D	D1	L
1/4	1/4	4315x4	5/8	.172	.172	1.133
1/4	3/8	4315x4x6	11/16	.172	.172	1.202
3/8	5/8	4315x6x10	1-1/16	.264	.484	1.530
3/8	1/4	4315x6x4	3/4	.264	.172	1.343
3/8	3/8	4315x6	3/4	.264	.264	1.252
3/8	1/2	4315x6x8	7/8	.378	.264	1.378
1/2	5/8	4315x8x10	1	.378	.484	1.590
1/2	3/4	4315x8x12	1-1/4	.378	.609	1.748
1/2	3/8	4315x8x6	7/8	.378	.264	1.472
1/2	1/2	4315x8	7/8	.378	.378	1.441
5/8	5/8	4315x10	1-1/16	.484	.484	1.700
3/4	3/4	4315x12	1-1/4	.609	.609	1.918
3/4	1	4315x12x16	1-1/2	.609	.609	1.960
1	3/4	4315x16x12	1-1/2	.812	.609	2.138
1	1	4315x16	1-1/2	.811	.811	1.978
1	1-1/4	4315x16x20	1-7/8	.812	1.709	2.058
1-1/4	1	4315x20x16	1-3/4	1.024	.843	2.278
1-1/4	1-1/4	4315x20	1-7/8	1.024	1.024	2.058
1-1/2	1-1/2	4315x24	2-1/8	1.260	1.260	2.125

# Straight Thread O-Ring

**Steel  
Fittings**

## Straight Thread O-Ring Extended (Ref. SAE No. 520122)

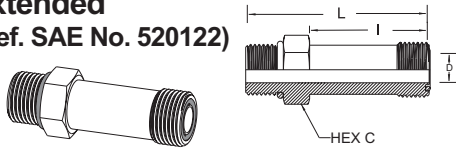

For replacement straight thread O-ring, see page 213.  
Replacement For-Seal O-ring page 158.

Male Tube O.D.	Port Size	Catalog Number	Hex C	D	I	L
3/8	3/8	4316x6	3/4	.264	1.46	2.27
1/2	1/2	4316x8	7/8	.378	1.75	2.67
3/4	3/4	4316x12	1-1/4	.609	2.52	3.76
1	1	4316x16	1-1/2	.811	2.87	4.14
1-1/4	1-1/4	4316x20	1-7/8	1.024	3.41	4.76
1-1/2	1-1/2	4316x24	2-1/8	1.260	3.82	5.26

## Female Straight Thread O-Ring to Male Pipe Adapter

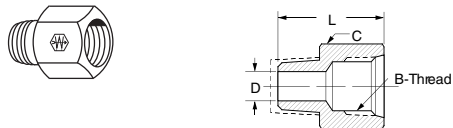

Fem. Port Size	Male Pipe Thread	Catalog Number	Straight Thread B	Hex C	D	L
3/8	3/8	C3239x6x6	9/16-18	13/16	.406	1.38
3/8	1/2	C3239x6x8	9/16-18	7/8	.500	1.61
1/2	3/8	C3239x8x6	3/4-16	1	.406	1.46
1/2	1/2	C3239x8x8	3/4-16	1	.562	1.69
5/8	1/2	C3239x10x8	7/8-14	1-1/4	.531	1.81

## Straight Thread O-Ring Connector to Ermeto® Stainless Steel No. 7327x (Ref. SAE No. 080120)

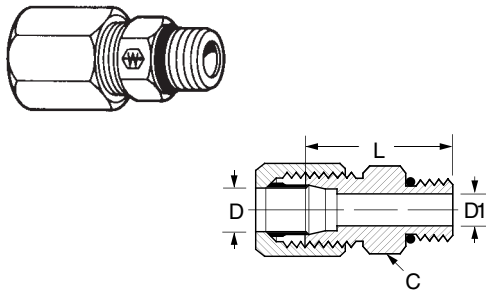

Replacement O-rings page 213.

Tube O.D.	Port Size	Catalog Number	Hex C	D	L	D1 Opt.
3/16	3/16	7315x3	1/2	.125	1.04	-
1/4	1/4	7315x4	9/16	.203	1.13	-
1/4	5/16	7315x4x5	5/8	.203	1.13	-
1/4	3/8	7315x4x6	11/16	.203	1.19	.281
5/16	5/16	7315x5	5/8	.234	1.13	-
3/8	3/8	7315x6	11/16	.281	1.21	-
3/8	1/2	7315x6x8	7/8	.281	1.29	.422
1/2	1/2	7315x8	7/8	.422	1.38	-
1/2	5/8	7315x8x10	1	.422	1.51	.500
1/2	3/4	7315x8x12	1-1/4	.422	1.67	.656
5/8	5/8	7315x10	1	.500	1.57	-
3/4	3/4	7315x12	1-1/4	.656	1.79	-
3/4	1	7315x12x16	1-1/2	.656	1.82	.876
7/8	7/8	7315x14	1-3/8	.718	1.79	-
1	3/4	7315x16x12	1-1/2	.875	1.82	.656
1	1	7315x16	1-1/2	.875	1.82	-
1-1/4	1-1/4	7315x20	1-7/8	1.093	1.90	-
1-1/2	1-1/2	7315x24	2-1/8	1.344	1.97	-
2	2	7315x32	2-3/4	1.813	2.13	-

## Male Straight Thread O-Ring to Female Pipe Swivel (Ref. SAE No. 140157)

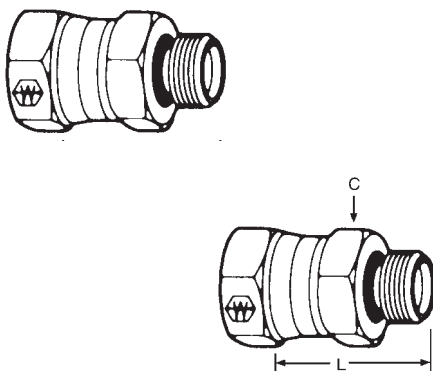

Replacement O-rings page 213.

Port Size	NPSM Swivel Nut	Catalog Number	Hex C	L	Across Flats
1/4	1/4-18	9315x4x4	9/16	.970	11/16
1/4	3/8-18	9315x4x6	5/8	1.060	11/16
5/16	1/4-18	9315x5x4	5/8	1.109	11/16
3/8	1/4-18	9315x6x4	11/16	1.171	11/16
3/8	3/8-18	9315x6x6	11/16	1.090	7/8
3/8	1/2-14	9315x6x8	13/16	1.210	1
1/2	1/4-18	9315x8x4	7/8	1.234	11/16
1/2	3/8-18	9315x8x6	7/8	1.200	7/8
1/2	1/2-14	9315x8x8	7/8	1.260	1
1/2	3/4-14	9315x8x12	1	1.406	1-1/4
5/8	3/8-18	9315x10x6	1	1.375	7/8
5/8	1/2-14	9315x10x8	1	1.400	1
5/8	3/4-14	9315x10x12	1	1.546	1-1/4
3/4	1/2-14	9315x12x8	1-1/4	1.540	1
3/4	3/4-14	9315x12x12	1-1/4	1.600	1-1/4
7/8	3/4-14	9315x14x12	1-3/8	1.703	1-1/4
1	3/4-14	9315x16x12	1-1/2	1.734	1-1/2
1	1-11-1/2	9315x16x16	1-1/2	1.710	1-1/2
1-1/4	1-11-1/2	9315x20x16	1-7/8	1.828	1-7/8
1-1/4	1-1/2-11-1/2	9315x20x20	1-7/8	1.890	1-7/8
1-1/2	1-1/2-11-1/2	9315x24x24	2-1/8	1.953	2-1/8
2	2-11-1/2	9315x32x32	2-3/4	2.156	2-5/8

STEEL

**Straight Thread O-Ring  
Connector to Male 37° SAE**  
Stainless Steel No. **5327x**  
(Ref. SAE No. 070120)  
Example assembly No. **C35315x4**

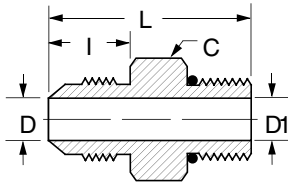
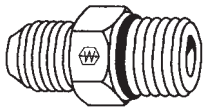

Replacement O-rings page 213.

Tube O.D.	Port Size	Catalog Number	Hex C	D	D1 Opt.	I	L
1/8	1/8	C5315x2	7/16	.062	.062	.45	1.06
3/16	3/16	C5315x3	1/2	.125	.125	.48	1.10
1/4	1/4	C5315x4	9/16	.172	.172	.55	1.23
1/4	5/16	C5315x4x5	5/8	.172	.234	.55	1.23
1/4	3/8	C5315x4x6	11/16	.172	.172	.55	1.29
1/4	1/2	C5315x4x8	7/8	.172	.391	.55	1.38
5/16	1/4	C5315x5x4	9/16	.234	.172	.55	1.23
5/16	5/16	C5315x5	5/8	.234	.234	.55	1.23
5/16	3/8	C5315x5x6	11/16	.234	.297	.55	1.30
3/8	1/4	C5315x6x4	5/8	.297	.172	.56	1.33
3/8	5/16	C5315x6x5	5/8	.297	.234	.56	1.30
3/8	3/8	C5315x6	11/16	.297	.297	.56	1.30
3/8	1/2	C5315x6x8	7/8	.297	.391	.56	1.38
3/8	5/8	C5315x6x10	1	.297	.484	.56	1.50
1/2	3/8	C5315x8x6	13/16	.391	.297	.66	1.44
1/2	1/2	C5315x8	7/8	.391	.391	.66	1.48
1/2	5/8	C5315x8x10	1	.391	.484	.66	1.60
1/2	3/4	C5315x8x12	1-1/4	.391	.609	.66	1.76
5/8	1/2	C5315x10x8	15/16	.484	.391	.76	1.67
5/8	5/8	C5315x10	1	.484	.484	.76	1.70
5/8	3/4	C5315x10x12	1-1/4	.484	.609	.76	1.86
5/8	1	C5315x10x16	1-1/2	.484	.844	.76	1.89
3/4	1/2	C5315x12x8	1-1/8	.609	.391	.86	1.94
3/4	5/8	C5315x12x10	1-1/8	.609	.484	.86	1.88
3/4	3/4	C5315x12	1-1/4	.609	.609	.86	1.97
3/4	7/8	C5315x12x14	1-3/8	.609	.718	.86	1.97
3/4	1	C5315x12x16	1-1/2	.609	.844	.86	1.99
3/4	1-1/4	C5315x12x20	1-7/8	.609	1.078	.86	2.08
7/8	7/8	C5315x14	1-3/8	.718	.718	.89	1.99
1	5/8	C5315x16x10	1-3/8	.844	.484	.91	1.95
1	3/4	C5315x16x12	1-3/8	.844	.609	.91	2.04
1	1	C5315x16	1-1/2	.844	.844	.91	2.04
1	1-1/4	C5315x16x20	1-7/8	.844	1.078	.91	2.12
1-1/4	1	C5315x20x16	1-11/16	1.078	.844	.96	2.20
1-1/4	1-1/4	C5315x20	1-7/8	1.078	1.078	.96	2.17
1-1/4	1-1/2	C5315x20x24	2-1/8	1.078	1.312	.96	2.25
1-1/2	1-1/4	C5315x24x20	2	1.312	1.078	1.08	2.34
1-1/2	1-1/2	C5315x24	2-1/8	1.312	1.312	1.08	2.37
1-1/2	2	C5315x24x32	2-3/4	1.312	1.781	1.08	2.53
2	1-1/2	C5315x32x24	2-5/8	1.781	1.312	1.33	2.78
2	2	C5315x32	2-3/4	1.784	1.784	1.33	2.78

**Straight Thread O-Ring  
Extended Connector to Male  
37° SAE**  
(Ref. SAE No. 070122)  
Example assembly No. **C35316x4**

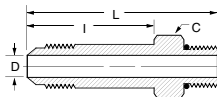
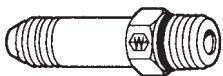

Replacement O-rings page 213.

Tube O.D.	Port Size	Catalog Number	Hex C	D	I	L
1/4	1/4	C5316x4	9/16	.172	1.39	2.08
3/8	3/8	C5316x6	11/16	.297	1.56	2.31
1/2	1/2	C5316x8	7/8	.391	1.88	2.70
5/8	5/8	C5316x10	1	.484	2.09	3.04
3/4	3/4	C5316x12	1-1/4	.609	2.50	3.61
1	1	C5316x16	1-1/2	.844	2.84	3.98
1-1/4	1-1/4	C5316x20	1-7/8	1.078	3.47	4.69



# Straight Thread O-Ring

**Steel Fittings**

## Straight Thread O-Ring to Female 37° Swivel

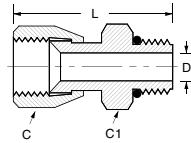
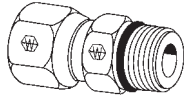

Replacement O-rings page 213.

Tube O.D.	Port Size	Catalog Number	Hex C	Hex C1	L	D
1/4	1/4	C5216x4x4	9/16	.56	.95	.172
1/4	3/8	C5216x4x6	9/16	.69	1.00	.172
3/8	3/8	C5216x6x6	11/16	.69	1.11	.297
3/8	1/2	C5216x6x8	11/16	.88	1.18	.297
1/2	3/8	C5216x8x6	7/8	3/4	1.71	.297
1/2	1/2	C5216x8x8	7/8	.88	1.17	.391
5/8	5/8	C5216x10x10	1	1.00	1.45	.484
3/4	3/4	C5216x12x12	1-1/4	1.25	1.61	.609
1	1	C5216x16x16	1-1/2	1.50	1.69	.844
1-1/4	1-1/4	C5216x20x20	2	1.88	1.82	1.078
1-1/2	1-1/2	C5216x24x24	2-1/8	2.12	1.88	1.312
2	2	C5216x32x32	2-3/4	2.75	2.01	1.781

## Straight Thread O-Ring 45° Elbow to Male 37° SAE (Ref. SAE No. 070320) Example assembly No. C35365x4

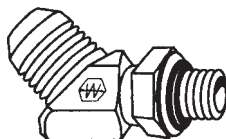
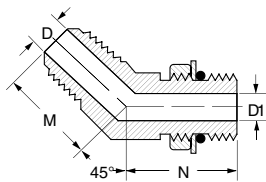
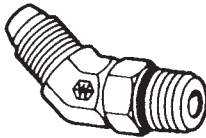

Replacement O-rings page 213.  
\*Special order only.

Tube O.D.	Port Size	Catalog Number	D	D1	M	N	Across Flats
1/4	1/4	C5365x4	.172	.172	.72	1.05	7/16
5/16	5/16	C5365x5*	.234	.234	.77	1.05	9/16
3/8	3/8	C5365x6	.297	.297	.83	1.14	9/16
1/2	1/2	C5365x8	.391	.391	.98	1.30	3/4
1/2	5/8	C5365x8x10	.391	.484	.99	1.52	7/8
5/8	5/8	C5365x10	.484	.484	1.11	1.52	7/8
3/4	5/8	C5365x12x10	.609	.484	1.28	1.57	1-1/16
3/4	3/4	C5365x12	.609	.609	1.28	1.73	1-1/16
1	1	C5365x16	.844	.844	1.47	1.86	1-5/16
1-1/4	1-1/4	C5365x20	1.078	1.078	1.59	1.91	1-5/8
1-1/2	1-1/2	C5365x24*	1.312	1.312	1.78	1.91	1-7/8
1/4	1/4	TF5365x4	.172	.172	.72	1.05	1/2
5/16	5/16	TF5365x5	.234	.234	.77	1.05	9/16
3/8	3/8	TF5365x6	.297	.297	.83	1.14	5/8
3/8	1/2	TF5365x6x8	.297	.391	.87	1.30	13/16
1/2	3/8	TF5365x8x6	.391	.297	.98	1.17	13/16
1/2	1/2	TF5365x8	.391	.391	.98	1.30	13/16
1/2	5/8	TF5365x8x10	.391	.484	.99	1.52	15/16
5/8	1/2	TF5365x10x8	.484	.391	1.09	1.41	15/16
5/8	5/8	TF5365x10	.484	.484	1.09	1.52	15/16
3/4	5/8	TF5365x12x10	.609	.484	1.30	1.58	1-1/8
3/4	3/4	TF5365x12	.609	.609	1.28	1.73	1-1/8
3/4	1	TF5365x12x16	.609	.844	1.45	1.86	1-3/8
7/8	7/8	TF5365x14	.718	.718	1.39	1.80	1-1/4
1	3/4	TF5365x16x12	.844	.609	1.47	1.86	1-3/8
1	1	TF5365x16	.844	.844	1.47	1.86	1-3/8
1-1/4	1-1/4	TF5365x20	1.078	1.078	1.59	1.91	1-3/4
1-1/2	1-1/2	TF5365x24	1.312	1.312	1.78	1.91	2
2	2	TF5365x32	1.781	1.781	2.22	1.86	2-5/8

STEEL

## Straight Thread O-Ring Connector 45° Elbow (Ref. SAE No. 520320)

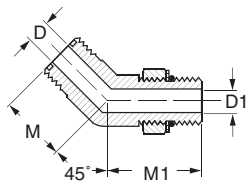
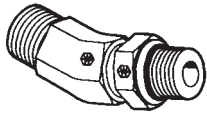

For replacement straight thread O-rings, see page 213.

Male Tube O.D.	Male Port Size	Catalog Number	D	D1	M	M1	Across Flats
1/4	1/4	<a href="#">4365x4</a>	.172	.172	.63	1.18	9/16
3/8	3/8	<a href="#">4365x6</a>	.264	.264	.74	1.30	3/4
1/2	1/2	<a href="#">4365x8</a>	.378	.390	.80	1.43	3/4
5/8	5/8	<a href="#">4365x10</a>	.484	.484	.92	1.76	1-1/16
3/4	3/4	<a href="#">4365x12</a>	.609	.609	1.02	1.97	1-5/16
1	1	<a href="#">4365x16</a>	.812	.811	1.18	2.06	1-7/16

## Male Straight Thread O-Ring 45° Elbow to Female Pipe Swivel (Ref. SAE No. 140357)

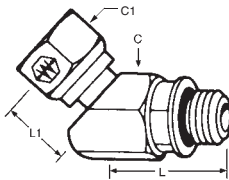
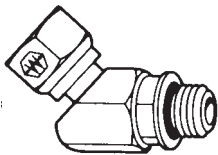

Replacement O-rings page 213.

Port Size	NPSM Swivel Nut	Catalog Number	Hex C	Hex C1	L	L1
1/4	1/4-18	<a href="#">9365x4x4</a>	7/16	11/16	1.06	.66
1/4	3/8-18	<a href="#">9365x4x6</a>	7/16	7/8	1.00	.75
3/8	3/8-18	<a href="#">9365x6x6</a>	9/16	7/8	1.06	.70
3/8	1/2-14	<a href="#">9365x6x8</a>	9/16	1	1.13	.82
1/2	3/8-18	<a href="#">9365x8x6</a>	3/4	1	1.13	.88
1/2	1/2-14	<a href="#">9365x8x8</a>	3/4	1	1.13	.82
5/8	1/2-14	<a href="#">9365x10x8</a>	7/8	1	1.50	.78
3/4	3/4-14	<a href="#">9365x12x12</a>	1-1/16	1-1/4	1.50	1.05
1	1-11-1/2	<a href="#">9365x16x16</a>	1-5/16	1-1/2	1.62	1.06
1-1/4	1-1/4-11-1/2	<a href="#">9365x20x20</a>	1-5/8	1-7/8	2.28	1.17
1-1/2	1-1/2-11-1/2	<a href="#">9365x24x24</a>	1-7/8	2-1/8	2.61	1.34

## 90° Straight Thread O-Ring Male Elbow to Male Pipe

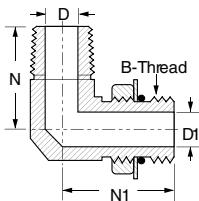
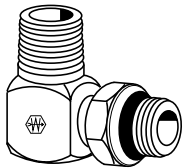

Replacement O-rings page 213.

Port Size	Male Pipe Thread	Catalog Number	Straight Thread B	D1	D	N	N1	Across Flats
1/4	1/8	<a href="#">TF3569x4</a>	7/16-20	.172	.188	.78	1.03	1/2
5/16	1/8	<a href="#">TF3569x5</a>	1/2-20	.234	.188	.78	1.09	9/16
3/8	1/4	<a href="#">TF3569x6</a>	9/16-18	.297	.281	1.09	1.25	5/8
1/2	3/8	<a href="#">TF3569x8</a>	3/4-16	.391	.406	1.22	1.45	13/16
5/8	1/2	<a href="#">TF3569x10</a>	7/8-14	.484	.531	1.47	1.70	15/16
3/4	3/4	<a href="#">TF3569x12</a>	1-1/16-12	.609	.719	1.59	1.94	1-1/8
7/8	3/4	<a href="#">TF3569x14</a>	1-3/16-12	.719	.719	1.69	2.00	1-1/4
1	1	<a href="#">TF3569x16</a>	1-5/16-12	.844	.938	1.97	2.05	1-3/8
1-1/4	1-1/4	<a href="#">TF3569x20</a>	1-5/8-12	1.078	1.250	2.38	2.25	1-3/4
1-1/2	1-1/2	<a href="#">TF3569x24</a>	1-7/8-12	1.312	1.500	2.64	2.39	2
2	2	<a href="#">TF3569x32</a>	2-1/2-12	1.781	1.938	3.00	2.89	2-5/8

# Straight Thread O-Ring

**Steel Fittings**

## Straight Thread O-Ring 90° Elbow to Male 37° SAE

Stainless Steel **5527x**

(Ref. SAE No. 070220)

Example assembly No. C35515x4

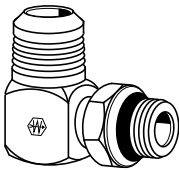
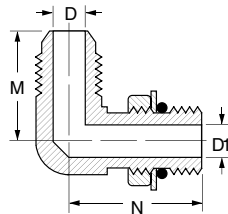
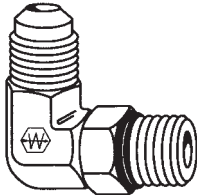

Replacement O-rings page 213.

\*Special Order Only

## Straight Thread O-Ring 90° Elbow Long to Male 37° SAE

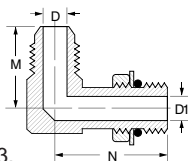
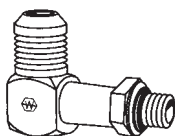

Replacement O-rings page 213.

Tube O.D.	Port Size	Catalog Number	D	D1	M	N	Across Flats
3/16	3/16	C5515x3	.125	.125	.83	.94	7/16
1/4	1/4	C5515x4	.172	.172	.89	1.03	7/16
5/16	5/16	C5515x5	.234	.234	.95	1.13	9/16
3/8	3/8	C5515x6	.297	.297	1.06	1.25	9/16
3/8	1/2	C5515x6x8	.297	.391	1.14	1.45	3/4
1/2	3/8	C5515x8x6	.391	.297	1.25	1.32	3/4
1/2	1/2	C5515x8	.391	.391	1.25	1.45	3/4
1/2	5/8	C5515x8x10	.391	.484	1.33	1.70	7/8
5/8	5/8	C5515x10	.484	.484	1.45	1.70	7/8
3/4	5/8	C5515x12x10	.609	.484	1.66	1.78	1-1/16
3/4	3/4	C5515x12	.609	.609	1.66	1.94	1-1/16
7/8	7/8	C5515x14	.718	.718	1.73	2.00	1-5/16
1	3/4	C5515x16x12	.844	.609	1.81	2.05	1-5/16
1	1	C5515x16	.844	.844	1.81	2.05	1-5/16
1-1/4	1-1/4	C5515x20	1.078	1.078	2.06	2.25	1-5/8
1-1/2	1-1/2	C5515x24*	1.312	1.312	2.33	2.39	1-7/8
1/4	1/4	TF5515x4	.172	.172	.89	1.03	1/2
1/4	5/16	TF5515x4x5	.172	.234	.95	1.12	5/8
1/4	3/8	TF5515x4x6	.172	.297	.95	1.25	5/8
5/16	1/4	TF5515x5x4	.234	.172	.98	1.06	9/16
5/16	5/16	TF5515x5	.234	.234	.95	1.09	9/16
5/16	3/8	TF5515x5x6	.234	.297	.98	1.25	5/8
3/8	1/4	TF5515x6x4	.297	.172	1.06	1.09	5/8
3/8	5/16	TF5515x6x5	.297	.234	1.06	1.12	5/8
3/8	3/8	TF5515x6	.297	.297	1.06	1.25	5/8
3/8	1/2	TF5515x6x8	.297	.391	1.16	1.45	13/16
3/8	5/8	TF5515x6x10	.297	.484	1.22	1.70	15/16
1/2	3/8	TF5515x8x6	.391	.297	1.25	1.34	13/16
1/2	1/2	TF5515x8	.391	.391	1.25	1.45	13/16
1/2	5/8	TF5515x8x10	.391	.484	1.31	1.70	15/16
1/2	3/4	TF5515x8x12	.391	.609	1.41	1.94	1-1/8
5/8	1/2	TF5515x10x8	.484	.391	1.45	1.52	15/16
5/8	5/8	TF5515x10	.484	.484	1.45	1.70	15/16
5/8	3/4	TF5515x10x12	.484	.609	1.55	1.94	1-1/8
3/4	1/2	TF5515x12x8	.609	.391	1.66	1.61	1-1/8
3/4	5/8	TF5515x12x10	.609	.484	1.66	1.80	1-1/8
3/4	3/4	TF5515x12	.609	.609	1.66	1.94	1-1/8
3/4	7/8	TF5515x12x14	.609	.718	1.72	2.00	1-1/4
3/4	1	TF5515x12x16	.609	.844	1.78	2.05	1-3/8
7/8	7/8	TF5515x14	.718	.718	1.73	2.00	1-5/16
1	3/4	TF5515x16x12	.844	.609	1.81	2.06	1-3/8
1	7/8	TF5515x16x14	.844	.718	1.81	2.06	1-3/8
1	1	TF5515x16	.844	.844	1.81	2.05	1-3/8
1	1-1/4	TF5515x16x20	.844	1.078	2.00	2.25	1-3/4
1-1/4	1	TF5515x20x16	1.078	.844	2.06	2.23	1-3/4
1-1/4	1-1/4	TF5515x20	1.078	1.078	2.06	2.25	1-3/4
1-1/2	1-1/4	TF5515x24x20	1.312	1.078	2.33	2.37	2
1-1/2	1-1/2	TF5515x24	1.312	1.312	2.33	2.39	2
2	2	TF5515x32	1.781	1.781	3.06	2.89	2-5/8

STEEL

## Straight Thread O-Ring 90° Elbow Extra Long to Male 37°

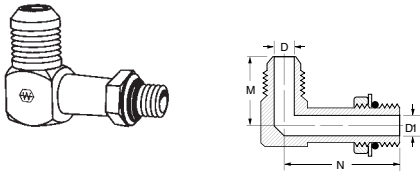

Replacement O-rings page 213.

Tube O.D.	Port Size	Catalog Number	D	D1	M	N	Across Flats
3/8	3/8	<a href="#">TF5515x6LL</a>	.297	.297	1.06	2.08	5/8
1/2	1/2	<a href="#">TF5515x8LL</a>	.391	.391	1.25	2.50	13/16
5/8	5/8	<a href="#">TF5515x10LL</a>	.484	.484	1.45	3.25	15/16
3/4	3/4	<a href="#">TF5515x12LL</a>	.609	.609	1.66	3.34	1-1/8

## Straight Thread O-Ring 90° Elbow (Ref. SAE No. 520220)

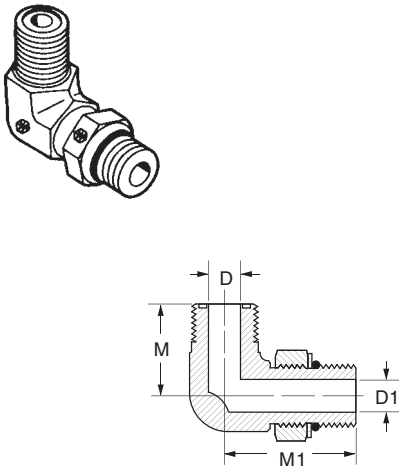

Replacement Straight Thread O-rings page 213.  
Replacement For-Seal O-rings page 158.

Male Tube O.D.	Port Size	Catalog Number	D	D1	M	M1	Across Flats
1/4	1/4	<a href="#">4515x4</a>	.172	.172	.85	1.29	9/16
1/4	3/8	<a href="#">4515x4x6</a>	.172	.264	.92	1.45	3/4
3/8	1/2	<a href="#">4515x6x8</a>	.264	.390	1.04	1.60	3/4
3/8	3/8	<a href="#">4515x6</a>	.264	.264	.98	1.45	3/4
1/2	3/8	<a href="#">4515x8x6</a>	.378	.264	1.10	1.44	3/4
1/2	1/2	<a href="#">4515x8</a>	.378	.390	1.10	1.60	3/4
5/8	5/8	<a href="#">4515x10</a>	.484	.484	1.31	1.97	1-1/16
3/4	3/4	<a href="#">4515x12</a>	.609	.609	1.47	2.17	1-5/16
1	1	<a href="#">4515x16</a>	.811	.811	1.64	2.35	1-5/8

## Straight Thread O-Ring 90° Elbow to Ermeto® Stainless Steel No. 7527x (Ref. SAE No. 080220)

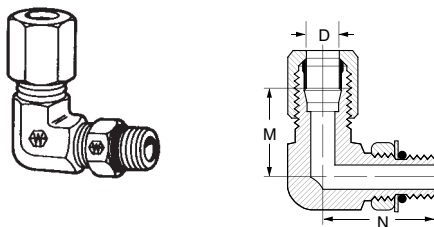

Replacement O-rings page 213.

Tube O.D.	Port Size	Catalog Number	D	M	N	Across Flats
1/4	1/4	<a href="#">7515x4</a>	.203	.89	1.03	7/16
5/16	5/16	<a href="#">7515x5</a>	.234	.96	1.13	9/16
3/8	3/8	<a href="#">7515x6</a>	.281	1.05	1.25	9/16
1/2	1/2	<a href="#">7515x8</a>	.422	1.25	1.45	3/4
5/8	5/8	<a href="#">7515x10</a>	.500	1.42	1.70	7/8
3/4	3/4	<a href="#">7515x12</a>	.656	1.58	1.94	1-1/16
1	1	<a href="#">7515x16</a>	.875	1.73	2.05	1-5/16
1	3/4	<a href="#">7515x16x12</a>	.875	1.73	2.05	1-5/16
1-1/4	1-1/4	<a href="#">7515x20</a>	1.093	1.89	2.25	1-5/8

# Straight Thread O-Ring

**Steel Fittings**

## Male Straight Thread O-Ring 90° Elbow to Female Pipe Swivel (Ref. SAE No. 140257)

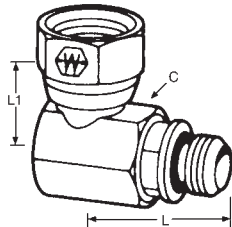

Replacement O-rings page 213.

Port Size	NPSM Swivel Nut	Catalog Number	Hex C	L	L1	Across Flats
1/4	1/4-18	9515x4x4	11/16	1.02	.75	11/16
1/4	3/8-18	9515x4x6	7/8	1.10	.90	7/8
3/8	1/4-18	9515x6x4	11/16	1.19	.78	11/16
3/8	3/8-18	9515x6x6	7/8	1.17	.90	7/8
3/8	1/2-14	9515x6x8	1	1.25	1.02	1
1/2	3/8-18	9515x8x6	1	1.36	1.00	1
1/2	1/2-14	9515x8x8	1	1.36	1.02	1
1/2	3/4-14	9515x8x12	1-1/4	1.66	1.25	1-1/4
5/8	3/8-18	9515x10x6	1	1.64	1.00	1
5/8	1/2-14	9515x10x8	1	1.50	1.02	1
5/8	3/4-14	9515x10x12	1-1/4	1.78	1.25	1-1/4
3/4	1/2-14	9515x12x8	1-1/4	1.92	1.12	1-1/4
3/4	3/4-14	9515x12x12	1-1/4	1.79	1.20	1-1/4
7/8	3/4-14	9515x14x12	1-1/4	1.92	1.25	1-1/4
1	3/4-14	9515x16x12	1-1/2	2.09	1.38	1-1/2
1	1-11-1/2	9515x16x16	1-1/2	2.09	1.39	1-1/2
1-1/4	3/4-14	9515x20x12	1-7/8	2.48	1.56	1-7/8
1-1/4	1-1/4-11-1/2	9515x20x20	1-7/8	2.48	1.66	1-7/8
1-1/2	1-1/2-11-1/2	9515x24x24	2-1/8	2.61	1.73	2-1/8
2	2-11-1/2	9515x32x32	2-5/8	3.25	2.31	2-5/8

## Straight Thread O-Ring 90° Elbow to Female Pipe

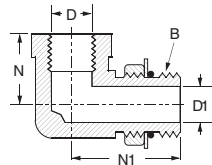
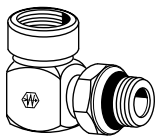
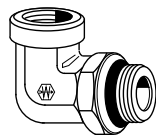

Replacement O-rings page 213.

Port Size	Fem. Pipe Thread	Catalog Number	Straight Thread B	D	D1	N	N1	Across Flats
1/2	3/8	C3459x8	3/4-16	.562	.422	.63	1.47	7/8
5/8	1/2	C3459x10	7/8-14	.687	.500	.75	1.81	1-1/16
3/4	3/4	C3459x12	1-1/16-12	.906	.656	.81	2.00	1-5/16
1	1	C3459x16	1-5/16-12	1.125	.876	1.00	2.25	1-5/8
1/4	1/8	TF3459x4	7/16-20	.332	.172	.66	1.09	5/8
5/16	1/8	TF3459x5	1/2-20	.332	.234	.66	1.13	5/8
3/8	1/4	TF3459x6	9/16-18	.437	.297	.88	1.31	3/4
1/2	3/8	TF3459x8	3/4-16	.562	.391	1.02	1.49	7/8
5/8	1/2	TF3459x10	7/8-14	.687	.484	1.23	1.80	1-1/8
3/4	3/4	TF3459x12	1-1/16-12	.906	.609	1.36	2.06	1-3/8
7/8	3/4	TF3459x14	1-3/16-12	.906	.719	1.42	2.06	1-3/8
1	1	TF3459x16	1-5/16-12	1.125	.844	1.62	2.17	1-5/8
1-1/4	1-1/4	TF3459x20	1-5/8-12	1.468	1.078	1.70	2.38	2
1-1/2	1-1/2	TF3459x24	1-7/8-12	1.703	1.312	2.08	2.58	2-3/8
2	2	TF3459x32	2-1/2-12	2.180	1.781	2.39	3.02	2-7/8

## Straight Thread O-Ring 90° Elbow Long to Female Pipe

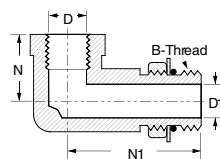
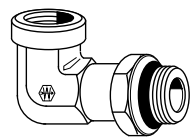

Replacement O-rings page 213.

Port Size	Fem. Pipe Thread	Catalog Number	Straight Thread B	D	D1	N	N1	Across Flats
1/2	3/8	C3469x8	3/4-16	.562	.422	.63	2.94	7/8
5/8	1/2	C3469x10	7/8-14	.687	.500	.75	3.56	1-1/16
3/4	3/4	C3469x12	1-1/16-12	.906	.656	.81	4.13	1-5/16
1	1	C3469x16	1-5/16-12	1.125	.876	1.00	4.63	1-5/8

STEEL

**Straight Thread O-Ring Run Tee to Male 37° SAE**  
(Ref. SAE No. 070428)  
Example assembly No. C35716x4

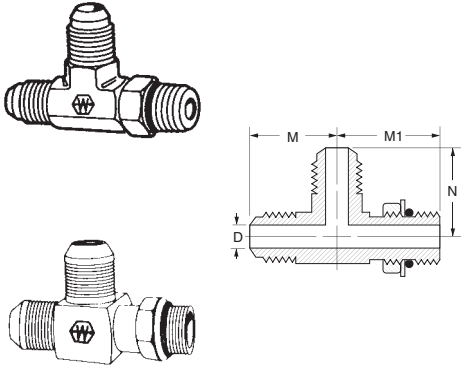

Replacement O-rings page 213.

Tube O.D.	Port Size	Catalog Number	D	M	N	Across Flats
1/4	1/4	C5716x4	.172	.89	1.03	7/16
5/16	5/16	C5716x5	.234	.95	1.09	9/16
3/8	3/8	C5716x6	.297	1.06	1.25	9/16
1/2	1/2	C5716x8	.391	1.25	1.45	3/4
5/8	5/8	C5716x10	.484	1.45	1.70	7/8
3/4	3/4	C5716x12	.609	1.66	1.94	1-1/16
1	1	C5716x16	.844	1.81	2.05	1-5/16
1-1/4	1-1/4	C5716x20	1.078	2.06	2.25	1-5/8
1/4	1/4	TF5716x4	.172	.89	1.03	1/2
5/16	5/16	TF5716x5	.234	.95	1.09	9/16
3/8	3/8	TF5716x6	.297	1.06	1.25	5/8
1/2	1/2	TF5716x8	.391	1.25	1.45	13/16
5/8	5/8	TF5716x10	.484	1.45	1.70	15/16
3/4	3/4	TF5716x12	.609	1.66	1.94	1-1/8
7/8	7/8	TF5716x14	.718	1.73	2.00	1-1/4
1	1	TF5716x16	.844	1.81	2.05	1-3/8
1-1/4	1-1/4	TF5716x20	1.078	2.06	2.25	1-3/4
1-1/2	1-1/2	TF5716x24	1.312	2.33	2.39	2

**Straight Thread O-Ring Branch Tee to Male 37° SAE**  
(Ref. SAE No. 070429)  
Example assembly No. C35715x4

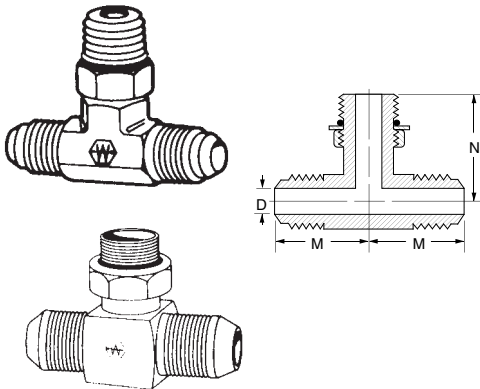

Replacement O-rings page 213.  
\*Special order only.

Tube O.D.	Port Size	Catalog Number	D	M	N	Across Flats
1/4	1/4	C5715x4	.172	.89	1.03	7/16
5/16	5/16	C5715x5*	.234	.95	1.09	9/16
3/8	3/8	C5715x6	.297	1.06	1.25	9/16
1/2	1/2	C5715x8	.391	1.25	1.45	3/4
5/8	5/8	C5715x10	.484	1.45	1.70	7/8
3/4	3/4	C5715x12	.609	1.66	1.94	1-1/16
1	1	C5715x16	.844	1.81	2.05	1-5/16
1/4	1/4	TF5715x4	.172	.89	1.03	7/16
5/16	5/16	TF5715x5	.234	.95	1.09	9/16
3/8	3/8	TF5715x6	.297	1.06	1.25	5/8
1/2	1/2	TF5715x8	.391	1.25	1.45	3/4
5/8	5/8	TF5715x10	.484	1.45	1.70	15/16
3/4	3/4	TF5715x12	.609	1.66	1.94	1-1/8
7/8	7/8	TF5715x14	.719	1.73	2.00	1-1/4
1	1	TF5715x16	.844	1.81	2.05	1-3/8
1-1/4	1-1/4	TF5715x20	1.078	2.06	2.25	1-3/4
1-1/2	1-1/2	TF5715x24	1.312	2.33	2.39	2

**Straight Thread O-Ring Run Tee to Ermeto®**  
(Stainless Steel No. 7728x)  
(Ref. SAE No. 080428)

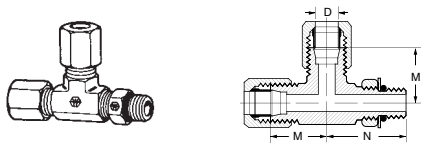

Replacement O-rings page 213.

Tube O.D.	Port Size	Catalog Number	D	M	N	Across Flats
1/4	1/4	7716x4	.203	.89	1.03	7/16
3/8	3/8	7716x6	.281	1.05	1.25	9/16
1/2	1/2	7716x8	.422	1.25	1.45	3/4

# Straight Thread O-Ring

**Steel Fittings**

## Straight Thread O-Ring Branch Tee to Ermeto®

Stainless Steel No. 7727x  
(Ref. SAE No. 080429)

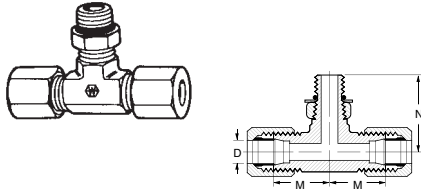

Replacement O-rings see below.

Tube O.D.	Port Size	Catalog Number	D	M	N	Across Flats
1/4	1/4	7715x4	.203	.89	1.03	7/16
3/8	3/8	7715x6	.281	1.05	1.25	9/16
1/2	1/2	7715x8	.422	1.25	1.45	3/4

## Straight Thread Branch Tee

(Ref. SAE No. 520429)

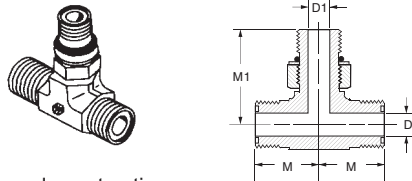

\*Brazed construction.  
For replacement straight thread O-ring, see below.  
For replacement FOR-SEAL® O-ring, see page 158.

Tube O.D.	Port Size	Catalog Number	D	D1	M	M1	Across Flats
1/4	1/4	4715x4	.172	.172	.85	1.29	9/16
3/8	3/8	4715x6	.264	.264	.98	1.45	3/4
3/8	1/2	4715x6x8	.264	.391	1.04	1.60	3/4
1/2	1/2	4715x8	.378	.390	1.10	1.60	3/4
5/8	5/8	4715x10	.484	.484	1.31	1.97	1-1/16
3/4	3/4	4715x12	.609	.609	1.47	2.17	1-3/16
1	1	4715x16	.811	.811	1.64	2.35	1-1/16

## Straight Thread Run Tee

(Ref. SAE No. 520428)

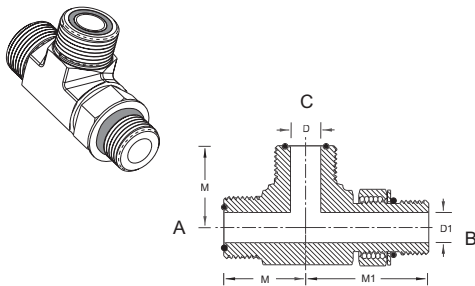

For replacement straight thread O-ring, see below.

Tube O.D. A	Tube O.D. B	Port Size C	Catalog Number	D	D1	M	M1	Across Flats
1/4	1/4	1/4	4716x4	.172	.172	.85	1.29	9/16
1/4	3/8	1/4	4716x4x6	.172	.264	1.39	1.45	3/4
3/8	3/8	3/8	4716x6	.264	.264	.98	1.45	3/4
1/2	1/2	1/2	4716x8	.378	.391	1.10	1.60	7/8
5/8	5/8	5/8	4716x10	.484	.484	1.31	1.97	1-1/16
3/4	3/4	3/4	4716x12	.609	.609	1.47	2.17	1-3/16
3/4	1	3/4	4716x12x16	.609	.812	1.62	2.32	1-7/16
3/4	3/4	1	4716x12x16x12	.609	.812	1.62	2.35	1-7/16
1	3/4	1	4716x16x12	.812	.609	1.64	2.35	1-7/16
1	1	1	4716x16	.812	.812	1.64	2.35	1-7/16
1-1/4	1-1/4	1-1/4	4716x20	1.046	1.046	1.76	2.45	1-7/8
1-1/2	1-1/2	1-1/2	4716x24	1.313	1.313	1.92	2.59	1-7/8

## Straight Thread O-Ring

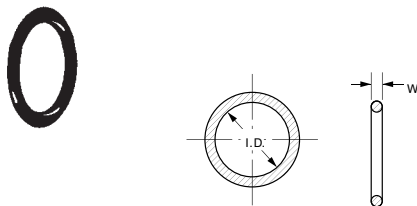

**Material:** Buna-N, 90 Durometer  
**Temperature Range:** -40°F to +250°F  
(-40°C to +121°C)  
Standard O-ring complies with SAE specification J515 Type CH.

Port Size	Catalog Number	W	I.D.
1/16	7629x1	.058 ± .003	.185 ± .005
1/8	7629x2	.064 ± .003	.239 ± .005
3/16	7629x3	.064 ± .003	.301 ± .005
1/4	7629x4	.072 ± .003	.351 ± .005
5/16	7629x5	.072 ± .003	.414 ± .005
3/8	7629x6	.078 ± .003	.468 ± .005
7/16	7629x7	.082 ± .003	.530 ± .005
1/2	7629x8	.087 ± .003	.644 ± .005
5/8	7629x10	.097 ± .003	.755 ± .005
3/4	7629x12	.116 ± .004	.924 ± .006
7/8	7629x14	.116 ± .004	1.048 ± .006
1	7629x16	.116 ± .004	1.171 ± .006
1-1/4	7629x20	.118 ± .004	1.475 ± .010
1-1/2	7629x24	.118 ± .004	1.720 ± .010
2	7629x32	.118 ± .004	2.337 ± .010

STEEL

**Typical Application:** Pressure hydraulic systems.

**Pressure:** Up to 5,000 PSI depending on size.

**Sealing Method:** Metal to metal, 30° cone-NPSM thread on swivel end.

**Material:** Carbon steel, AISI/SAE 12L14.

**Plating:** Zinc, yellow dichromate finish.

**Label Set:** FS-100 (Adhesive)

**9000 Pipe Fittings**

**Pipe Fittings 9000 Series Pressure Rating Chart**

Connection Type	End Size								
	1/8"	1/4"	3/8"	1/2"	3/4"	1"	1-1/4"	1-1/2"	2"
Male Pipe (NPTF)*	5000	5000	4000	3000	2500	2000	1500	1000	1000
Female Pipe (NPTF)*	5000	5000	4000	3000	2500	2000	1500	1500	1000

\* Pressure ratings shown are the pressure ratings for the fitting and are not necessarily the pressure ratings applicable in an assembly with hydraulic hose. The applicable pressure rating for an assembly with hydraulic hose is the lower value specified for the hose and the fitting unless otherwise agreed to by the supplier and user.

**Female Pipe Swivel to Male Pipe**  
(Ref. SAE No. 140130)

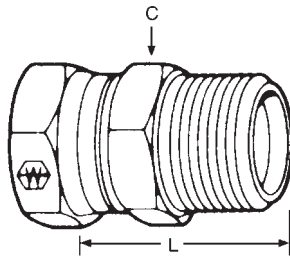

NPSM Swivel Nut	Male Pipe Thread	Catalog Number	Hex C	L
1/8-27	1/8-27	9205x2x2	9/16	.900
1/8-27	1/4-18	9205x2x4	11/16	1.187
1/4-18	1/8-27	9205x4x2	11/16	0.940
1/4-18	1/4-18	9205x4x4	11/16	1.200
1/4-18	3/8-18	9205x4x6	11/16	1.200
1/4-18	1/2-14	9205x4x8	7/8	1.500
3/8-18	1/4-18	9205x6x4	5/8	1.210
3/8-18	3/8-18	9205x6x6	3/4	1.240
3/8-18	1/2-14	9205x6x8	7/8	1.540
1/2-14	3/8-18	9205x8x6	7/8	1.330
1/2-14	1/2-14	9205x8x8	1	1.640
1/2-14	3/4-14	9205x8x12	1-1/4	1.620
3/4-14	1/2-14	9205x12x8	1	1.720
3/4-14	3/4-14	9205x12x12	1-1/4	1.680
3/4-14	1-11-1/2	9205x12x16	1-1/2	1.984
1-11-1/2	3/4-14	9205x16x12	1-1/2	1.800
1-11-1/2	1-11-1/2	9205x16x16	1-1/2	2.010
1-11-1/2	1-1/4-11-1/2	9205x16x20	1-11/16	2.080
1-1/4-11-1/2	1-11-1/2	9205x20x16	1-7/8	2.100
1-1/4-11-1/2	1-1/4-11-1/2	9205x20x20	1-7/8	2.140
1-1/4-11-1/2	1-1/2-11-1/2	9205x20x24	2-1/8	2.187
1-1/2-11-1/2	1-1/4-11-1/2	9205x24x20	2-1/8	2.093
1-1/2-11-1/2	1-1/2-11-1/2	9205x24x24	2-1/8	2.270
2-11-1/2	2-11-1/2	9205x32x32	2-5/8	2.420

**Female 37° SAE Swivel to Male Pipe Adapter**

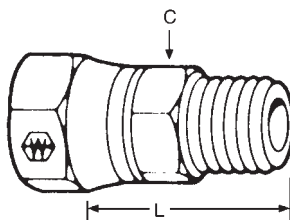

Tube O.D.	Male Pipe Thread	Catalog Number	Hex C	L
1/4	1/4	9100x4x4	9/16	1.130
5/16	1/4	9100x5x4	11/16	1.170
3/8	1/4	9100x6x4	11/16	1.290
3/8	3/8	9100x6x6	11/16	1.290
1/2	3/8	9100x8x6	7/8	1.430
1/2	1/2	9100x8x8	7/8	1.610
5/8	3/8	9100x10x6	1	1.400
5/8	1/2	9100x10x8	1	1.600
3/4	1/2	9100x12x8	1-1/8	1.650
3/4	3/4	9100x12x12	1-1/8	1.650
1	3/4	9100x16x12	1-3/8	1.750
1	1	9100x16x16	1-3/8	1.940
1-1/4	1-1/4	9100x20x20	1-7/8	2.090

NOTE: C and L dimensions subject to change.



# NPSM Female Swivel Adapters

**Steel  
Fittings**

## Female Pipe Swivel to Female Pipe Straight

(Ref. SAE No. 140131)

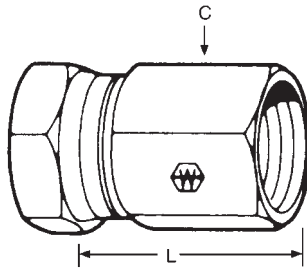

NPSM Swivel Nut	Fem. Pipe Thread	Catalog Number	Hex C	L
1/8-27	1/8-27	9255x2x2	9/16	.880
1/4-18	1/4-18	9255x4x4	11/16	1.170
1/4-18	3/8-18	9255x4x6	7/8	1.312
3/8-18	1/4-18	9255x6x4	11/16	1.250
3/8-18	3/8-18	9255x6x6	7/8	1.310
3/8-18	1/2-14	9255x6x8	1	1.453
1/2-14	3/8-18	9255x8x6	1	1.500
1/2-14	1/2-14	9255x8x8	1	1.500
3/4-14	3/4-14	9255x12x12	1-1/4	1.620
3/4-14	1-11-1/2	9255x12x16	1-1/2	1.906
1-11-1/2	1-11-1/2	9255x16x16	1-1/2	2.000
1-1/4-11-1/2	1-1/4-11-1/2	9255x20x20	1-7/8	2.000
1-1/2-11-1/2	1-1/2-11-1/2	9255x24x24	2-1/8	2.000
2-11-1/2	2-11-1/2	9255x32x32	2-5/8	2.120

## Male Straight Thread to Female Pipe Swivel

(Ref. SAE No. 140157)

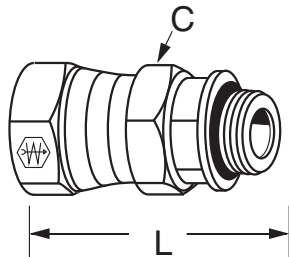

Straight Thread	NPSM Swivel Nut	Catalog Number	Hex C	L
7/16-20	1/4-18	9315x4x4	9/16	.970
7/16-20	3/8-18	9315x4x6	5/8	1.060
1/2-20	1/4-18	9315x5x4	5/8	1.109
9/16-18	1/4-18	9315x6x4	11/16	1.171
9/16-18	3/8-18	9315x6x6	11/16	1.090
9/16-18	1/2-14	9315x6x8	13/16	1.210
3/4-16	1/4-18	9315x8x4	7/8	1.234
3/4-16	3/8-18	9315x8x6	7/8	1.200
3/4-16	1/2-14	9315x8x8	7/8	1.260
3/4-16	3/4-14	9315x8x12	1	1.406
7/8-14	3/8-18	9315x10x6	1	1.375
7/8-14	1/2-14	9315x10x8	1	1.400
7/8-14	3/4-14	9315x10x12	1	1.546
1-1/16-12	1/2-14	9315x12x8	1-1/4	1.453
1-1/16-12	3/4-14	9315x12x12	1-1/4	1.600
1-3/16-12	3/4-14	9315x14x12	1-3/8	1.703
1-5/16-12	3/4-14	9315x16x12	1-1/2	1.734
1-5/16-12	1-11-1/2	9315x16x16	1-1/2	1.710
1-5/8-12	1-11-1/2	9315x20x16	1-7/8	1.828
1-5/8-12	1-1/4-11-1/2	9315x20x20	1-7/8	1.890
1-7/8-12	1-1/2-11-1/2	9315x24x24	2-1/8	1.953
2-1/2-12	2-11-1/2	9315x32x32	2-3/4	2.156

Replacement O-rings page 213.

NOTE: C and L dimensions subject to change.

STEEL

## Female Pipe Swivel to Male Pipe 45° Elbow

(Ref. SAE No. 140330)

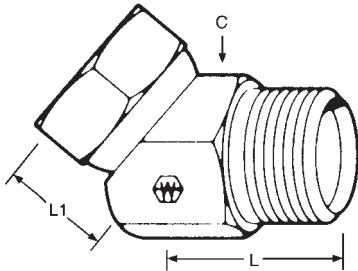

NPSM Swivel Nut	Male Pipe Thread	Catalog Number	Hex		
			C	L	L1
1/8-27	1/8-27	9355x2x2	9/16	.620	.500
1/4-18	1/8-27	9355x4x2	11/16	.660	.470
1/4-18	1/4-18	9355x4x4	11/16	1.020	.670
1/4-18	3/8-18	9355x4x6	7/8	1.060	.620
1/4-18	1/2-14	9355x4x8	1	1.380	.730
3/8-18	1/4-18	9355x6x4	7/8	1.000	.750
3/8-18	3/8-18	9355x6x6	7/8	1.060	.750
3/8-18	1/2-14	9355x6x8	1	1.060	.750
1/2-14	3/8-18	9355x8x6	1	1.310	.910
1/2-14	1/2-14	9355x8x8	1	1.310	.910
1/2-14	3/4-14	9355x8x12	1-1/4	1.31	.910
3/4-14	1/2-14	9355x12x8	1-1/4	1.500	1.000
3/4-14	3/4-14	9355x12x12	1-1/4	1.500	1.000
3/4-14	1-11-1/2	9355x12x16	1-1/2	1.500	1.030
1-11-1/2	3/4-14	9355x16x12	1-1/2	1.310	1.050
1-11-1/2	1-11-1/2	9355x16x16	1-1/2	1.500	1.060
1-11-1/2	1-1/4-11-1/2	9355x16x20	1-7/8	1.800	1.300
1-1/4-11-1/2	1-1/4-11-1/2	9355x20x20	1-7/8	1.750	1.250
1-1/2-11-1/2	1-1/2-11-1/2	9355x24x24	2-1/8	1.940	1.380
2-11-1/2	2-11-1/2	9355x32x32	2-5/8	2.000	1.500

## Female Swivel to Female Pipe 45° Elbow

(Ref. SAE No. 140331)

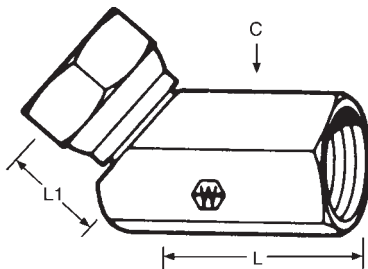

NPSM Swivel Nut	Fem. Pipe Thread	Catalog Number	Hex		
			C	L	L1
1/8-27	1/8-27	9385x2x2	1/2	.620	.500
1/4-18	1/4-18	9385x4x4	11/16	1.020	.670
1/4-18	3/8-18	9385x4x6	7/8	1.062	.625
3/8-18	3/8-18	9385x6x6	7/8	1.060	.750
3/8-18	1/2-14	9385x6x8	1	1.310	.750
1/2-14	1/2-14	9385x8x8	1	1.310	1.270
3/4-14	3/4-14	9385x12x12	1-1/4	1.500	1.000
3/4-14	1-11-1/2	9385x12x16	1-1/2	1.500	1.031
1-11-1/2	1-11-1/2	9385x16x16	1-1/2	1.500	1.000
1-1/4-11-1/2	1-1/4-11-1/2	9385x20x20	1-7/8	1.790	1.250
1-1/2-11-1/2	1-1/2-11-1/2	9385x24x24	2-1/8	1.940	1.380
2-11-1/2	2-11-1/2	9385x32x32	2-5/8	2.000	1.500

## Female 45° Flare Swivel to Male SAE 45° Elbow

(Steel)

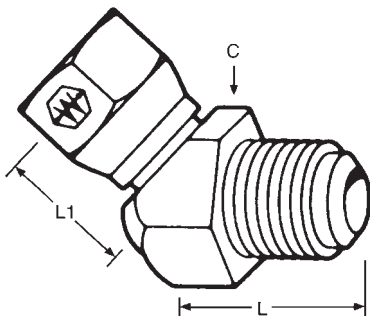

Tube O.D.	Catalog Number	Hex		
		C	L	L1
3/8	9154x6x6	3/4	1.400	.429
1/2	9154x8x8	1	1.760	.598
5/8	9154x10x10	1-1/4	1.920	.645

NOTE: C and L dimensions subject to change.

# NPSM Female Swivel Adapters

**Steel Fittings**

## Male Straight Thread to Female Pipe Swivel 45° Elbow (Ref. SAE No. 140357)

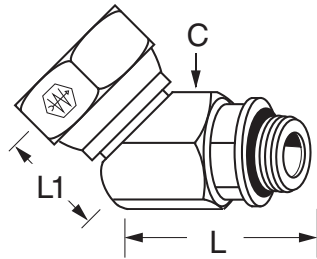

Replacement O-rings page 213.

NPSM Swivel Nut	Straight Thread	Catalog Number	Hex C	L	L1
1/4-18	7/16-20	9365x4x4	11/16	1.062	.656
3/8-18	7/16-20	9365x4x6	7/8	1.062	.656
3/8-18	9/16-18	9365x6x6	7/8	1.062	.703
1/2-14	9/16-18	9365x6x8	1	1.062	.812
3/8-18	3/4-16	9365x8x6	1	1.125	.875
1/2-14	3/4-16	9365x8x8	1	1.125	.812
1/2-14	7/8-14	9365x10x8	1	1.500	.781
3/4-14	1-1/16-12	9365x12x12	1-1/4	1.500	1.046
1-11-1/2	1-5/16-12	9365x16x16	1-1/2	1.625	1.062
1-1/4-11-1/2	1-5/8-12	9365x20x20	1-7/8	1.281	1.171
1-1/2-11-1/2	1-7/8-12	9365x24x24	2-1/8	1.609	1.343

## Female Pipe Swivel to male Pipe 90° Elbow (Ref. SAE No. 140230)

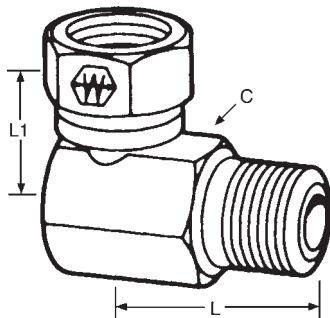

NPSM Swivel Nut	Male Pipe Thread	Catalog Number	Hex C	L	L1
1/8-27	1/8-27	9405x2x2	9/16	.720	.700
1/8-27	1/4-18	9405x2x4	11/16	1.190	.750
1/4-18	1/8-27	9405x4x2	11/16	1.060	.780
1/4-18	1/4-18	9405x4x4	11/16	.980	.750
1/4-18	3/8-18	9405x4x6	11/16	1.090	.810
1/4-18	1/2-14	9405x4x8	1	1.810	.940
3/8-18	1/4-18	9405x6x4	13/16	1.090	.900
3/8-18	3/8-18	9405x6x6	7/8	1.090	.900
3/8-18	1/2-14	9405x6x8	1	1.350	1.020
3/8-18	3/4-14	9405x6x12	1-1/4	2.000	1.120
1/2-14	3/8-18	9405x8x6	1	1.280	1.020
1/2-14	1/2-14	9405x8x8	1	1.350	1.020
1/2-14	3/4-14	9405x8x12	1-1/4	1.490	1.140
1/2-14	1-11-1/2	9405x8x16	1-1/2	2.380	1.250
3/4-14	3/4-14	9405x12x12	1-1/4	1.490	1.200
3/4-14	1-11-1/2	9405x12x16	1-1/2	2.380	1.380
1-11-1/2	3/4-14	9405x16x12	1-1/2	2.190	1.440
1-11-1/2	1-11-1/2	9405x16x16	1-1/2	2.380	1.440
1-11-1/2	1-1/4-11-1/2	9405x16x20	1-7/8	1.578	2.620
1-1/4-11-1/2	1-11 1/2	9405x20x16	1-7/8	2.530	1.660
1-1/4-11-1/2	1-1/4-11-1/2	9405x20x20	1-7/8	2.070	1.630
1-1/4-11-1/2	1-1/2-11-1/2	9405x20x24	2-1/8	2.810	1.780
1-1/2-11-1/2	1-1/2-11-1/2	9405x24x24	2-1/8	2.810	1.750
2-11-1/2	2-11-1/2	9405x32x32	2-5/8	3.120	2.310

## Female Pipe Swivel to Male Pipe 90° Elbow – Long

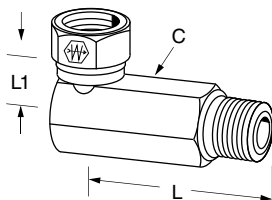

NPSM Swivel Nut	Male Pipe Thread	Catalog Number	Hex C	L	L1
1/8-27	1/8-27	9405X2X2LL	9/16	1.90	.70
1/4-18	1/4-18	9405X4X4LL	11/16	2.57	.75
3/8-18	3/8-18	9405X6X6LL	13/16	3.16	.90
1/2-14	1/2-14	9405X8X8LL	1	3.67	1.02
3/4-14	3/4-14	9405X12X12LL	1-1/4	4.29	1.20
1-11-1/2	1-11-1/2	9405X16X16LL	1-1/2	5.06	1.46

NOTE: C and L dimensions subject to change.

STEEL

## Female Pipe Swivel to Female Pipe 90° Elbow

(Ref. SAE No. 140231)

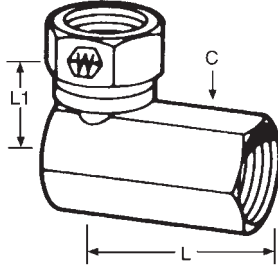

NPSM Swivel Nut	Fem. Pipe Thread	Catalog Number	Hex		
			C	L	L1
1/8-27	1/8-27	9455x2x2	9/16	.640	.700
1/4-18	1/4-18	9455x4x4	11/16	.870	.750
1/4-18	3/8-18	9455x4x6	13/16	1.000	.810
1/4-18	1/2-14	9455x4x8	1	1.250	.940
3/8-18	1/4-18	9455x6x4	13/16	1.000	.900
3/8-18	3/8-18	9455x6x6	13/16	1.000	.900
3/8-18	1/2-14	9455x6x8	1	1.250	1.000
1/2-14	3/8-18	9455x8x6	1	1.220	1.020
1/2-14	1/2-14	9455x8x8	1	1.250	1.000
1/2-14	3/4-14	9455x8x12	1-1/4	1.440	1.120
3/4-14	1/2-14	9455x12x8	1-1/4	1.440	1.250
3/4-14	3/4-14	9455x12x12	1-1/4	1.490	1.200
3/4-14	1-11-1/2	9455x12x16	1-1/2	1.750	1.380
1-11-1/2	3/4-14	9455x16x12	1-1/2	1.750	1.380
1-11-1/2	1-11-1/2	9455x16x16	1-1/2	1.690	1.460
1-1/4-11-1/2	1-1/4-11-1/2	9455x20x20	1-7/8	1.850	1.630
1-1/2-11-1/2	1-1/2-11-1/2	9455x24x24	2-1/8	2.250	1.750
2-11-1/2	2-11-1/2	9455x32x32	2-5/8	2.500	2.310

## 90° Elbow 45° Female Swivel to SAE 45°

(Steel)

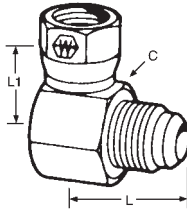

Tube O.D.	Catalog Number	Hex		
		C	L	L1
3/8	9151x6x6	3/4	1.00	.69
1/2	9151x8x8	1	1.25	.99
5/8	9151x10x10	1-1/4	1.44	1.09

## Male Straight Thread to Female Pipe Swivel 90° Elbow

(Ref. SAE No. 140257)

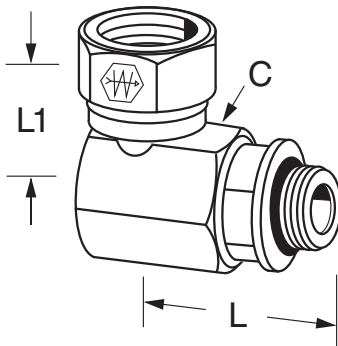

NPSM Swivel Nut	Straight Thread	Catalog Number	Hex		
			C	L	L1
1/4-18	7/16-20	9515x4x4	11/16	1.090	.781
3/8-18	7/16-20	9515x4x6	7/8	1.100	.900
1/4-18	9/16-18	9515x6x4	11/16	1.187	.781
3/8-18	9/16-18	9515x6x6	7/8	1.296	.937
1/2-14	9/16-18	9515x6x8	1	1.484	1.000
3/8-18	3/4-16	9515x8x6	1	1.515	1.000
1/2-14	3/4-16	9515x8x8	1	1.515	1.000
3/4-14	3/4-16	9515x8x12	1-1/4	1.656	1.250
3/8-18	7/8-14	9515x10x6	1	1.640	1.000
1/2-14	7/8-14	9515x10x8	1	1.640	1.025
3/4-14	7/8-14	9515x10x12	1-1/4	1.781	1.250
1/2-14	1-1/16-12	9515x12x8	1-1/4	1.921	1.125
3/4-14	1-1/16-12	9515x12x12	1-1/4	1.921	1.250
3/4-14	1-3/16-12	9515x14x12	1-1/4	1.921	1.250
3/4-14	1-5/16-12	9515x16x12	1-1/2	2.093	1.375
1-11-1/2	1-5/16-12	9515x16x16	1-1/2	2.093	1.390
3/4-14	1-5/8-12	9515x20x12	1-7/8	2.484	1.562
1-1/4-11-1/2	1-5/8-12	9515x20x20	1-7/8	2.484	1.656
1-1/2-11-1/2	1-7/8-12	9515x24x24	2-1/8	2.609	1.734
2-11-1/2	2-1/2-12	9515x32x32	2-5/8	3.250	2.312

Replacement O-rings page 213.

NOTE: C and L dimensions subject to change.

# NPSM Female Swivel Adapters

**Steel Fittings**

## Male Pipe Swivel to Male Pipe Rigid 90° Elbow

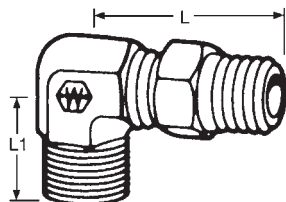

Not for use with liquids over 200°F.

Male Pipe Swivel	Male Pipe	Catalog Number	Hex C	L	L1
1/4-18	1/4-18	9435x4x4	9/16	1.870	1.060
3/8-18	3/8-18	9435x6x6	3/4	1.950	1.220
1/2-14	1/2-14	9435x8x8	7/8	2.250	1.470

## Female Pipe Swivel Tee

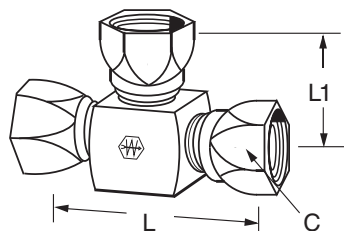

NPSM Swivel Nut	Catalog Number	Across Flats	L	L1	Hex C
1/8-27	9705x2x2x2	1/2	1.406	.660	9/16
1/4-18	9705x4x4x4	11/16	1.720	.780	11/16
3/8-18	9705x6x6x6	7/8	1.720	.940	7/8
1/2-14	9705x8x8x8	1	2.200	1.000	1
3/4-14	9705x12x12x12	1-1/4	2.780	1.250	1-1/4
1-11-1/2	9705x16x16x16	1-1/2	3.060	1.390	1-1/2
1-1/4-11-1/2	9705x20x20x20	1-7/8	3.320	1.660	1-7/8

## Female Pipe Swivel to Male Pipe Branch Tee

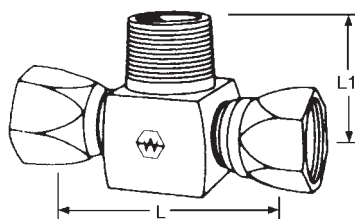

NPSM Swivel Nut	Male Pipe	Catalog Number	Across Flats	L	L1
1/8-27	1/8-27	9406x2x2x2	9/16	1.380	.940
1/4-18	1/4-18	9406x4x4x4	11/16	1.500	1.190
1/4-18	3/8-18	9406x4x4x6	7/8	1.744	1.500
1/4-18	1/2-14	9406x4x4x8	7/8	1.880	1.750
3/8-18	3/8-18	9406x6x6x6	1	1.880	1.750
3/8-18	1/2-14	9406x6x6x8	1	2.000	1.750
1/2-14	1/2-14	9406x8x8x8	1	2.000	1.810
1/2-14	3/4-14	9406x8x8x12	1-1/4	2.250	2.000
3/4-14	3/4-14	9406x12x12x12	1-1/4	2.380	2.000
3/4-14	1-11-1/2	9406x12x12x16	1-1/2	2.756	2.375
1-11-1/2	3/4-14	9406x16x16x12	1-1/2	2.780	2.187
1-11-1/2	1-11-1/2	9406x16x16x16	1-1/2	2.880	2.380
1-1/4-11-1/2	1-1/4-11-1/2	9406x20x20x20	1-7/8	3.240	2.620
1-1/2-11-1/2	1-1/2-11-1/2	9406x24x24x24	2-1/8	3.500	2.810

## Female Pipe Swivel to Female Pipe Branch Tee

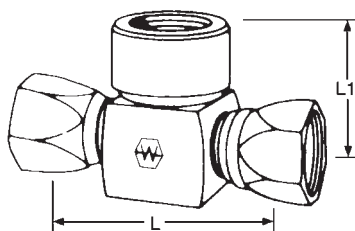

NPSM Swivel Nut	Female Pipe	Catalog Number	Across Flats	L	L1
1/8-27	1/8-27	9456x2x2x2	1/2	1.312	.687
1/4-18	1/4-18	9456x4x4x4	11/16	1.625	.937
1/4-18	3/8-18	9456x4x4x6	7/8	1.744	1.062
3/8-18	3/8-18	9456x6x6x6	7/8	1.874	1.062
3/8-18	1/2-14	9456x6x6x8	1	2.000	1.250
1/2-14	1/2-14	9456x8x8x8	1	2.000	1.250
1/2-14	3/4-14	9456x8x8x12	1-1/4	2.250	1.437
3/4-14	3/4-14	9456x12x12x12	1-1/4	2.500	1.437
3/4-14	1-11-1/2	9456x12x12x16	1-1/2	2.750	1.750
1-11-1/2	1-11-1/2	9456x16x16x16	1-1/2	2.780	1.750
1-1/4-11-1/2	1-1/4-11-1/2	9456x20x20x20	1-7/8	3.312	2.000

NOTE: C and L dimensions subject to change.

STEEL

 Refer to safety information on page 1 & 2.

## Coiled Air Brake Tube Assemblies



Conforms to SAE J844 Type B and SAE J1131.  
 Conforms to DOT FMVSS 571.106.  
 Maximum Working Pressure 150 PSI. Minimum Burst: 950 PSI.  
 Temperature Range -40°F to +200°F.  
 Brass end fittings with spring guards and 1/2" male pipe connections.  
 Spring guards zinc plated for maximum corrosion resistance.  
 Color coding, red for emergency and blue for service, provides you with error free installation.  
 Preassembled for immediate installation.

Catalog Number	Tube O.D.	Male Pipe	Working Length	Pigtail Length
W1206*	1/2	1/2	12'	6"
W1212*	1/2	1/2	12'	12"
W1512*	1/2	1/2	15'	12"

\*Each catalog number contains a coiled red assembly and a coiled blue assembly.

## Gladhand Couplings

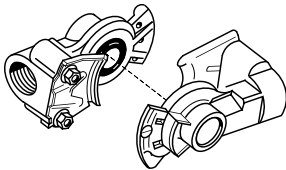

- Die cast aluminum body
- Conforms to SAE J318
- Connects to 1/2" pipe
- Includes seal

### Catalog Number

- W79850 SERVICE (Signal) (Connects only to service)
- W79851 EMERGENCY (Supply line) (Connects only to emergency)
- W76150 UNIVERSAL (Connects to all three styles)

## Gladhand Seal

For use with W79850, W79851, W76150.



### Catalog Number

- W14630

 Refer to safety information on page 1 & 2.

### Vernier Controls

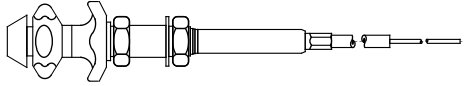

**Catalog Number: 8374**

New advanced styling. Meets or exceeds OEM specifications. Non-Corrosive aircraft aluminum body and stainless steel shaft assures 400 hour salt spray test without corrosion.

A direct replacement for most "Remote Throttle Controls"; Mack Truck 21QB-180 Series, Kenworth K068B Series, Peterbilt 05-1462 Series, Volvo-White 13401 Series, I.H. 34084 Series, Muncie COCL Series BPC VCG Series. Also replaces most Garage and Service Station Wreckers remote control throttles; Earnest Holmes, Dover, etc.

### Turn-To-Lock Controls (T-Locking)

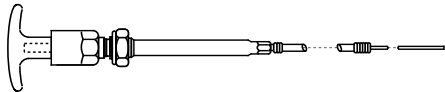

**Catalog Numbers: 8370, 8371**

New positive action control for small to mid-size engine throttles, governors, chokes, fuel shut-offs and more.

Aluminum body assures rust free performance. Patented Acetal Locking bushing guarantees never before possible settings with one third operator effort. Replaces Muncie COCL Series, and BPC R09 Series.

### Power Take Off Controls (Ball Knob)

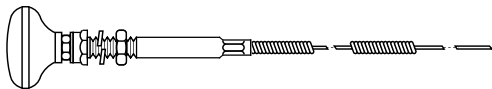

**Catalog Numbers: 8372, 8373**

Utility grade as exact replacement for most P.T.O. Controls.

Features 2" Round Knobs, Galvanized Steel, vinyl covered casing and steel inner wire. All P.T.O. Controls meet or exceed OEM specifications. Replaces BPC R-38DS, R04, R38 and R38D Series, Muncie COKB Series.

 Refer to safety information on page 1 & 2.

## Utility Light Load Controls (Dash)



**Catalog Numbers: 8375, 8376, 8377, 8378**

Universal light load Choke, Fuel-Shutoff, Throttle, Hood, Trunk and more! Controls are designed for most engine applications. Stainless steel inner-wire resists corrosion and assures trouble free operation.

## Throttle Stop



**Catalog Number**

**1548**

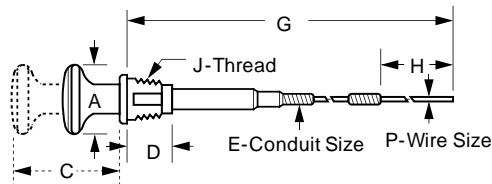

**SPECIFICATION CHART ON WEATHERHEAD "PUSH-PULL" CONTROLS**

Description	Dash				T-Hood	T-Locking		PTO Control		Vernier	Deluxe PTO Control	
	8375	8376	8377	8378	8367	8370	8371	8372	8373	8374	106370	106470
Catalog Number	8375	8376	8377	8378	8367	8370	8371	8372	8373	8374	106370	106470
Length of "G"	84"	84"	84"	60"	180"	126"	186"	81"	165"	120"	192"	300"
Length of Wire "H"	9-3/8"	9-3/8"	9-3/8"	7"	5"	6"	6"	3"	3"	4-1/2"	12"	12"
Knob Type	Round				T-Handle	T-Handle		Round		Round	Round	
Knob Size "A"	1.06"				2"	2"		2"		2"	2"	
Knob Color	Black				Chrome	Chrome		Black		Black	Red	
Knob Material	Plastic				Cast Zinc	Nylon		Plastic		Plastic	Plastic	
Knob Lettering	Choke	Throttle	None	None	None	Lock		None		None	None	
Knob Travel "C"	2-1/2"				2-1/2"	3"		3-1/2"		3-3/8"	4-1/2"	
Thread Size "J"	3/8"-24				3/8"-24	7/16"-20		7/16"-20		3/4"-16	1/2"-20	
Thread Length "D"	1/2"				1/2"	3/4"		1-5/32"		2-1/2"	1-1/8"	
Conduit Size "E"	3/16"				3/16"	3/16"		1/4"		1/4"	3/8"	
Conduit Material & Style	Galvanized Steel				Steel Vinyl Cover	Galvanized Steel	Galvanized Steel		Galvanized Steel	Galvanized Steel	High Carbon	
	Vinyl	Vinyl	Vinyl	Vinyl		Vinyl Covered	Vinyl Covered		Vinyl Covered	Vinyl Covered	Polyethylene Lining & Cover	
Wire Size "P"	.054"				.054"	.054"		.088"		.0625"	.088"	



 Refer to safety information on page 1 & 2.



### T-570-1 • Ermeto-Quick Set™ Preset Machine

The Ermeto-Quick Set Machine is ideal for bulk assemblies. It has a positive-stop action, which guarantees uniform repeatability, and a hand pump operation which yields quick cycle time, reducing assembly time. The T-570 is an easy tool to use that will save you time and money.

**T-570 Package includes:**

<b>T-460-2</b>	Hand Pump (10,000 PSI)		
<b>T-450-3</b>	Quick Disconnect Hose Assembly		
<b>T-570-1</b>	Ermeto® Preset Machine		
<b>T-570-4</b>	Preset Die	<b>T-571-4</b>	Tube Support
<b>T-570-6</b>	Preset Die	<b>T-571-6</b>	Tube Support
<b>T-570-8</b>	Preset Die	<b>T-571-8</b>	Tube Support
<b>T-570-12</b>	Preset Die	<b>T-571-12</b>	Tube Support
<b>T-570-16</b>	Preset Die	<b>T-571-16</b>	Tube Support

-20, -24, and -32 sizes also available.



### Metric Flareless Hand Presetting Tools

Presetting tools provide a more accurate and positive leak-proof method of coupling flareless fittings. Presetting the steel sleeves prior to fitting assembly will permit the maximum high performance obtainable with flareless fittings. These tools are available for both the Light (DIN 3901/3902L) and Heavy (DIN 3901/3902S) flareless series.

Light Series 3901/3902L			Heavy Series 3901/3902S		
Catalog Number	Tube O.D. (mm)	Thread Size	Catalog Number	Tube O.D. (mm)	Thread Size
<b>TL7008</b>	8	M14x1.5	<b>TH7008</b>	8	M16x1.5
<b>TL7010</b>	10	M16x1.5	<b>TH7010</b>	10	M18x1.5
<b>TL7012</b>	12	M18x1.5	<b>TH7012</b>	12	M20x1.5
<b>TL7015</b>	15	M22x1.5	<b>TH7014</b>	14	M22x1.5
<b>TL7018</b>	18	M26x1.5	<b>TH7016</b>	16	M24x1.5
<b>TL7022</b>	22	M30x2.0	<b>TH7020</b>	20	M30x2.0
<b>TL7028</b>	28	M36x2.0	<b>TH7025</b>	25	M36x2.0
			<b>TH7030</b>	30	M42x2.0



### Ermeto® Hand Presetting Tools 7000 Series

Presetting tools provide a more accurate and positive leak-proof method of coupling flareless fittings. Presetting steel Ermeto® sleeves on tubing prior to fitting assembly will permit the maximum high performance obtainable with flareless fittings. Due to possible thread galling, the use of presetting tools is required when assembling stainless steel fittings.

Catalog Number	Tube O.D. (Inches)	Thread Size	Catalog Number	Tube O.D. (Inches)	Thread Size
<b>T-7002</b>	1/8	5/16-24	<b>T-7012</b>	3/4	1-1/16-12
<b>T-7003</b>	3/16	3/8-24	<b>T-7014</b>	7/8	1-3/16-12
<b>T-7004</b>	1/4	7/16-20	<b>T-7016</b>	1	1-5/16-12
<b>T-7005</b>	5/16	1/2-20	<b>T-7020</b>	1-1/4	1-5/8-12
<b>T-7006</b>	3/8	9/16-18	<b>T-7024</b>	1-1/2	1-7/8-12
<b>T-7008</b>	1/2	3/4-16	<b>T-7032</b>	2	2-1/2-12
<b>T-7010</b>	5/8	7/8-14			

RELATED PROD

 Refer to safety information on page 1 & 2.

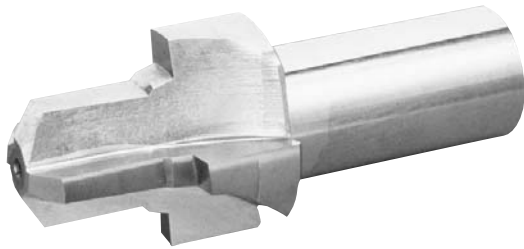
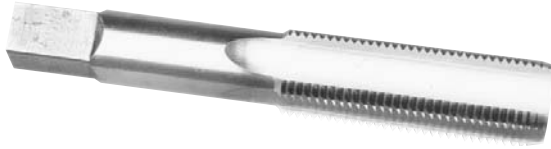

## SAE Straight Thread O-Ring Boss Tapping and Counterboring Tools

These Weatherhead precision counterborer and tap tools are available in the full range of sizes. They provide the correct SAE contour and UNF-2B threads for proper containment of Weatherhead Flareless '7000' Series Ermeto® and Weatherhead Flare-Twin® straight-thread o-ring tube fittings.

Thread Tap Catalog No.	UNF-2B Thread Size of Thread Tap	Drill Size	For Fitting Size	For Tube O.D.	Counter-Borer Catalog No.
T-5002	5/16-24	I	2	1/8	T-5102
T-5003	3/8-24	O	3	3/16	T-5103
T-5004	7/16-20	W	4	1/4	T-5104
T-5005	1/2-20	29/64	5	5/16	T-5105
T-5006	9/16-18	1/2	6	3/8	T-5106
T-5008	3/4-16	11/16	8	1/2	T-5108
T-5010	7/8-14	51/64	10	5/8	T-5110
T-5012	1-1/16-12	31/32	12	3/4	T-5112
T-5014	1-3/16-12	1-3/32	14	7/8	T-5114
T-5016	1-5/16-12	1-7/32	16	1	T-5116
T-5020	1-5/8-12	1-17/32	20	1 1/4	T-5120
T-5024	1-7/8-12	1-25/32	24	1 1/2	T-5124
T-5032*	2-1/2-12	2-27/64	32	2	T-5132*

\*Special order only.



## RG-24 • Hydraulic O-Ring Assortment

Weatherhead's RG-24 is your solution to storing a useful inventory of hydraulic o-rings. This kit contains o-rings for Weatherhead's straight thread and FOR-SEAL® tube fitting applications as well as popular (code 61) split flange hydraulic applications. The RG-24 comes enclosed in a handy steel case with a carrying handle. Consider an RG-24 for an over-the-counter sales merchandiser or keep one in your equipment shop or maintenance trailer to prepare for those critical "got-to-have-it" applications.

Twenty-four individual compartments keep your hydraulic o-ring inventory separated by part number, and labelled illustrations on the inside of the assortment prevent the mix-up of o-rings. Compact, organized and reasonably priced, if you specialize in hydraulic applications which call for o-rings – we've got your number – RG-24.

### RG-24 • O-Ring Assortment Contents

Part Number	Split Flange Quantity	Part Number	FOR-SEAL® Quantity	Part Number	Straight Thr. Quantity
8x252	12	4629x4	12	7629x4	12
12x252	12	4629x6	12	7629x5	12
16x252	12	4629x8	12	7629x6	12
20x252	12	4629x10	12	7629x8	12
24x252	12	4629x12	12	7629x10	12
32x252	12	4629x16	12	7629x12	12
		4629x20	12	7629x16	12
		4629x24	12	7629x20	12
				7629x24	12
				7629x32	12

O-rings conform to SAE J515 Type CH.

 Refer to safety information on page 1 & 2.



### TA-1002 • Thread Measuring Kit

Measuring tube and pipe fitting threads can be a most difficult task if not completely understood. Tools needed include a thread pitch gauge, calipers and seat angle gauges. To aid you, Weatherhead has a kit to fit your needs, the TA-1002 thread measuring kit.

#### This handy kit includes:

- Thread Pitch Gauge (American and metric)
- Inside/Outside Caliper (inches and millimeters)
- 2 Seat Angle Gauges (37°/45° and a 12°/30°)
- 24-Page International Measuring and Identification Guide and Instruction Booklet
- Carrying Case for Easy and Convenient Storage



### TA-1004 • Metric Thread Identification Kit

Contained in a durable steel carrying case, TA-1004 will help you with identification of metric, British pipe and JIS thread configurations. Identification pieces are configured for 20 metric and 8 British pipe sizes, an increase of three metric sizes compared to the TA-1003.

#### This handy kit includes:

- Steel Carrying Case
- Stainless Steel Caliper
- Metric and British Thread Pitch Gauges
- British Thread Measuring Templates (4 measuring 8 sizes) made of durable aircraft grade aluminum.
- Metric Thread Measuring Templates (10 measuring 20 sizes) made of durable aircraft grade aluminum.
- Kit Content Identification Chart

RELATED PROD

 Refer to safety information on page 1 & 2.



## Rapid Wrenches

The Rapid Wrench is a heavy-duty, high quality wrench that ratchets for quick installation and removal of tube fittings and hose ends. These wrenches have jaws that snap open and close completely around the fitting giving 6-point contact. Needing only 30° of rotation to ratchet, they allow easy access to tight locations. Available individually or in a set with pouch, these wrenches are a welcome addition to any tool box.

- T-139** 7-Piece Set with Pouch (1/2" through 7/8")
- T-139P** Pouch for 7-Piece Set
- T-152** 11-Piece Set with Pouch
- T-152P** Pouch for 11-Piece Set

Catalog Number	Wrench Hex Size	Catalog Number	Wrench Hex Size
<b>T-140</b>	3/16"	<b>T-145</b>	11/16"
<b>T-141</b>	7/16"	<b>T-146</b>	3/4"
<b>T-142</b>	1/2"	<b>T-147</b>	13/16"
<b>T-143</b>	9/16"	<b>T-148</b>	7/8"
<b>T-144</b>	5/8"	<b>T-149</b>	15/16"
		<b>T-151</b>	1"



## T-150 • Utility Tube Cutter

Need to cut stainless steel tubing? This cutting tool is for you. It features an enclosed feed screw to eliminate clogging and jamming. Grooved rolls for close to flare cuts and a fold away reamer.

**Capacity:** 1/8" to 1-1/8" O.D. Cuts hard and soft copper, aluminum, brass, carbon steel and stainless steel tubing.

**Spare Parts:** **T-1422R** Replacement Cutting Wheel

 **CAUTION:** Sharp blade! Keep hands and fingers away from cutting surface!



## T-1430 • Inner-Outer Reamer

Reams both inside and outside edges of tube with three hollow ground tool steel cutters. Fluted body is shaped to fit comfortably in palm of hand.

**Capacity:** 3/16" to 1-1/2" O.D. Reams copper, brass, aluminum and other tubing.

 **CAUTION:** Sharp blade! Keep hands and fingers away from cutting surface!

 Refer to safety information on page 1 & 2.



### T-1037 • Knife

An inexpensive, reliable knife useful in splitting twin-line hoses quickly and easily.

**Replacement Blade:** T-1037B

**Replacement Handle:** T-1037H



### T-135 • Plastic Tube and Hose Cutter

An economical alternative to quality tube and hose cutting. This versatile tool is lightweight and durable for long service life.

**Replacement Blade:** T-135B

**Replacement Blade for T-125:** T-125B

**Capacity:** Up to 1" hose I.D.

**NOTE:** Not for use with wire-reinforced hose.



### T-138 • Hose and Tube Cutter

One hand operation for quick, clean cuts through plastic or nylon compound tubing and solid or fiber-reinforced hose up to 1-1/2" O.D.

- Any wireless hose or tubing.
- Power steering hose (H324)
- Air Conditioning hose (H757)
- Air brake hose (H338)
- Air system nylon tubing (NT100)
- Thermoplastic hose (H435, H436, H335, and H336)
- Low pressure plastic tubing (PT200, PT230, PT240)

**Replacement Blade:** T-138B

**NOTE:** Not for use with wire-reinforced hose.



### T-191 • Plastic Tube and Hose Cutter

A tool designed to be small, only 2-7/8" long. The versatile Weatherhead T-191 offers quick and clean square cuts on 1/16" to 1/2" O.D. plastic tubing and non-wire reinforced hose. The T-191 can be either bench or wall mounted and offers the safety of closing automatically when not in use.

**Spare Parts:** T-191B Replacement Blade (one per package)

 Refer to safety information on page 1 & 2.



**A**



**B**



**C**

## LEVER TYPE TUBE BENDERS

Each tool bends one size. Openside type. Handy in a tight spot. Makes precision short radius bends up to 180° with minimum effort. Keeps tube round, no marks or scrapes, shows bend degree. Unique extra strong hook grips tubing securely.

Catalog Number	Tubing (O.D.)	Nominal Size	Radius to Center of Tube	Weight Each	Type
T-372	1/8	—	3/8	8 ozs.	A
T-373	3/16	—	7/16	9 ozs.	A
T-374	1/4	1/8	9/16	12 ozs.	B
T-375	5/16	—	11/16	1 lb. 4 ozs.	B
T-376	3/8	—	15/16	1 lb. 12 ozs.	B
T-378	1/2	3/8	1-1/2	3 lb. 8 ozs.	B
T-3710*	5/8	1/2	2-1/4	10 lbs.	C
T-3712*	3/4	5/8	3	10 lbs. 8 ozs.	C
T-3716*	1	—	3-1/2	10 lbs. 8 ozs.	C

\* Will bend annealed copper and aluminum tubing only.

**Capacity:** Individual tools for bending eight sizes from 1/8" to 3/4" O.D. tubing. Will bend annealed copper, annealed-steel (inc. JIC), stainless steel and all soft tubing.



## SPRING TUBE BENDERS

Low cost, tube bending spring operates perfectly in hand bending copper, aluminum and other thin-walled tubing. Bends are true with minimum tubewall collapsing. Belled at one end to facilitate removal. Bright-plated spring wire finish.

Catalog Number	Tubing (O.D.) (Inches)	Length (Inches)	Weight
T-104	1/4	10	4 ozs.
T-105	5/16	10	4 ozs.
T-106	3/8	10	5 ozs.
T-107	7/16	12	7 ozs.
T-108	1/2	12	8 ozs.
T-1010	5/8	12	10 ozs.
<b>SETS</b>			
T-100	1/4, 3/8, 1/2, 5/8	10 & 12	1-1/2 lbs.
T-200	1/4, 5/16, 3/8, 1/2	10 & 12	1-1/4 lbs.

 Refer to safety information on page 1 & 2.



### T-345K • Tube Cutting and Flaring Kit

Tube flaring and cutting has just become a little easier with the convenient T-345K Tube Flaring and Cutting Kit.

This kit features a quality-made Double Flaring Tool offering accurate single flares between 3/16" and 5/8" O.D. tubing. Double flares between 3/16" and 2/2" O.D. tubing. Check these features:

- Hardened, smooth cone for fast, accurate 45° flares.
- Single and double flare capability.
- Clamp screw for easy clamping and removal of tubes.
- Flaring Bar installed from either side of yoke.
- Flares soft copper, brass, aluminum and mild steel (JIC and Bundy) tubing.

T-345K Components can be ordered separately:

**T-345** 45° Flaring Tool, Double Flare Adapters and Plastic Box

**T-150** 1/8" to 1-1/8" Tube Cutter

**T-1422R** T-150 Spare Cutting Wheel

#### Double Flare Adapters:

Catalog Number	Tube O.D.
T-346x3	3/16"
T-346x4	1/4"
T-346x5	5/16"
T-346x6	3/8"
T-346x8	1/2"

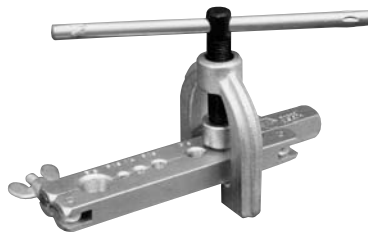

### T-1022 • Flaring Tool (45°)

Economical, fast operating tool. Quick slip-on aluminum alloy yoke. Easy operating, swivel-type, hard chrome finished cone assures smooth flares.

Yoke slips down over top of bar and locks into position with a single turn.

**Flaring Capacity:** 3/16", 1/4", 5/16", 3/8", 7/16", 1/2", and 5/8" O.D. Forms 45° flares in soft copper, aluminum and brass.

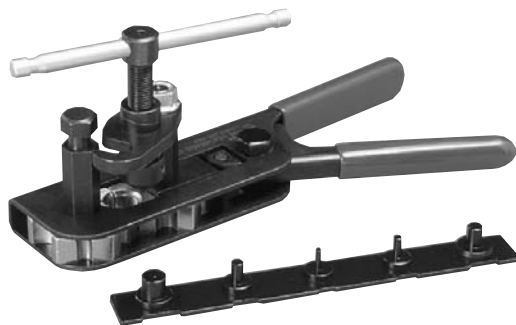

### T-220 • Double Flaring Tool (45°)

This new style tool makes single or double flaring easier and quicker than ever. Cam action provides positive, non-slip grip on the tubing with just a squeeze of the handle. Double flaring bar also serves as gauge for correct tubing height to insure perfect flares.

**Flaring Capacity:** 3/16", 1/4", 5/16", 3/8", 1/2" and 5/8" O.D. for single flares, and up to 1/2" O.D. for double flares. Can be used with copper, aluminum, brass, bundyweld and steel tubing.

**Weight:** 2 lbs.

**T-220** Components can be ordered separately

**T-210** Tool for single flaring only

**T-221** Double Flaring Bar only.

**Flaring Capacity:** 3/16", 1/4", 5/16", 3/8" and 1/2"



### T-1290 • Segmented Flaring Tool (37°)

Hard chrome finished cone makes exceptionally smooth flares and minimizes amount of effort needed. Forged steel yoke for maximum strength. Sliding die blocks lock in place by lever clamp action.

**Flaring Capacity:** 3/16", 1/4", 5/16", 3/8", 1/2" and 5/8" O.D. Forms 37° SAE flares in soft copper, aluminum, brass and bundyweld tubing.

**Weight:** 1 lb., 11 oz.

 Refer to safety information on page 1 & 2.

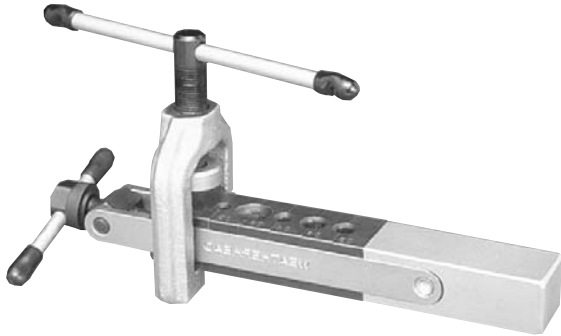

## T-1295 • Heavy-Duty Segmented Flaring Tool (37°)

Ideal for use where considerable number of 37° flares in stainless steel tubing must be made. Built to withstand continuous rugged service. Ball thrust mechanism reduces effort required. Hardened tool steel die features non-slip grip of tubing – even after repetitive flaring. Bar has vise extension.

**Flaring Capacity:** 1/8", 3/16", 1/4", 5/16", 3/8", and 1/2", O.D. tubing. Forms 37° SAE flares in annealed stainless steel (MIL-T-6845 or AMS-5566), cold drawn stainless steel, and annealed copper, brass, steel or aluminum.

**Weight:** 3 lbs.



## T-562 • Circa Torch

This braze tool from Weatherhead provides an excellent way to braze FOR-SEAL® fittings. Heat is evenly distributed among six flame ports creating a fast, convenient way to make tube assemblies.

 **WARNING:** Torch only to be used with acetylene!

 **WARNING:** Must be used in a well ventilated area!



# Brazing Tools & Label Sets

**Related Products**

 Refer to safety information on page 1 & 2.



 **WARNING:** Must be used in a well ventilated area!

## T-560 • MAGNATORCH BRAZING MACHINE

The new Magnatorch Brazing Machine from Weatherhead is perfect for making large numbers of FOR-SEAL® Tube Fitting Assemblies. By providing 360 degree induction heating, the brazing process is fast, clean and flameless. A heavy duty cart is also provided with table top work area, vise, and storage drawer to make up a complete brazing station. The T-560 includes one each of the following:

Catalog Number	Qty.	Description
T-560-1	1	Magnatorch Power Source
T-560-2	1	Magnatorch Water System
T-560-3	1	Magnatorch Induction Torch
T-560-4	1	Magnatorch Power Cables
T-560-5	1	Magnatorch Heating Coil #1 (1-1/4 I.D.)
T-560-6	1	Magnatorch Heating Coil #2 (1-5/16 I.D.)
T-560-7	1	Magnatorch Heating Coil #3 (2-1/4 I.D.)
T-560-8	1	Magnatorch Torch Cart

## LABEL SETS

for FC-16X, C-63X and C-632X Cabinets



Full assortment available. Each label contains catalog number, illustration, size data and color coding for quick, positive identification of parts. Labels slide easily into slots on drawers and dividers.

Catalog Number	Description
CL-16-1	Standard Brass Fittings for FC-16X cabinet.
CL-16-2	Air brake fittings for copper tubing. Use with FC-16X cabinet.
CL-16-3	Air brake fittings for nylon tubing. Use with FC-16X cabinet.
CL-434	Fuel Line Hose Fittings (series 057B).
CL-490	Standard brass fittings, drain and shut-off cocks includes Compression, SAE, Inverted and Pipe, and series 057B fuel line hose fittings.
CL-491	Air brake fittings for copper tubing.
CL-492	Hydraulic brake fittings.
CL-493	Barb-Tite® hose ends.
CL-494	Master Set - contains one each of CL-490, CL-491, CL-492, CL-493.
CL-496	Mini-Barb® fittings.
CL-497	Air brake fittings for nylon tubing.
CL-498	Polyline® fittings.
CL-499	Push>Connect
CL-500	Selfalign®
CL-501	Plastic Fittings
CL-502	Metric Adapters
CL-503	QCAB® Fittings

## SELF-ADHESIVE LABEL SETS

for FH-15X and C-15X Cabinets



Labels are printed on self-adhesive stock for quick application. Each label contains an illustration of the part along with the catalog number and size information.

Catalog Number	Description
FS-100	Swivel Adapters
FS-200	SAE Steel Adapters
FS-300	Split Flange Adapters, Split Flange Kits, O-Ring Port Adapters
FS-500	Barb-Tite® Hose Ends
FS-501	BL-456 Assortment Label Set
FS-800	Air brake fitting for copper tubing and 338 "B" Series Hose Ends
FS-900	Air brake fittings for nylon tubing
FS-1000	Mini-Barb® fittings
FS-1600	Flareless Ermeto® 7000 Series
FS-2000	Steel pipe fittings
FS-2100	Polyline® fittings
FS-2400	FOR-SEAL® Adapters
FS-3300	QCAB® Fittings
SH-53	Weatherhead envelope 6" x 4-1/2" (Qty 500)
W-8022	Standard brass fittings and drain-shut-off valves

## PLASTIC BAGS



Weatherhead heavy-duty plastic bags for Weatherhead fittings come in sizes 5"x6", 6"x10", and 8"x12". The bags include convenient spaces for labeling.

Catalog Number	Description
5x6 PB	Plastic Bag
6x10 PB	Plastic Bag
8x12 PB	Plastic Bag

RELATED PROD





### FC-16X • STOCK CABINET

Contains 16 clear plastic drawers that can be divided into two or three sections. Illustrated color labels are available to provide instant identification of drawer contents.

**Size:** 16-1/8" wide x 11-3/4" high x 9" deep  
**Weight:** 13 lbs.  
**Drawers:** PD-49  
**Dividers:** PD-75 set  
 (14/set)



### C-15X • STOCK CABINET

Contains 15 extra large white drawers for those large, difficult to store fittings and valves. The 15 drawers may be divided into two or three sections to suit your particular needs.

**Size:** 30-1/4" Wide x 14-3/8" Deep x 13-5/8" High  
**Weight:** 45 lbs.  
**Drawers:** CD-15  
**Dividers:** CD-15D  
 (30 per set)



### FH-15X • STOCK CABINET

Here is the ideal way to organize your inventory of hose ends and adapters. Stock it anyway you want — to fit your particular needs. It can be used for field service, or as a jobber display and stock cabinet. The rugged FH-15X cabinet contains 15 plastic drawers for stocking hose ends and adapters.

**Size:** 30-1/4" Wide x 13-5/8" High x 14-3/8" Deep  
**Weight:** 45 lbs.  
**Drawers:** PD-95  
**Dividers:** PD-15  
 (30 per set)



### C-63X • STOCK CABINET

A cabinet containing 63 drawers that can be divided into two or three sections. The bright color and attractive design make the C-63X stock cabinet a nice addition to any store front.

**Used with assortments:** AB-1400, CA-631, and CA-632.

**Size:** 30-1/4" wide x 25" high x 9-1/4" deep  
**Weight:** 61 lbs.  
**Drawers:** PD-49  
**Dividers:** PD-75 Set  
 (14/set)



### C-632X • Cabinet

This Weatherhead Brass Fittings Cabinet, C-632X, is a space saving, efficient, easy to use addition to the modern store with lobby type sales area. The C-632X requires a minimum of space but does a maximum job merchandising the wide variety of fittings in the 126 clear, wide, plastic drawers. An additional 15 large, high impact plastic drawers located in the bottom section provide ample space for those large or heavy special fittings you may be stocking.

Restocking is easy when you start at the bottom and pull drawers for an order check. Leave drawers extended that are low in stock. Now start at top, note quantity needed and return drawers to original position after order is written using standard box quantities listed on labels. Plastic dividers are provided to section drawers for future expansion when new or additional part numbers are needed.

Display this attractive cabinet with a recommended stock of fittings in your lobby and watch your brass fitting sales increase as the C-632X silently and quickly services your customers. Create those impulse sales that make your business and profits grow!

For complete [CA-632](#) assortment, see page 234.

#### CONTENTS

Catalog Number	Description
<a href="#">C-15X</a>	15 Drawer Cabinet
<a href="#">C-63X</a>	63 Drawer Cabinet
<a href="#">CB-63X</a>	Cabinet Base
<a href="#">CD-15</a>	Plastic Drawer for C-15X
<a href="#">C-632X</a>	2—C-63X, 1—C-15X, 1—CB-63X
<a href="#">PD-49</a>	Drawers for C-63X
<a href="#">PD-75 set</a>	Dividers for drawers (14 count)

**Size:** 68-1/2" high, 30" wide, 15" deep.

**Weight:** 167 lbs.

## CA-632 • FITTINGS ASSORTMENT

The CA-632 assortment combines a colorful, attractive lobby display unit and an assortment of fast moving brass fittings with coverage for most any application. This space saving assortment includes color coded, illustrated, labels for quick identification by customers of standard fittings, as well as fuel line, carburetion, metric and domestic hydraulic brake and thermoplastic brass fittings in 240 configurations and sizes. Be a supplier to auto dealers, brake specialists, RV shops, plant maintenance shops, truck and bus fleets, contractors, marinas, loggers, shipyards, fishing fleets, farmers and self installers for their brass fitting requirements. Contents of this assortment may vary as new fittings are introduced and stock fittings change in popularity.

Contents Only: [CA-632CO](#)

### CA-632 Contents

Catalog Number	Quantity	Catalog Number	Quantity	Catalog Number	Quantity	Catalog Number	Quantity
41x3	10	69x2	10	2030x8	5	3600x4	5
41x4	10	69x3	10	3129x2	5	3700x2	10
41x5	10	69x4	10	3150x2	10	3700x4	5
41x6	10	69x4x4	10	3150x4	10	3700x6	5
41x8	5	69x5	10	3151x2	10	3750x2	5
42x4	5	69x5x4	10	3151x4	10	3750x4	5
42x6	5	69x6	10	3151x6	10	6100x2	10
48x3	10	69x6x2	5	3151x8	5	6100x3	10
48x4	10	69x6x6	5	3152x2	10	6100x4	10
48x4x4	10	69x8	5	3152x4	10	6200x2	10
48x5	10	100x3	10	3152x6	10	6200x3	10
48x5x4	10	100x4	10	3152x8	5	6200x4	10
48x6	10	100x5	10	3152x12	2	6202	10
48x6x2	5	100x6	10	3200x2	10	6660	5
48x6x6	5	105x2	10	3200x4	5	6749	1
48x8	5	105x3	20	3200x4x2	10	6809	5
49x4	10	105x4	20	3200x6x4	5	6829	5
49x4x4	5	105x5	20	3200x8x6	5	6892	5
49x5	10	105x6	10	3220x4x2	20	7818	5
49x5x4	5	131x3	10	3220x6x2	10	7828	5
49x6	10	131x4	10	3220x6x4	10	7829	5
49x8	5	131x5	10	3220x8x2	5	7896x3	5
60x2	50	131x6	10	3220x8x4	10	7896x4	5
60x3	50	135	10	3220x8x6	5	7904	5
60x4	50	140	5	3220x12x6	2	7906	5
60x5	50	145	10	3220x12x8	2	7908	2
60x6	50	202x3	10	3300x2	10	7914	2
60x8	20	202x4	10	3300x4	10	7934A	5
60x10	10	202x4x4	10	3300x4x2	10	7935	5
61x2	10	202x5	10	3300x6	5	7936	5
61x3	20	202x5x4	10	3300x6x4	5	7937	5
61x4	20	202x6	10	3300x8	5	7940	5
61x5	20	202x6x2	5	3300x8x6	5	7941	5
61x6	10	252x3	10	3325x2	10	05703B-102	5
61x8	10	252x4	10	3325x4	10	05704B-102	10
62x2	10	270	5	3325x4x2	5	05704B-104	5
62x3	10	302x3	10	3325x6	5	05704B-C02	5
62x4	10	302x4	10	3325x6x4	5	05705B-102	10
62x5	10	302x5	10	3326x2	10	05705B-104	5
62x6	10	302x6	5	3326x4	10	05705B-C02	10
62x8	5	402x3	10	3326x6	10	05705B-C04	10
62x10	1	402x4	10	3326x8	5	05705B-1560	10
64x4	5	402x4x4	5	3327x2	10	05705B-1561	10
64x6	5	402x5	10	3327x4	5	05706B-102	10
66x2	10	402x5x4	10	3328x2	10	05706B-104	10
66x3	10	402x6	10	3328x4	5	05706B-106	5
66x4	10	1442	5	3328x6	5	05706B-C02	5
66x6	5	1443	5	3350x2	5	05706B-C04	5
68x2	10	1514	5	3350x4	5	05706B-1568	5
68x3	10	1538	10	3350x6	5	05706B-1570	5
68x4	10	1548	10	3400x2	10	C-632X	1
68x4x4	10	1552x9	10	3400x4	10	CL-490	1
68x5	10	1552x10	10	3400x6	5		
68x5x4	10	2030x4	10	3400x8	5		
68x6	10	2030x44	10	3500x2	10		
68x6x2	10	2030x5	10	3500x4	10		
68x6x6	5	2030x6	10	3600x2	5		
68x8	5						



### CA-631 • BRASS FITTINGS ASSORTMENT

This merchandiser will help you organize your brass fittings in an attractive 63 drawer cabinet. It includes a stock of the 100 fastest moving brass fittings to better service your customers. To expand, divide the clear, easy to inventory, super sized plastic drawers in half or thirds with plastic dividers provided. Illustrated, color-coded labels in a wide range of fitting types provide instant identification of drawer contents. Your lobby and sales will be improved with this modern display set up on a gondola or shelf. Contents may vary as new numbers become available and popularity changes.

Contents Only: [CA-631CO](#)

Cabinet Only: [C-63X](#)

#### CA-631 Contents

Catalog Number	Qty.	Catalog Number	Qty.	Catalog Number	Qty.	Catalog Number	Qty.	Catalog Number	Qty.	Catalog Number	Qty.
41x4	10	61x4	10	69x6	10	302x5	10	3200x6x4	5	3327x2	5
41x6	10	61x5	10	105x3	20	302x6	5	3220x4x2	20	3327x4	5
48x4	10	61x6	10	105x4	20	402x4	10	3220x6x2	10	3328x2	5
48x4x4	10	62x2	10	105x5	20	402x5	10	3220x6x4	10	3328x4	5
48x5	10	62x3	10	105x6	10	402x6	10	3220x8x2	5	3350x2	5
48x5x4	10	62x4	10	131x3	10	3150x2	5	3220x8x4	10	3350x4	5
48x6	10	62x5	10	131x4	10	3150x4	5	3220x8x6	5	3400x2	10
48x6x6	5	62x6	10	131x5	10	3151x2	10	3300x2	10	3400x4	10
49x4	5	68x2	10	131x6	10	3151x4	10	3300x4	10	3400x6	5
49x6	10	68x3	10	202x3	10	3151x6	10	3300x4x2	10	3700x2	10
60x2	50	68x4	10	202x4	10	3151x8	10	3300x6	5	3700x4	5
60x3	50	68x4x4	10	202x4x4	10	3152x2	10	3300x6x4	5	3750x4	5
60x4	50	68x5	10	202x5	10	3152x4	10	3325x2	10	3750x6	2
60x5	50	68x5x4	10	202x5x4	10	3152x6	10	3325x4	10	135	10
60x6	50	68x6	10	202x6	5	3152x8	5	3326x2	10	145	10
61x2	10	68x6x2	10	302x3	10	3200x2	5	3326x4	10	C-63X	1
61x3	10	69x4	10	302x4	10	3200x4x2	10	3326x6	10	CL-490	1



### FC-161 • BRASS FITTINGS ASSORTMENT

The FC-161 brass fitting assortment contains the fastest moving SAE 45° Flare, Inverted Flare, Compression and Pipe catalog numbers to give your customers maximum coverage at a low cost. Nuts, sleeves and unions make an ideal stock for any small repair, auto, boat, lawn mower, or fixit shop. Cabinet includes 16 clear plastic drawers and color-coded labels for easy identification. The FC-161 fits on any shelf and goes to work immediately.

Cabinet Only: [FC-16X](#)

#### FC-161 Contents

Catalog Number	Qty.	Catalog Number	Qty.	Catalog Number	Qty.	Catalog Number	Qty.	Catalog Number	Qty.	Catalog Number	Qty.
41x4	2	60x3	20	62x4	5	69x6	2	302x4	5	3220x6x4	5
41x5	2	60x4	20	62x5	5	105x3	10	302x5	2	3300x2	5
41x6	2	60x5	20	62x6	5	105x4	10	402x3	2	3300x4	2
48x4	2	60x6	20	68x4	2	105x5	10	402x4	2	3400x2	5
48x5	2	61x3	10	68x5	2	105x6	5	402x5	2	3400x4	5
48x6	2	61x4	10	68x6	2	202x4	2	3151x2	2	145	5
49x4	2	61x5	10	69x4	2	202x5	2	3151x4	2	FC-16X	1
49x5	2	61x6	5	69x5	2	302x3	5	3220x4x2	5	CL-16-1	1
49x6	2	62x3	5								

RELATED PROD



## SS-85 • STANDARD BRASS FITTINGS ASSORTMENT

Instant service for service stations, car dealers, repair shops. Contains 85 of the fastest moving Weatherhead brass fittings.

Compact, lightweight plastic box stores easily in a drawer, shelf or service truck. Saves you time and money by having the right fitting when it is needed. Eliminates searching and make-shift repairs by giving you the right part when you need it most.

**SIZE:** 11" wide, 1-3/4" high, 6-3/4" deep. **WEIGHT:** 3-1/4 lbs.

Catalog Number	Qty.	Catalog Number	Qty.	Catalog Number	Qty.
60x3	5	62x6	2	202x5	5
60x4	10	68x4	2	402x4	2
60x5	5	105x3	5	3151x2	2
60x6	5	105x4	5	3220x4x2	5
62x3	2	105x5	10	3300x2	5
62x4	5	202x4	5	BF-40X	1
62x5	5				



## SS-86 • COMPRESSION FITTINGS ASSORTMENT

Assortment contains 80 of the fastest moving compression fittings.

**SIZE:** 11" wide, 1-3/4" high, 6-3/4" deep. **WEIGHT:** 3-1/2 lbs.

Catalog Number	Qty.	Catalog Number	Qty.	Catalog Number	Qty.
60x3	5	61x5	5	68x3	2
60x4	10	61x6	5	68x4	5
60x5	5	62x3	5	68x5	2
60x6	5	62x4	5	69x3	2
61x3	5	62x5	5	69x4	5
61x4	5	62x6	2	69x5	2
				BF-40X	1



## SS-87 • INVERTED FLARE ASSORTMENT

Assortment contains 84 of the fastest moving inverted fittings.

**SIZE:** 11" wide, 1-3/4" high, 6-3/4" deep. **WEIGHT:** 3-1/2 lbs.

Catalog Number	Qty.	Catalog Number	Qty.	Catalog Number	Qty.
105x3	5	202x5	5	402x3	5
105x4	5	202x6	2	402x4	5
105x5	5	302x3	5	402x5	5
105x6	5	302x4	5	402x6	5
202x3	5	302x5	5	7896x3	5
202x4	5	302x6	2	7896x4	5
				BF-40X	1



### SS-88 • BRASS PIPE ASSORTMENT

Assortment contains 59 of the fastest moving brass pipe fittings.

**SIZE:** 11" wide, 1-3/4" high, 6-3/4" deep. **WEIGHT:** 3-1/2 lbs.

Catalog Number	Qty.	Catalog Number	Qty.	Catalog Number	Qty.
3152x2	5	3326x2	5	3400x2	5
3152x4	5	3326x4	5	3400x4	2
3152x6	2	3326x6	2	3400x6	2
3220x4x2	2	3350x2	5	3500x2	2
3220x6x4	2	3350x4	4	3500x4	2
3300x2	5	3350x6	2	BF-40X	1
3300x4	2				



### BF-40 • HYDRAULIC BRAKE FITTINGS ASSORTMENT

The BF-40 assortment of fast moving hydraulic brake fittings is a must for any shop doing brake service work. Contains the adapters needed to convert large size ports in master cylinders to accept standard steel brake lines plus the brass tees used in the installation of electric towed trailer brakes.

Assortment is organized in a compact, handy plastic box for easy selection.

**SIZE:** 11" wide, 1-3/4" high, 6-3/4" deep. **WEIGHT:** 4 lbs. (approx.)

Catalog Number	Qty.	Catalog Number	Qty.	Catalog Number	Qty.
7818	2	7901	2	7911	2
7828	2	7904	2	7912	2
7829	2	7905	2	7913	2
7897	2	7906	2	7914	2
7898	2	7908	2	7917	2
7900	2	7910	2	7933	2
				BF-40X	1



### BF-41 • HYDRAULIC BRAKE LINE ADAPTER ASSORTMENT

The BF-41 assortment contains the adapters needed to convert the oversize master cylinder ports to accept the inverted flare nut used on standard replacement steel brake lines. The adapters eliminate the need to cut line, install oversize nut and double flare tubing as well as converting the port to standard size threads for the life of the car. Extra standard nuts and the unions needed to connect two steel brake lines when a non-standard length is required are also included in the assortment. The contents including the illustrations of parts are shown on the inside cover of the box.

**SIZE:** 11" wide, 1-3/4" high, 6-3/4" deep. **WEIGHT:** 4 lbs. (approx.)

Catalog Number	Qty.	Catalog Number	Qty.	Catalog Number	Qty.
105x3	10	302x4	5	7896x3	5
105x4	10	302x5	5	7896x4	5
105x5	10	302x6	2	7897	2
105x6	5	7818	2	7908	2
105x6x7	2	7828	2	7917	2
302x3	5	7829	2	BF-40X	1



## BF-42 • RV BRAKE LINE ADAPTER ASSORTMENT

The BF-42 assortment contains the adapter tees required to install the control switch used to coordinate the electric trailer brakes with the hydraulic brakes on towing vehicle. The assortment also contains inverted brake line nuts and unions needed to make up non-standard steel brake line lengths.

**SIZE:** 11" wide, 1-3/4" high, 6-3/4" deep. **WEIGHT:** 4 lbs.

Catalog Number	Qty.	Catalog Number	Qty.	Catalog Number	Qty.
7898	1	7906	1	105x6	5
7899•	1	7914	1	105x6x7	2
7900	1	7933	1	302x3	5
7901	1	105x3	10	302x4	5
7902	1	105x4	10	302x5	5
7904	1	105x5	10	BF-40X	1
7905	1				



## BF-43 • METRIC BRAKE ADAPTER AND TEE ASSORTMENT

The BF-43 assortment contains metric thread connectors to adapt the three port sizes in late model GM cars to use a steel brake line with metric threads (M10x1.0) and standard flare (Weatherhead J series). Included as well are metric adapters to convert European Bubble flare type ports to accept standard 3/16" U.S. steel brake lines, and metric towed trailer brake tees used in controls of electric trailer brakes. The 3/16" unions are used for joining metric and U.S. steel brake lines to make up non-standard lengths.

**SIZE:** 11" wide, 1-3/4" high, 6-3/4" deep.

Catalog Number	Qty.	Catalog Number	Qty.	Catalog Number	Qty.
7918•	1	7936	1	105x4	5
7919•	1	7937	1	1442	5
7920•	1	7940	5	1443	5
7921	1	7941	5	302x3	5
7922•	1	7896x3	5	BF-40X	1
7934A	5	7896x4	5		
7935	1	105x3	10		





### DC-121 • PLASTIC DRAIN COCK ASSORTMENT

To address your plastic drain cock needs, Weatherhead now offers a full assortment of domestic and offshore drain cocks. This kit comes complete with a plastic box and a label with part number and application information.

Catalog Number	Qty.	Catalog Number	Qty.	Catalog Number	Qty.
110	2	113	2	116	2
111	2	114	2	117	2
112	2	115	2	135	2
				145	2

### PC-48 • PUSH > CONNECT FITTINGS ASSORTMENT

Weatherhead PUSH > CONNECT fittings are designed for quick assembly without the need for a wrench. Ideal for pneumatic applications where space is tight. Then fittings are also easily disconnected; simply depress the collet ring with two fingers and withdraw the tube. The PC-48 provides the 48 most popular PUSH > CONNECT fittings in a compact, handy plastic box to make your assortment organized and accessible.



Catalog Number	Qty.	Catalog Number	Qty.	Catalog Number	Qty.
1162x2	5	1168x2.5A	5	1169x4S	5
1162x4	5	1168x2.5x4	5	1169x4x4S	5
1162x6	5	1168x2x4	5	1169x4x6S	5
1164x2.5	5	1168x4	5	1169x6S	5
1164x4	5	1168x4A	5	1169x6x6S	5
1164x6	5	1168x4x4	5	1169x8S	2
1164x8	2	1168x4x6	5	1169x8x4S	2
1165x2.5	5	1168x5	5	1171x4S	5
1165x4	5	1168x5x4	5	1171x4x4S	5
1165x6	5	1168x6	5	1171x6S	5
1165x8	2	1168x6x6	5	1172x4S	5
1166x4	5	1168x6x8	2	1172x4x4S	5
1166x4x4	5	1168x8	5	1174x2	5
1166x6	5	1168x8x8	2	1174x4	5
1166x6x6	2	1169x2.5S	5	CL-499	1
1168x2	2	1169x2S	5	FC-16X	1
1168x2.5	5	1169x2x4S	5		

RELATED PROD



## BA-84 • STEEL BRAKE LINE ASSORTMENT

The BA-84 attractive lobby merchandiser displays domestic as well as import car (British, European and Japanese) steel brake lines. The BA-84 puts brake lines where users can make fast and easy selection from a complete inventory protected by sturdy cardboard color-coded tubes.

The corrosion and vibration resistant double wall steel brake lines are easily formed into the configurations you need without kinking. Longer or non-standard lengths can be made up by joining two lines with a Weatherhead union of the proper thread size.

The BA-84 includes all sizes of the 3/16", 1/4" and 5/16" Weatherhead steel brake lines for domestic cars and trucks plus a sturdy steel rack. Order the SB series (Jaguar, M.G., Triumph), SC series (BMW, Mercedes, Peugeot, Porsche, Volkswagen), SJ series (Mazda, Nissan, Toyota) and Weatherhead import car steel brake lines and unions from listings in brake line section of this catalog. See page 130.

Increase your sales — Organize your inventory — Make selections easy — Discover the results of putting this proven money maker to work for you — Install a BA-84 **NOW**.

3/16" LINES			1/4" LINES		
Length	Catalog Number	Quantity	Length	Catalog Number	Quantity
6"	S306	4	12"	S412	4
8"	S308	4	20"	S420	4
12"	S312	4	30"	S430	4
20"	S320	4	40"	S440	4
30"	S330	4	51"	S451	4
40"	S340	4	60"	S460	4
51"	S351	4			
60"	S360	4			
72"	S372	4			

5/16" LINES					
Length	Catalog Number	Quantity	Length	Catalog Number	Quantity
12"	S512	4		BA-84X	1
20"	S520	4			
30"	S530	4			
40"	S540	4			
51"	S551	4			
60"	S560	4			

WEATHERHEAD  
STEEL BRAKE LINES



WEATHERHEAD  
STEEL BRAKE LINES  
FOR IMPORTED CARS

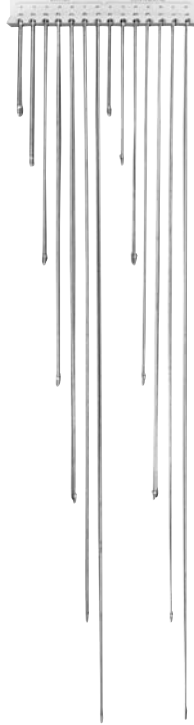

### BA-24 • STEEL BRAKE LINE ASSORTMENT

The BA-24 assortment includes an assortment of 5/16" steel brake lines and a rack for wall or bin installation. The multi-walled corrosion resistant tubing can be easily formed for time saving installation. All lines have color-coded label attached for easy identification. Non-standard lengths can be made up by joining two standard lengths with a 302x5 union. **WEIGHT:** 6 lbs.

Length	Catalog Number	Quantity	Length	Catalog Number	Quantity	Length	Catalog Number	Quantity
12"	S512	4	30"	S530	4	51"	S551	4
20"	S520	4	40"	S540	4	60"	S560	4
							BA-24X	1

### BA-28 • STEEL BRAKE LINE ASSORTMENT

BA-28 contains 3/16" easy to form, anti-corrosive, multi-walled steel brake lines for Japanese vehicles. The SJ lines with 10-1.0mm threads (standard flare) can be joined to form longer lines by using the 7934A Japanese metric union. The handy wall rack is included.

Length	Catalog Number	Quantity	Length	Catalog Number	Quantity	Length	Catalog Number	Quantity
8"	SJ308	4	30"	SJ330	4	51"	SJ351	4
12"	SJ312	4	40"	SJ340	4	60"	SJ360	4
20"	SJ320	4					BA-28X	1

### BA-38 • STEEL BRAKE LINE ASSORTMENT

BA-38 contains six different lengths made of 3/8" multi-walled, easily formed, anti-corrosive steel tubing with inverted flare nuts attached. All lines have color-coded label for easy identification. Non-standard length lines may be fabricated by joining two 3/8" steel lines with a 302x6 union. **WEIGHT:** 8 lbs.

Length	Catalog Number	Quantity	Length	Catalog Number	Quantity	Length	Catalog Number	Quantity
12"	S612	4	30"	S630	4	51"	S651	4
20"	S620	4	40"	S640	4	60"	S660	4
							BA-38X	1

### BA-48 • STEEL BRAKE LINE ASSORTMENT

BA-48 contains the most popular steel brake lines and an easy to install rack. The 3/16" and 1/4" steel brake lines are available in six different lengths. Each steel brake line has a standard inverted flare nut on one end and a long thread inverted flare nut on the other end for better sealing. Easy to form, multi-walled steel tubing resists corrosion and vibration.

Non-standard length lines may be fabricated by joining two 3/16" lines with a 302x3 and two 1/4" lines with a 302x4. **WEIGHT:** 10-1/2 lbs.

3/16" LINES			1/4" LINES			1/4" LINES		
Length	Catalog Number	Quantity	Length	Catalog Number	Quantity	Length	Catalog Number	Quantity
12"	S312	4	12"	S412	4	51"	S451	4
20"	S320	4	20"	S420	4	60"	S460	4
30"	S330	4	30"	S430	4		BA-48X	1
40"	S340	4	40"	S440	4			
51"	S351	4						
60"	S360	4						

### BA-56 • STEEL BRAKE LINE ASSORTMENT

BA-56 contains 3/16" easy to form, anti-corrosive, multi-walled steel brake lines for British and European cars. The SB lines with 3/8-24 threads (Bubble Flare) can be joined to form longer lines by using the 7940 metric union. SC lines with 10X1.0mm threads (Bubble Flare) can be joined with the 7941 metric union. The handy wall rack is included. **WEIGHT:** 10 lbs.

British 3/8-24 Thread			European 10-1.0mm Thread			European 10-1.0mm Thread		
Length	Catalog Number	Quantity	Length	Catalog Number	Quantity	Length	Catalog Number	Quantity
8"	SB308	4	8"	SC308	4	40"	SC340	4
12"	SB312	4	12"	SC312	4	51"	SC351	4
20"	SB320	4	20"	SC320	4	60"	SC360	4
30"	SB330	4	30"	SC330	4		BA-56X	1
40"	SB340	4						
51"	SB351	4						
60"	SB360	4						

RELATED PROD

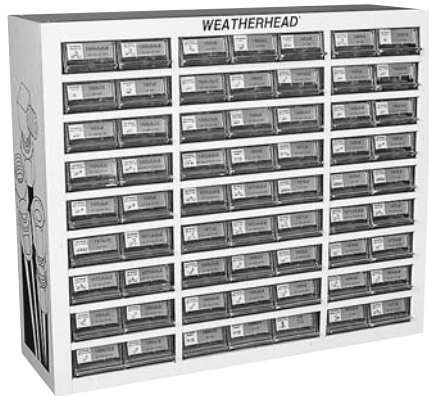

## AB-1400 • AIR BRAKE FITTINGS ASSORTMENT

The AB-1400 contains DOT approved brass air brake fittings for servicing nylon brake and secondary air lines. Selecting the proper fittings from the 63 drawer cabinet included with assortment is easy. Clear, wide plastic drawers with color-coded labels make identification of shapes and sizes quick and simple. Order Weatherhead NT100 nylon air brake tubing to complete your nylon air brake line service center.

### AB-1400 Contents

Catalog Number	Quantity	Catalog Number	Quantity	Catalog Number	Quantity	Catalog Number	Quantity
1460x4	10	1464x6	5	1469x6	10	1471x8	4
1460x6	20	1464x8	5	1469x6L	5	1472x6	5
1460x8	10	1466x6	5	1469x6x2	5	1472x8	5
1460x10	10	1466x6x2	5	1469x6x6	5	1480x6	5
1460x12	10	1466x6x6	5	1469x8	5	1480x6x6	5
1461x4	5	1466x8	5	1469x8x4	5	1480x8	5
1461x6	10	1468x4	5	1469x10	5	1480x10	4
1461x8	5	1468x4x4	5	1469x10x6	4	1484x4	20
1461x10	5	1468x6	10	1469x12	4	1484x6	20
1461x12	5	1468x6x2	5	1470x6	5	1484x8	20
1462x4	5	1468x8	5	1470x6x6	5	1484x10	10
1462x6	10	1468x10	5	1470x8	4	1484x12	10
1462x8	5	1468x12	4	1471x4	5	C-63X	1
1462x10	4	1469x4	5	1471x6	5	CL-497	1
1462x12	2	1469x4x4	5				



## AB-140 • 1400 SERIES AIR BRAKE FITTINGS ASSORTMENT

This assortment of 1/4", 3/8", 1/2" air brake fittings designed for use with NT100 nylon air brake tubing provides the coverage needed for service work by fleets, repair shops and farm implement dealers. The DOT approved air brake fittings are easily selected from the cabinet with 16 plastic drawers and color-coded labels included in the assortment.

### AB-140 Contents

Catalog Number	Quantity	Catalog Number	Quantity	Catalog Number	Quantity	Catalog Number	Quantity
1460x4	20	1461x8	5	1468x6	10	1484x6	20
1460x6	20	1462x4	5	1468x8	5	1484x8	20
1460x8	20	1462x6	10	1469x4	5	145	10
1461x4	10	1462x8	4	1469x6	5	W15310	5
1461x6	10	1468x4	10	1469x8	5	FC-16X	1
				1484x4	20	CL-16-3	1

### QC-18

Designed as a glove box sized emergency repair kit, the QC-18 assortment contains Q-CAB® tube unions in 5/32", 1/4", 3/8" and 1/2" sizes, also included is a T-191 tubing cutter. The contents are contained in a convenient carrying case measuring 1-1/4"x3-3/4"x7".



Component Part Number	Quantity
QC-18X	1
T-191	1
1862x2.5	2
1862x4	2
1862x6	2
1862x8	2

### QC-180

The QC180 contains tube unions, male connectors, swivel male 45° elbow, male 90° elbows and repair kits in popular 1/4", 3/8" and 1/2" tube sizes designed for D.O.T. Truck and Trailer Air Brake System needs (see complete listing below). The Q-CAB® fittings are field proven with over 15,000,000 miles of leak free performance. Their design can save up to 75% of the assembly time over conventional compression fittings. These fittings are contained in a case measuring 1-3/4"x6-3/4"x1-3/4".



QC-180	Contents Part Number	Quantity	Contents Part Number	Quantity
	1862x4	2	1869x6x6	2
1862x6	2	1869x8x8	1	
1862x8	2	1880x4x4	2	
1868x2.5	2	1880x6x6	2	
1868x3	2	1880x8x8	1	
1868x4x4	2	1800Kx4	2	
1868x6x6	2	1800Kx6	2	
1868x8x8	2	1800Kx8	2	
1869x4x4	2	1800TRK	1	
		BF40X	1	

### QC-1800

This assortment contains a solid inventory of popular Weatherhead Q-CAB® fittings designed for D.O.T. Truck and Trailer Air Brake System needs (see complete listing below). The Q-CAB® fittings are field proven with over 15,000,000 miles of leak free performance. Their design can save up to 75% of the assembly time over conventional compression fittings.



QC-1800	Contents Part Number	Quantity	Contents Part Number	Quantity	Contents Part Number	Quantity	Contents Part Number	Quantity
	1800Kx2.5	4	1868x2.5x1	5	1869x4	5	1874x8x8	1
1800Kx3	4	1868x2.5	5	1869x4x4	5	1880x4x4	5	
1800Kx4	4	1868x3	5	1869x6	5	1880x6x6	5	
1800Kx6	4	1868x4	5	1869x8	5	1880x8x8	5	
1800Kx8	4	1868x4x4	5	1869x8x8	5	1880x10	2	
1800Kx10	2	1868x6	5	1869x10	2	1880x12	2	
1800Kx12	2	1868x6x6	5	1869x4S	5	1800T	1	
1862x2.5	2	1868x8	5	1869x4x4S	5	T191	1	
1862x4	5	1868x8x8	5	1869x6S	5	FC16X	1	
1862x6	5	1868x10x6	2	1869x8S	5	CL503	1	
1862x8	5	1868x10	2	1874x4x4	1			
1862x10	2	1868x12	2	1874x6x6	1			

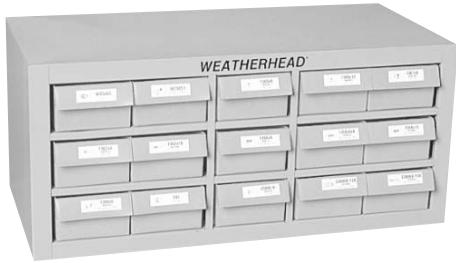

## AB-45 • AIR BRAKE FITTINGS ASSORTMENT

This assortment of draincocks, shutoffs and air brake fittings for use with 1/4", 3/8", 1/2" copper tubing is a must for jobbers and fleet service shops. Provides excellent coverage for air brake tube and hose service requirements. The large plastic drawers and the illustrated labels for the 15 drawer cabinet included in assortment make positive part selection simple and quick.

### AB-45 Contents

Catalog Number	Quantity	Catalog Number	Quantity	Catalog Number	Quantity	Catalog Number	Quantity
1360x6	20	1368x6	10	145	10	6747	1
1360x8	20	1368x6x2	5	33806-A	20	6748	1
1360x10	10	1368x6x6	5	33806-B	5	6749	1
1360x12	10	1368x8	5	33806B-Y06	2	FH-15X	1
1361x6	20	1368x10	5	33806B-Y24	5	FS-800	1
1361x8	5	1369x4x4	5	33806B-Y28	5	W05465	5
1361x10	5	1369x6	10	33806B-Y34	5	W14630	10
1362x4	5	1369x8	5	33806B-Y38	5	W15310	5
1362x6	10	1380x6	5	6707	1	W76150	5
1362x8	5	1390x6	5	6708	1	W79850	3
1362x10	5	1391x6	5	6709	1	W79851	3



## AB-28 • AIR BRAKE FITTINGS ASSORTMENT

The 1/4", 3/8", 1/2" brass air brake fittings for use with copper tubing provide excellent coverage for fleets, independent repair shops and farm implement dealers doing service work.

With the AB-28 assortment you also receive a cabinet with clear plastic drawers plus illustrated, color-coded labels that assure fast, positive identification and selection of replacement fittings.

### AB-28 Contents

Catalog Number	Quantity	Catalog Number	Quantity	Catalog Number	Quantity	Catalog Number	Quantity
1360x4	20	1361x10	5	1368x8	5	33806B-Y28	5
1360x6	20	1361x12	5	1369x4	5	33806B-Y34	5
1360x8	20	1362x6	5	1369x6	10	33806B-Y38	5
1360x10	10	1362x8	5	145	10	CL-16-2	1
1360x12	10	1362x10	5	33806-A	20	FC-16X	1
1361x4	5	1368x4	5	33806B-Y06	2	W14630	10
1361x6	20	1368x6	10	33806B-Y24	5	W15310	5
1361x8	5	1368x6x6	5				



### SA-1 • SECONDARY AIR SYSTEMS KIT

Ideal for fleet repair shops, truck dealers, garages and truck stops. SA-1 contains an assortment of popular 1/8" and 1/4" brass fittings plus 200' of Weatherhead NT100 SAE J844 Nylon tubing. The 1/8" fittings are Weatherhead SELFALIGN® and 1/4" fittings are Weatherhead 1400 series air brake. The sturdy box keeps the tubing and fittings together for quick and easy servicing of the tubing used on shifters, PTO's, wipers, horns, remote air, instrumentation, etc. All of the parts are organized at your finger tips. The SA-1 is a must for all vehicle air system maintenance facilities.

**Size:** 15" wide, 3-1/2" high, 14-1/2" deep.

Catalog Number	Qty.	Catalog Number	Qty.
NT10002BK-100	100'	1460x4	10
NT10004BK-100	100'	1461x4	5
601x2	10	1462x4	2
611x2	5	1464x4	1
621x2	2	1468x4	2
661x2	2	1468x4x1	2
681x2	2	1468x4x4	2
681x2x1	2	1469x4	2
691x2	2	1469x4x4	2
691x2x1	2	1484x4	5
FS-SA-1	1	BF-40X	1



### SA-2 • SECONDARY AIR SYSTEMS KIT

The SA-2 assortment enables you to supply fleets and dealers with fittings and tubing for 1/4" and 3/8" O.D. air brake applications. 1/8" O.D. tubing and fittings are also supplied for applications such as transmission shifter, air horn, gauge and flat adjustment. A cabinet is also supplied for easy storage on shelves and bench tops.

Catalog Number	Qty.	Catalog Number	Qty.
601x2	10	1472x4	5
611x2	10	1472x6	5
621x2	5	1472x6x6x6	5
661x2	5	1484x4	10
681x2	5	1484x6	10
681x2x1	2	1485x4	10
691x2	5	1485x6	10
691x2x1	2	1468x6	10
1460x4	10	1468x6x2	5
1460x6	20	1468x6x6	5
1461x4	5	1468x6x8	5
1461x6	10	1469x4	5
1462x4	5	1469x4x4	5
1462x6	10	1469x6	10
1464x4	2	1469x6x6	5
1464x6	2	NT10002BK-100	100'
1466x6	5	NT10004BK-100	100'
1468x4	5	NT10006BK-100	100'
1468x4x4	5	BL-456-X	1
1468x4x6	2	FS-SA-2	1

RELATED PRODUCTS



## AB-8 & AB-9 • Air Brake Air Chamber Hose

### Assembly Assortment of 3/8" and 1/2" I.D. Lines

Each selection of ready-made air chamber hose assemblies facilitates replacement of hoses. Eliminates time and cost of making special assemblies. Wall rack keeps assemblies handy and ready to use.

### AB-8 • 1/2" I.D. Air Brake Air Chamber Lines

Length	Qty.	Catalog Number	Length	Qty.	Catalog Number
18-1/2"	1	38353-01800	32"	1	38353-03200
20-3/8"	1	38353-02037	34-3/8"	1	38353-03437
24-1/8"	1	38353-02400	36-1/8"	1	38353-03600
28-3/8"	1	38353-02837	41-1/8"	1	38353-04112
30-1/8"	1	38353-03000		1	AB-8X (rack only)

Replacement Labels **AB-8L**

### AB-9 • 3/8" I.D. Lines Air Brake Air Chamber Lines

Length	Qty.	Catalog Number	Length	Qty.	Catalog Number
18-1/2"	1	38166-01812	32"	1	38166-03200
20-3/8"	2	38166-02137	34-3/8"	1	38166-03437
24-1/8"	2	38166-02412	36-1/8"	2	38166-03612
28-3/8"	2	38166-02837	41-1/8"	1	38166-04112
30-1/8"	2	38166-03012		1	AB-9X (rack only)

Replacement Labels **AB-9L**



## CA-130 & CA-230 • Clamp Assortments

You can now increase your all-stainless steel or part-stainless steel clamp sales with these all-purpose clamp assortments. These rugged assortments can be wall mounted or stand free using less than 2 sq. ft. of counter space. They load easily and organize your merchandise effectively.

### CA-130 • Part-Stainless Steel

Catalog Number	Quantity	Catalog Number	Quantity
6205-004	20	6203-024	10
6205-006	10	6203-036	10
6203-010	20	CA-10X (rack only)	1
6203-016	20		
6203-020	20		

### CA-230 • All-Stainless Steel

Catalog Number	Quantity	Catalog Number	Quantity
6204-010	20	6206-004	20
6204-016	20	6206-006	10
6204-020	20	CA-10X (rack only)	1
6204-024	10		
6204-036	10		



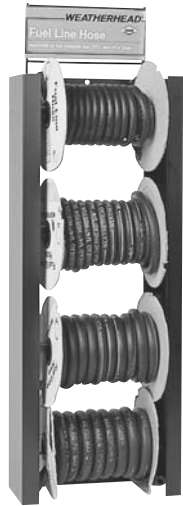

### HA-574 • Fuel Hose Merchandiser

Now you can make those custom hose assemblies in minutes for instant service on fuel and oil line replacements. The attractive HA-574 includes H057 hose in all popular sizes for low pressure fuel, EEC and PCV lines. Weatherhead H057 low pressure fuel line hose has Nitrile inner tube, fiber braid reinforcement, and Hypalon cover for long life compatibility with gasohol, leaded and unleaded fuels. The HC-574X rack can be easily installed on pegboard, wall, or metal shelving with the included hardware.

Catalog Number	Quantity	Description
H05703	25'	Hose
H05704	25'	Hose
H05705	25'	Hose
H05706	25'	Hose
HC-574X	1	Rack



### BL-456 • Barb-Tite® Fittings and Hose Assortment

Making up an air line – oil line – transmission or power steering return line? The BL-456 assortment puts Weatherhead Barb-Tite® fittings and 1/4", 5/16", and 3/8" I.D. 350 PSI maximum operating pressure H101 hose at your fingertips for quick and easy assembly. Simply push ends on hose, and you have a hose assembly. No clamps required!

Your hose will be kept clean and easily accessible on three shelves in the cabinet. Measure the hose on top of the cabinet with the rule provided and then select the proper hose ends from the assortment in the two metal drawers. Within minutes the hose assembly is ready for installation.

**Size:** 15" wide, 16-1/2" high, 13-3/16" deep

16 Compartments in each drawer.

Catalog Number	Qty.	Catalog Number	Qty.
10004B-102	4	10004B-B04	4
10004B-104	4	10004B-B05	4
10004B-304	4	10004B-Y04	4
10004B-305	4	10005B-102	4
10004B-405	4	10005B-104	4
10004B-604	4	10005B-405	4
10004B-A04	4	10005B-B05	4
10004B-A05	4	10005B-B06	4
10004B-B03	4		
Catalog Number	Qty.	Catalog Number	Qty.
10005B-C02	4	10006B-606	4
10005B-C04	4	10006B-B06	4
10005B-Y05	4	10006B-Y06	4
10006B-102	4	H10104	25'
10006B-104	4	H10105	25'
10006B-106	4	H10106	25'
10006B-306	4	FS-501	1
10006B-406	4	BL-456X	1

RELATED PRODUCTS

These assortments are ideal for servicing that fleet account. The D.O.T. approved hose and fittings will enable the user to make up chamber lines, connect to gladhand couplings, and provide routing for air brake lines. The general purpose H069 provides for fuel, oil, water, power steering, and transmission lines. A self-contained assortment in a super cabinet, all set up for easy serviceability!



## FA-100 • Fleet Hose and Fitting Assortment

Catalog Number	Qty	Catalog Number	Qty	Catalog Number	Qty
H06904	50'	24706N-106	5	24710N-608	5
H06906	50'	24706N-406	5	24710N-610	2
H06908	50'	24706N-604	5	33806-A	20
H06910	50'	24706N-605	5	33806-B	5
H16606	50'	24706N-606	5	33806B-Y06	5
H16608	50'	24706N-608	5	33806B-Y24	5
H33806	50'	24706N-756	5	33806B-Y26	2
24704N-102	5	24706N-B06	5	33806B-Y28	5
24704N-104	5	24708N-106	5	33806B-Y34	5
24704N-604	5	24708N-108	5	33806B-Y36	5
24704N-B04	5	24708N-406	5	33806B-Y38	5
24705N-104	5	24708N-608	5	FH-15X	1
24705N-605	5	24710B-Y58	2	HD-1X	1
24705N-B05	5	24710B-Y60	5		
24706N-104	5	24710N-108	5		

## FA-100-CO • Fleet Hose and Fitting Assortment (Contents Only)

Catalog Number	Qty	Catalog Number	Qty	Catalog Number	Qty
H06904	50'	24706N-106	5	24710N-608	5
H06906	50'	24706N-406	5	24710N-610	2
H06908	50'	24706N-604	5	33806-A	20
H06910	50'	24706N-605	5	33806-B	5
H16606	50'	24706N-606	5	33806B-Y06	5
H16608	50'	24706N-608	5	33806B-Y24	5
H33806	50'	24706N-756	5	33806B-Y26	2
24704N-102	5	24706N-B06	5	33806B-Y28	5
24704N-104	5	24708N-106	5	33806B-Y34	5
24704N-604	5	24708N-108	5	33806B-Y36	5
24704N-B04	5	24708N-406	5	33806B-Y38	5
24705N-104	5	24708N-608	5		
24705N-605	5	24710B-Y58	2		
24705N-B05	5	24710B-Y60	5		
24706N-104	5	24710N-108	5		

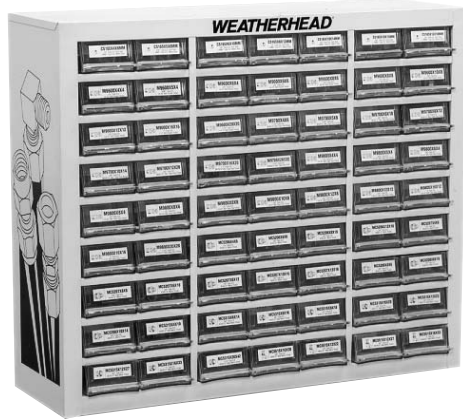

### MA-100 • Metric Adapter Assortment

The MA-100 is an ideal assortment to begin a metric adapter inventory. Offered are a variety of male British Standard Tapered Pipe and British Standard Parallel fittings in straight and 90° elbow configurations, sizes ranging from 1/8" through 1-1/4". Two male DIN (German metric) fittings adapt SAE fittings and hose ends to metric size tubing, and a third DIN fitting connects SAE fittings with metric female swivel adapters, sizes ranging from 6mm through 42mm. The C5165X metric sleeves adapt metric tubing used with standard JIC fittings. The MA-100 is supplied with cabinet for accurate and easy access to your metric fittings.

Replacement Drawers: [PD-49](#)  
 Replacement Dividers: [PD-75 Set](#) (25/set)

### MA-100 Contents

Catalog Number	Qty.	Catalog Number	Qty.	Catalog Number	Qty.	Catalog Number	Qty.	Catalog Number	Qty.
7165X6MM	5	M9700X5X8	2	MB5515X6X4	5	MC5208X6X6	2	MH7105X6	5
7165X8MM	2	M9700X6X10	2	MB5515X6X6	5	MC5208X8X10	2	MH7105X8	5
7165X10MM	5	M9700X8X12	2	MB5515X8X6	5	MC5208X10X14	2	MH7105X10	5
7165X12MM	5	M9700X10X14	2	MB5515X8X8	5	MC5208X12X16	2	MH7105X12	5
7165X14MM	5	M9700X12X20	2	MB5515X10X12	5	MC5315X4X10	2	MH7105X14	5
7165X15MM	5	M9700X16X25	2	MB5515X12X12	5	MC5315X4X12	2	MH7105X16	5
7165X16MM	5	M9700X20X32	1	MB5515X16X16	2	MC5315X6X14	2	MH7105X20	5
7165X18MM	5	M9800X4X4	2	MB5515X20X20	2	MC5315X6X16	2	MH7105X25	5
7165X20MM	5	M9800X5X4	2	MC5205X4X2	5	MC5315X8X18	2	MH7105X30	5
7165X22MM	5	M9800X6X4	2	MC5205X4X4	5	MC5315X10X20	2	ML7105X6	5
7165X25MM	5	M9800X8X4	2	MC5205X5X4	5	MC5315X12X22	2	ML7105X8	5
7165X28MM	5	M9800X8X6	2	MC5205X6X4	5	MC5315X12X27	2	ML7105X10	5
7165X30MM	5	M9800X8X8	2	MC5205X6X6	5	MC5315X16X33	2	ML7105X12	5
M7629X10	5	M9800X10X8	2	MC5205X8X6	5	MC5315X20X42	1	ML7105X15	5
M7629X14	5	M9800X12X8	2	MC5205X8X8	5	MC5405X4X4	5	ML7105X18	5
M7629X16	5	M9800X12X12	2	MC5205X10X8	5	MC5405X5X4	5	ML7105X22	5
M7629X18	5	M9800X16X12	2	MC5205X10X12	5	MC5405X6X4	5	ML7105X28	5
M7629X20	5	M9800X16X16	2	MC5205X12X12	5	MC5405X6X6	5	C5165X4X6MM	5
M7629X22	5	M9800X20X20	1	MC5205X16X16	2	MC5405X8X6	5	C5165X5X8MM	5
M7629X27	5	MB5315X4X2	5	MC5205X20X20	2	MC5405X8X8	5	C5165X6X10MM	5
M7629X33	5	MB5315X4X4	5	MC5206X4X6	2	MC5405X10X12	5	C5165X8X12MM	5
M7629X42	5	MB5315X5X4	5	MC5206X6X8	2	MC5405X12X12	5	C5165X10X14MM	5
M9600X4X4	2	MB5315X6X4	5	MC5206X8X10	2	MC5405X16X16	2	C5165X10X15MM	5
M9600X5X4	2	MB5315X6X6	5	MC5206X8X12	2	MC5405X20X20	2	C5165X10X16MM	5
M9600X6X4	2	MB5315X8X6	5	MC5206X10X15	2	MC5515X4X12	2	C5165X12X18MM	5
M9600X6X6	2	MB5315X8X8	5	MC5206X12X18	2	MC5515X6X14	2	C5165X14X20MM	5
M9600X8X6	2	MB5315X10X12	5	MC5207X4X6	2	MC5515X6X16	2	C5165X16X25MM	5
M9600X8X8	2	MB5315X12X12	5	MC5207X6X8	2	MC5515X8X18	2	C5165X20X30MM	5
M9600X10X8	2	MB5315X16X16	2	MC5207X6X10	2	MC5515X10X20	2	C5165X20X32MM	5
M9600X12X12	2	MB5315X20X20	2	MC5207X8X12	2	MC5515X12X22	2	C-5X	1
M9600X16X16	2	MB5515X4X4	5	MC5207X10X15	2	MC5515X12X27	2	C-63X	1
M9600X20X20	1	MB5515X5X4	5	MC5207X12X18	2	MC5515X16X33	1	CL-502	1
M9700X4X6	2							TA-1002	1

RELATED PRODUCT



## MA-200 • Metric Hose End Assortment

The MA-200 Hose End Assortment offers an excellent introductory stock of metric hose ends. Coverage includes 'U' Series British Standard Tapered Pipe (BSPT) and British Standard Parallel Pipe (BSPP) in male straight, and female swivel in straight and 90° tube elbow connections, swivels, and split flange ends for Komatsu and Link Belt applications and DIN standpipe hose ends in light and heavy series. One FH-15X stock cabinet is supplied for storage.

### MA-200 Contents

Catalog Number	Qty.	Catalog Number	Qty.	Catalog Number	Qty.	Catalog Number	Qty.	Catalog Number	Qty.
04U-14K	2	06U-76P	2	12U-162	2	16U-P66	2	MH7105X14	2
04U-154	5	08U-158	5	12U-30K	2	7165X8MM	5	MH7105X16	2
04U-354	5	08U-22K	2	12U-362	2	7165X10MM	4	MH7105X20	2
04U-38T	2	08U-358	5	12U-52T	2	7165X12MM	2	MH7105X25	2
04U-40T	2	08U-360	5	12U-55T	2	7165X14MM	2	MH7105X30	1
04U-P54	5	08U-45T	2	12U-G12	2	7165X15MM	2	ML7105X8	2
04U-74P	2	08U-46T	2	12U-G42	2	7165X16MM	2	ML7105X10	2
06U-156	5	08U-P56	2	12U-P62	2	7165X18MM	2	ML7105X12	2
06U-18K	2	08U-P58	2	12U-82P	2	7165X20MM	2	ML7105X15	2
06U-356	5	08U-78P	2	16U-166	2	7165X22MM	2	ML7105X18	2
06U-358	2	08U-80P	5	16U-33K	2	7165X25MM	2	ML7105X22	2
06U-40T	2	10U-24K	2	16U-366	2	7165X28MM	2	ML7105X28	2
06U-42T	2	10U-48T	2	16U-58T	2	7165X30MM	1	FH-15X	2
06U-44T	2	10U-50T	2	16U-60T	1	MH7105X8	2	FS-2500	1
06U-P56	2	10U-G09	2	16U-G16	2	MH7105X10	2		
06U-P58	2	10U-G69	2	16U-G46	2	MH7105X12	2		

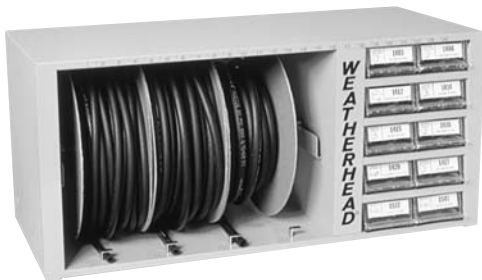

## FL-310 • Fuel Hose and Fittings Assortment

FL-310 contains 250' of Weatherhead fuel line hose, a variety of brass hose end fittings, and gear-type clamps for easy, instant service on fuel and oil line assemblies.

A well-designed cabinet keeps 1/4", 5/16", 3/8", or 7/16" I.D. hose on reels free of kinks and tangles...ready for instant use. Ten clear plastic drawers with color-coded illustrated labels are provided for storing hose end fittings and clamps. H057 hose is compatible with unleaded gasolines and low pressure fuel systems.

**Size:** 30" wide, 13-1/2" high, 13" deep

Catalog No.	Qty.	Catalog No.	Qty.	Catalog No.	Qty.
05704B-102	10	05705B-C04	5	05706B-C04	5
05704B-104	5	05706B-102	10	6202	20
05704B-C02	5	05706B-104	10	CL-434	1
05705B-102	10	05706B-106	5	FL-310X	1
05705B-104	10	05706B-1568	5	H05704	100'
05705B-1560	5	05706B-1570	5	H05705	100'
05705B-1561	5	05706B-C02	5	H05706	50'
05705B-C02	5				

### Dana Corporation Boston Weatherhead Division

Facility	Registration	Registrar Number	Product Responsibility
Antwerp, OH	ISO/QS9000	TUV 74 300 7687	Steel Hose Ends
Brentwood, TN (Engineering)	ISO/QS9000	UL A5225	New Product Designs
Cleveland, TN	ISO9002	SGS US98/1495	Distribution of Weatherhead Product
Columbia City, IN	ISO9002 ISO14001	INTERTEK 97-956	Crimping Equipment
Hohenwald, TN	ISO/QS9000	UL A5216	Industrial and Hydraulic Hose
Ludlow, MA	ISO/QS9000	TUV 74 300 8803	Teflon Hose and Assembly
Newbern, TN	ISO9001	UL A5754	Industrial and Hydraulic Hose
Vinita, OK	ISO/QS9000 ISO14001	UL A5225 A6947	Brass Fittings, Brass Hose Ends, and Valves

# Conversion Chart

Inches			Inches			Inches			Inches		
Fractions	Decimals	MM	Fractions	Decimals	MM	Fractions	Decimals	MM	Fractions	Decimals	MM
-	.0004	.0100	-	.6693	17.0000	1-25/32	1.7810	45.2440	-	3.1102	79.0000
-	.0040	.1000	43/64	.6720	17.0660	-	1.8110	46.0000	3-1/8	3.1250	79.3750
-	.0100	.2500	11/16	.6875	17.4630	1-13/16	1.8125	46.0380	-	3.1496	80.0000
1/64	.0156	.3970	45/64	.7030	17.8590	1-27/32	1.8440	46.8310	3-5/32	3.1560	80.1690
-	.0197	.5000	-	.7087	18.0000	-	1.8504	47.0000	3-3/16	3.1875	80.9630
-	.0295	.7500	23/32	.7190	18.2560	1-7/8	1.8750	47.6250	-	3.1890	81.0000
1/32	.0313	.7940	-	.7283	18.5000	-	1.8898	48.0000	3-7/32	3.2190	81.7560
-	.0394	1.0000	47/64	.7340	18.6530	1-29/32	1.9062	48.4190	-	3.2283	82.0000
3/64	.0469	1.1910	-	.7480	19.0000	-	1.9291	49.0000	3-1/4	3.2500	82.5500
-	.0590	1.5000	3/4	.7500	19.0500	1-15/16	1.9375	49.2130	-	3.2677	83.0000
1/16	.0620	1.5880	49/64	.7656	19.4470	-	1.9685	50.0000	3-9/32	3.2810	83.3440
5/64	.0781	1.9840	25/32	.7810	19.8440	1-31/32	1.9690	50.0060	-	3.3071	84.0000
-	.0787	2.0000	-	.7874	20.0000	2	2.0000	50.8000	3-5/16	3.3120	84.1377
3/32	.0940	2.3810	51/64	.7970	20.2410	-	2.0079	51.0000	3-11/32	3.3440	84.9314
-	.0984	2.5000	13/16	.8125	20.6380	2-1/32	2.0313	51.5940	-	3.3464	85.0000
7.64	.1090	2.7780	-	.8268	21.0000	-	2.0472	52.0000	3-3/8	3.3750	85.7250
-	.1181	3.0000	53/64	.8280	21.0340	2-1/16	2.0620	52.3880	-	3.3858	86.0000
1/8	.1250	3.1750	27/32	.8440	21.4310	-	2.0866	53.0000	3-13/32	3.4060	86.5190
-	.1378	3.5000	55/64	.8590	21.8280	2-3/32	2.0940	53.1810	-	3.4252	87.0000
9/64	.1410	3.5720	-	.8662	22.0000	2-1/8	2.1250	53.9750	3-7/16	3.4380	87.3130
5/32	.1560	3.9690	7/8	.8750	22.2250	-	2.1260	54.0000	-	3.4646	88.0000
-	.1575	4.0000	57/64	.8906	22.6220	2-5/32	2.1560	54.7690	3-15/32	3.4690	88.1060
11/64	.1720	4.3660	-	.9055	23.0000	-	2.1650	55.0000	3-1/2	3.5000	88.9000
-	.1770	4.5000	29/32	.9062	23.0190	2-3/16	2.1875	55.5630	-	3.5039	89.0000
3/16	.1875	4.7630	59/64	.9220	23.4160	-	2.2047	56.0000	3-17/32	3.5310	89.6940
-	.1969	5.0000	15/16	.9375	23.8130	2-7/32	2.2190	56.3560	-	3.5433	90.0000
13/64	.2030	5.1590	-	.9449	24.0000	-	2.2440	57.0000	3-9/16	3.5620	90.4877
-	.2165	5.5000	61/64	.9530	24.2090	2-1/4	2.2500	57.1500	-	3.5827	91.0000
7/32	.2190	5.5560	31/32	.9690	24.6060	2-9/32	2.2810	57.9440	3-19/32	3.5940	91.2810
15/64	.2340	5.9530	-	.9843	25.0000	-	2.2835	58.0000	-	3.6220	92.0000
-	.2362	6.0000	63/64	.9844	25.0030	2-5/16	2.3120	58.7380	3-5/8	3.6250	92.0750
1/4	.2500	6.3500	1	1.0000	25.4000	-	2.3228	59.0000	3-21/32	3.6560	92.8960
-	.2559	6.5000	-	1.0236	26.0000	2-11/32	2.3440	59.5310	-	3.6614	93.0000
17/64	.2656	6.7470	1-1/32	1.0312	26.1940	-	2.3622	60.0000	3-11/16	3.6875	93.6630
-	.2756	7.0000	1-1/16	1.0620	26.9880	2-3/8	2.3750	60.3250	-	3.7008	94.0000
9/32	.2810	7.1440	-	1.0630	27.0000	-	2.4016	61.0000	3-23/32	3.7190	94.4560
-	.2953	7.5000	1-3/32	1.0940	27.7810	2-13/32	2.4060	61.1190	-	3.7401	95.0000
19/64	.2970	7.5410	-	1.1024	28.0000	2-7/16	2.4380	61.9130	3-3/4	3.7500	92.2500
5/16	.3120	7.9380	1-1/8	1.1250	28.5750	-	2.4409	62.0000	-	3.7795	96.0000
-	.3150	8.0000	-	1.1417	29.0000	2-15/32	2.4690	62.7060	3-25/32	3.7810	96.0440
21/64	.3280	8.3340	1-5/32	1.1560	29.3690	-	2.4803	63.0000	3-13/16	3.8125	96.8380
-	.3350	8.5000	-	1.1811	30.0000	2-1/2	2.5000	63.5000	-	3.8189	97.0000
11/32	.3440	8.7310	1-3/16	1.1875	31.1630	-	2.5197	64.0000	3-26/32	3.8440	97.6310
-	.3543	9.0000	1-7/32	1.2190	30.9560	2-17/32	2.5310	64.2940	-	3.8583	98.0000
23/64	.3590	9.1280	-	1.2205	31.0000	-	2.5590	65.0000	3-7/8	3.8750	98.4250
-	.3740	9.5000	1-1/4	1.2500	31.7500	2-9/16	2.5620	65.0880	-	3.8976	99.0000
3/8	.3750	9.5250	-	1.2598	32.0000	2-19/32	2.5940	65.8810	3-29/32	3.9062	99.2190
25/64	.3910	9.9220	1-9/32	1.2810	32.5440	-	2.5984	66.0000	-	3.9370	100.0000
-	.3937	10.0000	-	1.2992	33.0000	2-5/8	2.6250	66.6750	3-15/16	3.9375	100.0130
13/32	.4060	10.3190	1-5/16	1.3120	33.3380	-	2.6380	67.0000	3-31/32	3.9690	100.8060
-	.4130	10.5000	-	1.3386	34.0000	2-21/32	2.6560	67.4690	-	3.9764	101.0000
27/64	.4220	10.7160	1-11/32	1.3440	34.1310	-	2.6772	68.0000	4	4.0000	101.6000
-	.4331	11.0000	1-3/8	1.3750	34.9250	2-11/16	2.6875	68.2630	4-1/16	4.0620	103.1880
7/16	.4380	11.1130	-	1.3779	35.0000	-	2.7165	69.0000	4-1/8	4.1250	104.7750
29/64	.4530	11.5090	1-13/32	1.4060	35.7190	2-23/32	2.7190	69.0560	-	4.1338	105.0000
15/32	.4690	11.9060	-	1.4173	36.0000	2-3/4	2.7500	69.8500	4-3/16	4.1875	106.3630
-	.4724	12.0000	1-7/16	1.4380	36.5130	-	2.7559	70.0000	4-1/4	4.2500	107.9500
31/64	.4840	12.3030	-	1.4567	37.0000	2-25/32	2.7810	70.6439	4-5/16	4.3120	109.5380
-	.4920	12.5000	1-15/32	1.4690	37.3060	-	2.7953	71.0000	-	4.3307	110.0000
1/2	.5000	12.7000	-	1.4961	38.0000	2-13/16	2.8125	71.4376	4-3/8	4.3750	111.1250
-	.5118	13.0000	1-1/2	1.5000	38.1000	-	2.8346	72.0000	4-7/16	4.4380	112.7130
33/64	.5156	13.0970	1-17/32	1.5310	38.8940	2-27/32	2.8440	72.2314	4-1/2	4.5000	114.3000
17/32	.5310	13.4940	-	1.5354	39.0000	-	2.8740	73.0000	-	4.5275	115.0000
35/64	.5470	13.8910	1-9/16	1.5620	39.6880	2-7/8	2.8750	73.0250	4-9/16	4.5620	115.8880
-	.5512	14.0000	-	1.5748	40.0000	2-29/32	2.9062	73.8190	4-5/8	4.6250	117.4750
9/16	.5630	14.2880	1-19/32	1.5940	40.4810	-	2.9134	74.0000	4-11/16	4.6875	119.0630
-	.5710	14.5000	-	1.6142	41.0000	2-15/16	2.9375	74.6130	-	4.7244	120.0000
37/64	.5790	14.6840	1-5/8	1.6250	41.2750	-	2.9527	75.0000	4-3/4	4.7500	120.6500
-	.5906	15.0000	-	1.6535	42.0000	2-31/32	2.9690	75.4060	4-13/16	4.8125	122.2380
19/32	.5940	15.0810	1-31/32	1.6562	42.0690	-	2.9921	76.0000	4-7/8	4.8750	123.8250
39/64	.6090	15.4780	1-11/16	1.6875	42.8630	3	3.0000	76.2000	-	4.9212	125.0000
5/8	.6250	15.8750	-	1.6929	43.0000	3-1/32	3.0312	76.9940	4-15/16	4.9375	125.4130
-	.6299	16.0000	1-23/32	1.7190	43.6560	-	3.0315	77.0000	5	5.0000	127.0000
41/64	.6406	16.2720	-	1.7323	44.0000	3-1/16	3.0620	77.7880			
-	.6496	16.5000	1-3/4	1.7500	44.4500	-	3.0709	78.0000			
21/32	.6560	16.6690	-	1.7717	45.0000	3-3/32	3.0940	78.5810			

### SAE 37° and 45° Flare Fittings For Zinc Plated Carbon without Thread Sealant or Lubrication

Size	Fraction	Decimal	Lb. / In.	Lb. / Ft.	Newton Meters	Additional Turns of Hex-Flats**
- 04	1/4"	0.250	130-150	11-12	15-17	2
- 05	5/16"	0.312	165-195	14-16	19-22	2
- 06	3/8"	0.375	235-265	20-22	27-30	1-1/4
- 08	1/2"	0.500	525-575	44-48	59-65	1
- 10	5/8"	0.625	600-700	50-58	68-79	1
- 12	3/4"	0.750	950-1050	79-88	107-119	1
- 16	1"	1.000	1400-1500	117-125	158-170	1
- 20	1-1/4"	1.250	1900-2100	158-175	215-237	1
- 24	1-1/2"	1.500	2250-2550	188-213	254-288	1
- 32	2"	2.000	3000-3400	250-283	339-384	1

**\*\*Additional Turns of Hex-Flats required after finger tightening. THIS IS THE RECOMMEND METHOD OF TIGHTENING BOTH 37° SWIVELS & 45° FLARE FITTINGS.**

### Straight Thread O-Ring Fittings For Zinc Plated Steel without Sealant or Lubrication

Size	Fraction	Decimal	Lb. / In.	Lb. / Ft.	Newton Meters
- 04	1/4"	0.250	156-180	13-15	18-20
- 05	5/16"	0.312	204-228	17-19	23-26
- 06	3/8"	0.375	264-288	22-24	30-33
- 08	1/2"	0.500	480-516	40-43	54-58
- 10	5/8"	0.625	516-576	43-48	58-65
- 12	3/4"	0.750	816-900	68-75	92-102
- 16	1"	1.000	1344-1476	112-123	152-167
- 20	1-1/4"	1.250	1752-1932	146-161	198-218
- 24	1-1/2"	1.500	1848-2040	154-170	209-231
- 32	2"	2.000	2616-2880	218-240	296-325

### For-Seal® Fittings For Zinc Plated Steel without Thread Sealant or Lubrication

Size	Fraction	Decimal	For-Seal® Swivel Nut Fitting			O-Ring Boss Straight Thread O-Ring Locknut		
			Lb. / In.	Lb. / Ft.	Newton Meters	Lb. / In.	Lb. - Ft.	Newton Meters
- 04	1/4"	0.250	120-144	10-12	14-16	168-192	14-16	19-22
- 06	3/8"	0.375	216-240	18-20	24-27	288-312	24-26	33-35
- 08	1/2"	0.500	384-420	32-35	43-48	600-720	50-60	68-81
- 10	5/8"	0.625	552-600	46-50	62-68	864-960	72-80	98-109
- 12	3/4"	0.750	780-840	65-70	88-95	1500-1620	125-135	170-183
- 16	1"	1.000	1104-1200	92-100	125-136	2400-2640	200-220	271-298
- 20	1-1/4"	1.250	1500-1680	125-140	170-190	2520-3360	210-280	285-380
- 24	1-1/2"	1.500	1800-1980	150-165	203-224	3240-4320	270-360	366-488

### Torque Value Conversion Chart

Lb. / Inch	=	Pound Foot (Lb./Ft.) x 12	Lb. / Foot	=	Pound Inch (Lb./In.) x 0.083
Lb. / Inch	=	Newton Meter x 8.850	Lb. / Foot	=	Newton Meter x 0.737
Newton Meter	=	Pound Inch (Lb./In.) x 0.113	Newton Meter	=	Pound Foot (Lb./Ft.) x 1.356

**NOTE:** See introduction page of each catalog section for specific ratings.  
Please consult Boston Weatherhead for other material torque ratings.

**1-800-PRO-DANA (1-800-776-3262)**

**Our “800” service is provided for your benefit and is available from 8:00 AM to 7:00 PM Monday through Friday Eastern time.**

The Technical Support Group **will** assist you with information relative to:

- Part number interchanges
- Weatherhead part number verification
- Hose, hose ends, and fitting identification based on application information
- Identification of tube and pipe fittings based on description and dimensions
- Applications not listed in current catalogs
- Chemical resistance ratings
- Dimensions
- Coll-O-Crimp hose crimper information, troubleshooting, and replacement parts
- Selection of correct Coll-O-Crimp tooling
- Construction, materials, and properties of hose and fittings
- Weatherhead tools and accessories
- Hose assembly troubleshooting and problem solving
- Referral to a Weatherhead distributor or District Sales Manager

The Technical Support Group **cannot** respond to the following:

- Transfer of calls to another department or the warehouse
- Inventory status
- Backorders
- Pricing and placing orders
- Literature orders
- Competitive pricing

**We appreciate the opportunity to provide these services to you.  
Your comments and suggestions are welcome.**

**NO PRODUCT LISTED IN THIS CATALOG HAS BEEN CERTIFIED  
FOR AVIATION USE.**

**This catalog and all information herein supersede all previous Weatherhead  
catalogs and information material.**



## A:

**abrasion:** external damage to a hose assembly caused by its being rubbed on a foreign object; a wearing away by friction.

**ABS:** Air-Brake Swivel

**absorption:** regarding hose, the process of taking in fluid. Hose materials are often compared with regard to relative rates and total amounts of absorption as they pertain to specific fluids.

**acid resistant:** having the ability to withstand the action of identified acids within specified limits of concentration and temperature.

**adapter, adaptor:** 1) fittings of various sizes and materials used to change an end fitting from one type to another type or one size to another. (i.e., a male SAE to male pipe adapter is often attached to a female SAE to create a male end union fitting); 2) the grooved portion of a cam & groove coupling.

**adhesion:** the strength of bond between cured rubber surfaces or between a cured rubber surface and a non-rubber surface.

**adhesive:** a material which, when applied, will cause two surfaces to adhere.

**ambient/atmospheric conditions:** The surrounding conditions, such as temperature, pressure, and corrosion, to which a hose assembly is exposed.

**anchor:** a restraint applied to eliminate motion and restrain forces.

**annular:** refers to the convolutions on a hose that are a series of complete circles or rings located at right angles to the longitudinal axis of the hose (sometimes referred to as "bellows").

**anodize, anodized:** an electrolytic process used to deposit protective or cosmetic coatings in a variety of colors on metal, primarily used with aluminum.

**ANSI:** American National Standards Institute.

**Application working pressure:** unique to customer's application. See pressure, working.

**armor:** a protective cover slid over and affixed to a hose assembly; used to prevent over bending or for the purpose of protecting hose from severe external environmental conditions such as hot materials, abrasion or traffic.

**assembly:** a general term referring to any hose coupled with end fittings of any style attached to one or both ends.

**ASTM:** American Society for Testing and Materials.

**axial movement:** compression or elongation along the longitudinal axis.

## B:

**backing:** a soft rubber layer between a hose tube and/or cover and carcass to provide adhesion.

**barb:** the portion of a fitting (coupling) that is inserted into the hose, usually comprised of two or more radial serrations or ridges designed to form a redundant seal between the hose and fitting.

**barbed and ferrule fitting:** a two-piece hose fitting comprised of a barbed insert (nipple), normally with peripheral ridges or backward-slanted barbs, for inserting into a hose and a ferrule, usually crimped or swaged.

**Barb-Tite™:** a line of low pressure push-on brass hose end fittings that is a Trademark of Dana Corporation.

**bend radius:** the radius of a bent section of hose measured to the innermost surface of the curved portion.

**bend radius, minimum:** the smallest radius at which hose or tubing can be used. For Metal Hose: the radius of a bend measured to the hose centerline, as recommended by the manufacturer.

**blister:** a raised area on the surface or a separation between layers usually creating a void or air-filled space in a vulcanized article.

**body wire:** normally a round or flat wire helix embedded in the hose wall to increase strength or to resist collapse.

**bore:** (1) an internal cylindrical passageway, as of a tube, hose or pipe; (2) the internal diameter of a tube, hose, or pipe.

**braid:** the woven portion of a hose used as reinforcement to increase pressure rating and add hoop strength. Various materials such as polyester, cotton or metal wire are used. A hose may have one or more braids, outside or between layers of hose material.

**braided ply:** a layer of braided reinforcement.

**brand:** a mark or symbol identifying or describing a product and/or manufacturer, that is embossed, inlaid or printed.

**brass:** a family of copper/zinc alloys.

**brazing:** a process of joining metals using a non-ferrous filler metal having a melting point that is lower than the "parent metals" to be joined, typically over +800°F.

**bronze:** an alloy of copper, tin and zinc.

**BSP/BSPT:** British Standard Pipe Parallel / British Standard Pipe Tapered. See Fitting/Coupling - Pipe Thread Fittings.

## C:

**carcass:** the fabric, cord and/or metal reinforcing section of a hose as distinguished from the hose tube or cover.

**chalking:** the formation of a powdery surface condition due to disintegration of surface binder or elastomer by weathering or other destructive environments.

**checking:** the short, shallow cracks on the surface of a rubber product resulting from damaging action of environmental conditions.

**chemical compatibility:** the relative degree to which a material may contact another without corrosion, degradation or adverse change of properties.

**chemical resistance:** the ability of a particular polymer, rubber compound, or metal to exhibit minimal physical and/or chemical property changes when in contact with one or more chemicals

for a specified length of time, at specified concentrations, pressure, and temperature.

**cold flexibility:** relative ease of bending while being exposed to specified low temperature.

**collar:** 1) the portion of a fitting that is compressed by crimping to seal the hose onto the fitting barbs and create a permanent attachment; also called a ferrule. (With field attachable fittings, the lock and seal are accomplished mechanically by the collar without crimping); 2) a raised portion on the hose shank which functions as a connection for a ferrule or other locking device or functions as a hose stop.

**Coll-O-Crimp®:** a line of hydraulic and pneumatic hose, hose end fittings, and fabrication equipment that is a registered trademark of Dana Corporation.

**combustible liquid:** a combustible liquid is one having a flash point at or above +100°F (37.8°C).

**compound:** the mixture of rubber or plastic and other materials, which are combined to give the desired properties when, used in the manufacture of a product.

**compression fitting:** see fitting/coupling - Compression

**conductive:** the ability to transfer electrical potential.

**configuration:** the combination of fittings on a particular assembly.

**convoluted:** description of hose or innercore having annular or helical ridges formed to enhance flexibility.

**core:** the inner portion of a hose, usually referring to the material in contact with the medium.

**corrosion:** the process of material degradation by chemical or electrochemical means.

**corrosion resistance:** ability of metal components to resist oxidation.

**corrugated hose:** hose with a carcass fluted, radially or helically, to enhance its flexibility or reduce its weight.

**coupling:** a frequently used alternative term for hose end fitting.

**cover:** the outer component usually intended to protect the carcass of a product.

**CPE:** chlorinated polyethylene, a rubber elastomer.

**cracking:** a sharp break or fissure in the surface, generally caused by strain and environmental conditions.

**crimp diameter:** the distance across opposite flats after crimping.

**crimp/crimping:** a hose end fitting attachment method utilizing a number of dies mounted in a radial configuration. The dies close perpendicular to the hose and fitting axis, compressing the collar, ferrule, or sleeve around the hose.

**cure:** the act of vulcanization. See vulcanization.

**cut off factor:** the hose length to be subtracted from the overall assembly length that allows for the hose coupling end connection extension beyond the end of the hose.

## D:

**date code:** any combination of numbers, letters, symbols or other methods used by a manufacturer to identify the time of manufacture of a product.

**deburr:** to remove ragged edges from the inside diameter of a hose end.

**design factor:** a ratio used to establish the working pressure of the hose, based on the burst strength of the hose.

**DOT:** Department of Transportation.

**DIN:** Deutsche Industrie Norme.

**duplex assembly:** an assembly consisting of two hose assemblies-one inside the other, and connected at the ends; also known as "jacketed assemblies."

**durometer:** an instrument for measuring the hardness of rubber and plastic compounds.

## E:

**eccentricity:** the condition resulting from the inside and outside diameters not having a common center.

**effusion:** the escape, usually of gases, through a material. See permeation.

**elastic limit:** the limiting extent to which a body may be deformed and yet return to its original shape after removal of the deforming force.

**elastomer:** any one of a group of polymeric materials, usually designated thermoset, such as natural rubber, or thermoplastic, which will soften with application of heat.

**elongation:** the increase in length expressed numerically as a percentage of the initial length.

**ERMETO™:** a steel fitting product trademarked by Dana Corporation.

**endurance test:** a service or laboratory test, conducted to product failure, usually under normal use conditions.

**EPDM:** Ethylene Propylene Diene Monomer; an elastomer.

**extrude/extruded/extrusion:** forced through the shaping die of an extruder; extrusion may have a solid or hollow cross section.

## F:

**fabric impression:** impression formed on the rubber surface during vulcanization by contact with fabric jacket or wrapper.

**fabricator:** the producer of hose assemblies.

**fatigue:** the weakening or deterioration of a material occurring when a repetitious or continuous application of stress causes strain, which could lead to failure.

**FDA:** United States Food and Drug Administration.

**fire sleeve:** slip-on or integrally extruded sleeve used to retard the effects of fire in certain applications; most often made with

silicone and/or ceramic fiber.

**fitting/coupling:** a device attached to the end of the hose to facilitate connection. The following is only a partial list of types of fittings available-

**Compression Fitting** - a fitting style that seals on a mating tube by compressing an internal ferrule against the tube O.D..

**Field Attachable Fitting** - a fitting designed to be attached to hose without crimping or swaging. This fitting is not always a reusable type fitting.

**Flange Style Fittings** - pipe flanges and flanged fitting standards are listed under ANSI B16.5. Flanges are rated for pressure and listed as "American Class 150, 300, 400, 600, 900, 1,500 or 2,500". Pressure-Temperature ratings can be obtained by consulting the ANSI specification or ASME B16.5 (American Society of Mechanical Engineers). Designs vary by neck and face style, or other dimensional changes based on use. Various finishes or grooves may be applied to the face for sealing on a gasket or o-ring. Bolt holes and other dimensions are per the ANSI standard.

**Inverted Flare Fitting** - a fitting consisting of a male or female nut, trapped on a tube by flaring the end of the tube material to either 37° or 45°.

**JIC Fittings** - joint Industrial Council (no longer in existence). An engineering group that established an industry standard fitting design incorporating a 37° mating surface, male and female styles. These standards are now governed by SAE.

**O-ring Fittings** - a fitting that seals by means of an elastomeric ring of a specified material.

**Pipe Thread Fittings** -

NPT - National Pipe Taper. Pipe thread per ANSI B1.20.1

NPTF - National Pipe Tapered for Fuels.  
(Same as above except dry-seal per ANSI B1.20.3)

NPSH - National Pipe Straight Hose per ANSI B1.20.7

NPSM - National Pipe Straight Mechanical.  
Straight thread per ANSI B1.20.1

NPSL - National Pipe Straight Loosefit per ANSI B1.20.1

BSPP, BSPT - British Standard Pipe  
Parallel, British Standard Pipe Taper. BS21

**Quick Connect Fitting** - a fitting designed to quickly connect and disconnect. These fittings come in many styles and types.

**Split Flange Fitting** - a fitting consisting of a flange retainer and a flange of two halves. This design allows the flanges to be installed after the retainer has been attached to the hose, making the flange reusable. SAE Code 61 and 62.

**Tube Fitting** - a hose fitting of which the mating end conforms to a tube diameter. The mate or male end of a compression fitting.

**flammable gases/liquid/media:** a flammable gas, including liquefied gas, is one having a closed cup flash point below +100°F (+37.8°C) and a vapor pressure greater than 25 psi. (174.2 KPa).

**flex cracking:** a surface cracking induced by repeated bending and straightening.

**flow rate:** a volume of media being conveyed in a given time period.

**fluid:** a gas or liquid medium.

**fluorocarbon:** an organic compound containing fluorine directly bonded to carbon. The ability of the carbon atom to form a large variety of structural chains gives rise to many fluorocarbons and fluorocarbon derivatives.

**FOR-SEAL™:** a product name for a hose end configuration using an o-ring sealing method, trademarked by Dana Corporation.

**G:**

**GPM:** gallons per minute.

**H:**

**heat resistance:** the property or ability to resist the deteriorating effects of elevated temperatures.

**helix:** a shape formed by spiraling a wire or other reinforcement around the cylindrical body of a hose; typically used in suction hose.

**hose:** a flexible conduit consisting of a tube, reinforcement, and usually an outer cover.

**hydrostatic testing:** the use of liquid pressure to test a hose or hose assembly for leakage, twisting, and/or hose change-in-length.

**Hytrel®:** a DuPont registered trademark.

**I:**

**I.D.:** the abbreviation for inside diameter.

**identification yarn:** a yarn of single or multiple colors, usually embedded in the hose wall, used to identify the manufacturer.

**impression:** a design formed during vulcanization in the surface of a hose by a method of transfer, such as fabric impression or molded impression.

**impulse:** an application of force in a manner to produce sudden strain or motion, such as hydraulic pressure applied in a hose.

**innertube:** the innermost layer of a hose; the hose material in contact with the medium.

**insert:** optional term for nipple. See nipple.

**interlocking clamp:** a clamp which engages the fitting in a manner which prevents the clamp from sliding off the fitting, typically

a bolt or U-bolt style with interlocking fingers which engage an interlock ring on the fitting.

**interlocking ferrule:** a ferrule, which physically attaches to the fitting preventing the ferrule from sliding off the fitting.

**ISO:** International Organization for Standardization.

#### J:

**jacket:** a seamless tubular braided or woven ply generally on the outside of a hose.

**JIC:** see fitting/coupling-JIC.

#### K:

**kinking:** a temporary or permanent distortion of the hose induced by bending beyond the minimum bend radius.

#### L:

**layline:** the line of printed information that runs parallel on the side of a manufactured hose giving details such as part number, PSI rating, hose size and manufacturing data.

**layer:** a single thickness of rubber or fabric between adjacent parts.

**loop installation:** the assembly is installed in a loop or "U" shape, and is most often used when frequent and/or large amounts of motion are involved.

**LPG, LP Gas:** the abbreviation for liquefied petroleum gas.

#### M:

**MAWP:** see pressure, maximum allowable working.

**manufacturer's identification:** a code symbol used on or in some hose to indicate the manufacturer.

**media, medium:** the substance(s) being conveyed through a system.

#### N:

**NAHAD:** the abbreviation for the National Association of Hose & Accessories Distributors.

**Neoprene®:** a registered trademark of DuPont.

**nipple:** the internal member or portion of a hose fitting.

**nitrile rubber (NB/Buna-N):** a family of acrylonitrile elastomers used extensively for industrial hose.

**nominal:** a size indicator for reference only.

**nomograph:** a chart used to compare hose size to flow rate to recommended velocity.

**non-conductive:** the inability to transfer an electrical charge.

**NPT/NPTF:** abbreviation for national pipe threads. See fitting/coupling - Pipe Thread Fittings.

**nylon:** a family of polyamide materials.

#### O:

**OAL:** see overall length

**O.D.:** the abbreviation for outside diameter.

**OE/OEM:** original equipment manufacturer.

**oil resistance:** the ability of the materials to withstand exposure to oil.

**oil swell:** the change in volume of a rubber article resulting from contact with oil.

**operating conditions:** the pressure, temperature, motion, and environment to which a hose assembly is subjected.

**o-ring fitting:** see fitting/coupling, O-Ring.

**overall length (OAL):** the total length of a hose assembly, which consists of the free hose length plus the length of the coupling(s).

**oxidation:** the reaction of oxygen on a material, usually evidenced by a change in the appearance or feel of the surface or by a change in physical properties.

**ozone cracking:** the surface cracks, checks or crazing caused by exposure to an atmosphere containing ozone.

**ozone resistance:** the ability to withstand the deteriorating effects of ozone (generally cracking).

#### P:

**permanent fitting:** the type of fitting which, once installed, may not be removed for re-use.

**permeation:** the process of migration of a substance into and through another, usually the movement of a gas into and through a hose material; the rate of permeation is specific to the substance, temperature, pressure and the material being permeated.

**pin pricked:** perforations through the cover of a hose to vent permeating gases.

**pitch:** 1) the distance from one point on a helix to the corresponding point on the next turn of the helix, measured parallel to the axis; 2) the distance between the two peaks of adjacent corrugation or convolution.

**plating:** a material, usually metal, applied to another metal by electroplating, for the purpose of reducing corrosion; typically a more noble metal such as zinc is applied to steel.

**ply:** an individual layer in hose construction.

**polymer:** a macromolecular material formed by the chemical combination of monomers, having either the same or different chemical compositions.

**pressure:** force ÷ unit area. For purposes of this document, refers to PSIG (pounds per square inch gauge).

**pressure drop:** the measure of pressure reduction or loss over a specific length of hose.

**pressure, burst:** the pressure at which rupture occurs.

**pressure, maximum allowable working:** the maximum pressure at which a hose or hose assembly is designed to be used.

**pressure, working:** the maximum pressure to which a hose will be subjected, including the momentary surges in pressure, which can occur during service. Abbreviated as WP.

**psi (PSI):** pounds per square inch.

**PTFE:** polytetrafluoroethylene, a high molecular weight fluoroplastic polymer with carbon atoms shielded by fluorine atoms having very strong inter atomic bonds, giving it chemical inertness.

**Push > Connect™:** (Push > Connect™ Metric, Push > Connect™ Flow Controls, Push > Connect™ Plus) A Reusable, easy to assemble fitting recommended on compressed air, lubrication, and pneumatic instrumentation applications. Use with approved tubing material.

**PVC:** polyvinyl chloride. A low cost thermoplastic material typically used in the manufacture of industrial hoses. The operating temperature range is -500°F to +1750°F (-295.5°C to +954.4°C).

#### Q:

**Quick > Connect™:** A reusable easy to assemble air brake fitting used on NT100 series tubing. This fitting meets D.O.T. performance requirements.

#### R:

**reinforcement:** the strengthening members, consisting of either fabric, cord, and/or metal, of a hose. See ply.

**reusable fitting/coupling:** see fitting/coupling, Field Attachable Fittings.

**RhinoHide®:** a product's name for an abrasion resistant covered hydraulic hose that is a registered trademark of Dana Corporation.

**RMA:** The Rubber Manufacturers Association, Inc.

#### S:

**SAE:** Society of Automotive Engineers.

**shank:** that portion of a fitting, which is inserted into the bore of a hose.

**skive:** the removal of a short length of cover and/or tube to permit the attachment of a fitting directly over the hose reinforcement.

**sleeve:** a metal cylinder, which is not physically attached to the fitting, for the purpose of forcing the hose into the serrations of the fitting.

**smooth bore:** a term used to describe the type of innercore in a hose.

**specification:** a document setting forth pertinent details of a product.

**spiral:** a method of applying reinforcement in which there is not interlacing between individual strands of the reinforcement.

**spring guard:** a helically wound component applied internally or externally to a hose assembly, used for strain relief, abrasion resistance, collapse resistance.

**standard:** a document, or an object for physical comparison, for defining product characteristics, products, or processes, prepared by a consensus of a properly constituted group of those substantially affected and having the qualifications to prepare the standard for use.

**static wire:** wire incorporated in a hose to conduct static electricity.

**stem:** see nipple.

**surge (spike):** a rapid and transient rise in pressure.

**swelling:** an increase in volume or linear dimension of a specimen immersed in liquid or exposed to a vapor.

#### T:

**Teflon®:** a registered trademark of E.I. DuPont. See PTFE, FEP and PFA.

**tube:** the innermost continuous all-rubber or plastic element of a hose.

**tube fitting:** see fitting/coupling-Tube.

**tubing:** a non-reinforced, homogeneous conduit, generally of circular cross-section.

#### V:

**vacuum resistance:** the measure of a hoses ability to resist negative gauge pressure.

**vibration:** amplitude motion occurring at a given frequency.

**viscosity:** the resistance of a material to flow.

**vulcanization:** a process during which a rubber compound, through a change in its chemical structure, improves or extends elastic properties over a greater range of temperature.

#### W:

**weathering:** the surface deterioration of a hose cover during outdoor exposure, as shown by checking, cracking, crazing and chalking.

**wire reinforced:** a hose containing wires to give added strength, increased dimensional stability; crush resistance. See reinforcement.

**working temperature:** the temperature range of the application, may include the temperature of the fluid conveyed or the environmental conditions the assembly is exposed to in use.

**WP:** the abbreviation for working pressure.

The preceding Glossary of Terms, as utilized in the hose industry, includes some definitions from The Hose Handbook, published by the Rubber Manufacturers Association.

A55SCUx.....	77	BA-56X.....	241	C5755x.....	175
A555.....	113	BA-84.....	240	C5880x.....	166
A555P.....	115	BA-84X.....	240	C5924x.....	162
A555S.....	113	BF-40.....	237	C9200.....	127
A556P.....	115	BF-40X.....	236, 237, 238, 243, 245	C9240.....	127
A557MCUx.....	77	BF-41.....	237	C-5X.....	249
A557SCUx.....	77	BF-42.....	237	C-15X.....	232, 233
A655.....	113	BF-43.....	237	C-63X.....	232, 233, 235, 249
A655S.....	113	BL-456.....	247	C-632X.....	233, 234
A660.....	113	BL-456X.....	245, 247	CA-10X.....	246
A664.....	121	C3059x.....	141	CA-130.....	246
A690.....	113	C3069x.....	143	CA-230.....	246
A690P.....	115	C3109x.....	142	CA-631.....	235
A690S.....	113	C3159x.....	141	CA-631CO.....	235
A694.....	121	C3169x.....	141	CA-632.....	233, 234
A694S.....	121	C3179x.....	141	CA-632CO.....	234
A735.....	113	C3209x.....	142	CB-63X.....	233
A6690.....	113	C3239x.....	143, 205	CD-15.....	232, 233
A6690S.....	113	C3249x.....	143, 204	CD-15D.....	232
A6754.....	121	C3269x.....	142, 204	CL-16-1.....	231, 235
A6754S.....	121	C3309x.....	143	CL-16-2.....	231, 244
A6755.....	113	C3359x.....	144	CL-16-3.....	93, 231, 242
A6755S.....	113	C3409x.....	145	CL-434.....	231, 250
A6759.....	121	C3459x.....	146, 211	CL-490.....	41, 47, 106, 231, 234, 235
A6760.....	113	C3469x.....	146, 211	CL-491.....	99, 231
A6760P.....	115	C3509x.....	145	CL-492.....	231
A6760S.....	113	C3529x.....	147	CL-493.....	231
A6763.....	113	C3559x.....	144	CL-494.....	231
A6763S.....	113	C3609x.....	147	CL-496.....	80, 231
A6764.....	121	C3709x.....	147	CL-497.....	231, 242
A6764S.....	121	C3759x.....	148	CL-498.....	60, 231
A6765.....	113	C3959x.....	148	CL-499.....	231, 239
A6765S.....	113	C5015x.....	162	CL-500.....	53, 231
A6769.....	121	C5105x.....	161	CL-501.....	231
A6769S.....	121	C5115x.....	161	CL-502.....	231, 249
A6770.....	113	C5125x.....	161	CL-503.....	84, 231, 243
A6774.....	121	C5129x.....	162	DC-121.....	239
A6775.....	113	C5165x.....	161, 184	FA-100.....	248
A6775S.....	113	C5165x-MM.....	161, 249	FA-100-CO.....	248
A6779.....	121	C5205x.....	164	FC-16X.....	232, 235, 239, 242, 243, 244
A6779S.....	121	C5216x.....	167, 207	FC-161.....	235
A6793.....	120	C5229x.....	162	FH-15X.....	232, 244, 248, 250
A6845.....	113	C5255x.....	164	FL-310.....	250
A6845S.....	113	C5256x.....	167	FL-310X.....	250
A6855.....	113	C5275x.....	164	FS-100.....	231
A6855S.....	113	C5305x.....	163	FS-200.....	159, 231
A6860.....	113	C5306x.....	163	FS-300.....	231
A6860P.....	115	C5314x.....	203	FS-500.....	231
A6860S.....	113	C5315x.....	165, 206	FS-501.....	231, 247
AB-8.....	246	C5316x.....	165, 206	FS-800.....	99, 231, 244
AB-8L.....	246	C5325x.....	163	FS-900.....	93, 231
AB-8X.....	246	C5355x.....	167	FS-1000.....	80, 231
AB-9.....	246	C5356x.....	168	FS-1600.....	190, 231
AB-9L.....	246	C5365x.....	169, 207	FS-2000.....	140, 231
AB-9X.....	246	C5405x.....	170	FS-2100.....	60, 231
AB-28.....	244	C5425x.....	171	FS-2400.....	149, 231
AB-45.....	244	C5455x.....	172	FS-2500.....	250
AB-140.....	242	C5505x.....	169	FS-3300.....	84, 231
AB-1400.....	242	C5506x.....	172	FS-SA-1.....	245
B735.....	113	C5515x.....	173, 209	FS-SA-2.....	245
BA-24.....	241	C5525x.....	171	H05703.....	247
BA-24X.....	241	C5605x.....	176	H05704.....	247, 250
BA-28.....	241	C5655x.....	177	H05705.....	247, 250
BA-28X.....	241	C5705x.....	174	H05706.....	247, 250
BA-38.....	241	C5706x.....	175	H06904.....	248
BA-38X.....	241	C5707x.....	177	H06906.....	248
BA-48.....	241	C5715x.....	178, 212	H06908.....	248
BA-48X.....	241	C5716x.....	176, 212		
BA-56.....	241	C5726x.....	176		

H06910.....	248	PT24004.....	34	SFK62-32.....	180
H10104.....	247	PT24044.....	34	SH-53.....	231
H10105.....	247	PT24005.....	34	SJ308.....	130, 241
H10106.....	247	PT24006.....	34	SJ312.....	130, 241
H16606.....	248	PT24008.....	34	SJ320.....	130, 241
H16608.....	248	PT24010.....	34	SJ330.....	130, 241
H33806.....	248	PT24012.....	34	SJ340.....	130, 241
HA-574.....	247	PT24016.....	34	SJ351.....	130, 241
HC-574X.....	247	QC-18.....	243	SJ360.....	130, 241
HD-1X.....	248	QC-18X.....	243	SS-85.....	236
M7629x.....	185, 249	QC-180.....	243	SS-86.....	236
M7630x.....	185	QC-1800.....	243	SS-87.....	236
M9600x.....	188, 249	RG-24.....	224	SS-88.....	237
M9700x.....	185, 249	S306.....	130, 240	T-100.....	228
M9800x.....	188, 249	S308.....	130, 240	T-104.....	228
M41157x.....	126	S310.....	130	T-105.....	228
MA-100.....	249	S312.....	130, 240, 241	T-106.....	228
MA-200.....	250	S320.....	130, 240, 241	T-107.....	228
MB5315x.....	188, 249	S330.....	130, 240, 241	T-108.....	228
MB5515x.....	189, 249	S340.....	130, 240, 241	T-125B.....	227
MB7629x.....	189	S351.....	130, 240, 241	T-135.....	227
MB7630x.....	189	S360.....	130, 240, 241	T-135B.....	227
MC3069x.....	187	S372.....	130, 240	T-138.....	227
MC3159x.....	186	S408.....	130	T-138B.....	227
MC3309x.....	186	S412.....	130, 240, 241	T-139.....	226
MC5019x.....	166, 183	S420.....	130, 240, 241	T-139P.....	226
MC5205x.....	187, 249	S430.....	130, 240, 241	T-140.....	226
MC5206x.....	183, 249	S440.....	130, 240, 241	T-141.....	226
MC5207x.....	183, 249	S451.....	130, 240, 241	T-142.....	226
MC5208x.....	183, 249	S460.....	130, 240, 241	T-143.....	226
MC5315x.....	184, 249	S512.....	130, 240, 241	T-144.....	226
MC5405x.....	189, 249	S520.....	130, 240, 241	T-145.....	226
MC5515x.....	185, 249	S530.....	130, 240, 241	T-146.....	226
MH7105x.....	182, 249, 250	S540.....	130, 240, 241	T-147.....	226
ML7105x.....	182, 249, 250	S551.....	130, 240, 241	T-148.....	226
MTP16004.....	34	S560.....	130, 240, 241	T-149.....	226
MTP16005.....	34	S612.....	130, 241	T-150.....	226, 229
MTP16006.....	34	S620.....	130, 241	T-151.....	226
MTP16008.....	34	S630.....	130, 241	T-152.....	226
MTP16010.....	34	S640.....	130, 241	T-152P.....	226
MTP16012.....	34	S651.....	130, 241	T-191.....	227, 243
NT10002.....	33, 245	S660.....	130, 241	T-191B.....	227
NT10025.....	33	SA-1.....	245	T-200.....	228
NT10003.....	33	SA-2.....	245	T-210.....	229
NT10004.....	33, 245	SB308.....	130, 241	T-220.....	229
NT10005.....	33	SB312.....	130, 241	T-221.....	229
NT10006.....	33, 245	SB320.....	130, 241	T-345.....	229
NT10008.....	33	SB330.....	130, 241	T-345K.....	229
NT10010.....	33	SB340.....	130, 241	T-346x.....	229
NT10012.....	33	SB351.....	130, 241	T-372.....	228
PC-48.....	239	SB360.....	130, 241	T-373.....	228
PD-15.....	232	SC308.....	130, 241	T-374.....	228
PD-49.....	232, 233, 249	SC312.....	130, 241	T-375.....	228
PD-75.....	232, 233, 249	SC320.....	130, 241	T-376.....	228
PD-95.....	232	SC330.....	130, 241	T-378.....	228
PT20004.....	33	SC340.....	130, 241	T-450-3.....	223
PT20044.....	33	SC351.....	130, 241	T-460-2.....	223
PT20005.....	33	SC360.....	130, 241	T-560.....	231
PT20006.....	33	SFK-8.....	179	T-560-1.....	231
PT20008.....	33	SFK-12.....	179	T-560-2.....	231
PT20010.....	33	SFK-16.....	179	T-560-3.....	231
PT20012.....	33	SFK-20.....	179	T-560-4.....	231
PT20016.....	33	SFK-24.....	179	T-560-5.....	231
PT23002.....	33	SFK-32.....	179	T-560-6.....	231
PT23003.....	33	SFK62-8.....	180	T-560-7.....	231
PT23004.....	33	SFK62-12.....	180	T-560-8.....	231
PT23005.....	33	SFK62-16.....	180	T-562.....	230
PT23006.....	33	SFK62-20.....	180	T-570.....	223
PT23008.....	33	SFK62-24.....	180	T-570-1.....	223

T-570-4.....	223	TF3805x.....	148	08U.....	250
T-570-6.....	223	TF3959x.....	148	10U.....	250
T-570-8.....	223	TF5355x.....	167	12U.....	250
T-570-12.....	223	TF5356x.....	168	16U.....	250
T-570-16.....	223	TF5365x.....	169, 207	05703B-102.....	234
T-571-4.....	223	TF5375x.....	168	05704B-102.....	234, 250
T-571-6.....	223	TF5405x.....	170	05704B-104.....	234, 250
T-571-8.....	223	TF5406x.....	173	05704B-C02.....	234, 250
T-571-12.....	223	TF5425x.....	171	05705B-102.....	234, 250
T-571-16.....	223	TF5435x.....	171	05705B-104.....	234, 250
T-1010.....	228	TF5455x.....	172	05705B-C02.....	234, 250
T-1022.....	229	TF5505x.....	169	05705B-C04.....	234, 250
T-1037.....	227	TF5506x.....	172	05705B-1560.....	234, 250
T-1290.....	229	TF5515x.....	173, 209	05705B-1561.....	234, 250
T-1295.....	230	TF5515x-L.....	174, 209	05706B-102.....	234, 250
T-1422R.....	226, 229	TF5515x-LL.....	174, 210	05706B-104.....	234, 250
T-1430.....	226	TF5525x.....	171	05706B-106.....	234, 250
T-3710.....	228	TF5605x.....	176	05706B-C02.....	234, 250
T-3712.....	228	TF5655x.....	177	05706B-C04.....	234, 250
T-3716.....	228	TF5705x.....	174	05706B-1568.....	234, 250
T-5002.....	224	TF5706x.....	175	05706B-1570.....	234, 250
T-5003.....	224	TF5707x.....	177	05710B-106.....	123
T-5004.....	224	TF5715x.....	178, 212	05710B-108.....	123
T-5005.....	224	TF5716x.....	176, 212	05710B-C06.....	126
T-5006.....	224	TF5725x.....	177	05712B-108.....	123
T-5008.....	224	TF5726x.....	176	5X6 PB.....	231
T-5010.....	224	TF5755x.....	175	6X10 PB.....	231
T-5012.....	224	TF5805x.....	175	8X12 PB.....	231
T-5016.....	224	TF5955x.....	178	8x251.....	179
T-5020.....	224	TH7008.....	223	8x252.....	179, 180, 224
T-5024.....	224	TH7010.....	223	8x254.....	179, 180
T-5032.....	224	TH7012.....	223	8x262.....	180
T-5102.....	224	TH7014.....	223	8x853.....	179
T-5103.....	224	TH7016.....	223	8x863.....	180
T-5104.....	224	TH7020.....	223	12x251.....	179
T-5105.....	224	TH7025.....	223	12x252.....	179, 180, 224
T-5106.....	224	TH7030.....	223	12x254.....	179, 180
T-5108.....	224	TL7008.....	223	12x262.....	180
T-5110.....	224	TL7010.....	223	12x853.....	179
T-5112.....	224	TL7012.....	223	12x863.....	180
T-5116.....	224	TL7015.....	223	16x251.....	179
T-5120.....	224	TL7018.....	223	16x252.....	179, 180, 224
T-5124.....	224	TL7022.....	223	16x254.....	179, 180
T-5132.....	224	TL7028.....	223	16x262.....	180
T-7002.....	223	TP16002.....	34	16x853.....	179
T-7003.....	223	TP16025.....	34	16x863.....	180
T-7004.....	223	TP16004.....	34	20x251.....	179
T-7005.....	223	TP16005.....	34	20x252.....	179, 180, 224
T-7006.....	223	TP16006.....	34	20x254.....	179, 180
T-7008.....	223	TP16008.....	34	20x262.....	180
T-7010.....	223	W05465.....	144, 244	20x853.....	179
T-7012.....	223	W05498.....	144	20x863.....	180
T-7014.....	223	W05499.....	144	24x251.....	179
T-7016.....	223	W05730.....	144	24x252.....	179, 180, 224
T-7020.....	223	W1206.....	220	24x254.....	179
T-7024.....	223	W1212.....	220	24x262.....	180
T-7032.....	223	W1512.....	220	24x264.....	180
TA-1002.....	225, 249	W14630.....	220, 244	24x853.....	179
TA-1004.....	225	W15310.....	103, 120, 242, 244	24x863.....	180
TF3359x.....	144	W17709.....	144	32x251.....	179
TF3409x.....	145	W20332.....	103, 121	32x252.....	179, 180, 224
TF3459x.....	146, 211	W21204.....	144	32x254.....	179, 180
TF3509x.....	145	W23464.....	144	32x262.....	180
TF3529x.....	147	W76150.....	220, 244	32x264.....	180
TF3559x.....	144	W79850.....	220, 244	32x853.....	179
TF3569x.....	146, 208	W79851.....	220, 244	32x863.....	180
TF3609x.....	147	W-8022.....	41, 47, 106, 231	39x.....	42
TF3709x.....	147	04U.....	250	40x.....	42
TF3759x.....	148	06U.....	250	41x.....	42, 234, 235



42x.....	42, 234	185.....	116	1109x.....	67
43x.....	43	190.....	116	1109x-M.....	72
44x.....	46	202x.....	38, 234, 235, 236	1110x.....	42
45x.....	46	230.....	116	1129x.....	67
46x.....	43	252x.....	38, 234	1129x-MRP.....	72
48x.....	42, 234, 235	270.....	116, 234	1150x.....	126
49x.....	45, 234, 235	302x.....	37, 130, 234, 235, 236, 237, 238	1161x.....	67
50x.....	45	320.....	115	1161x-M.....	72
51x.....	46	325.....	115	1162x.....	68, 239
54x.....	43	330.....	115	1162x-M.....	72
55x.....	45	352x.....	38	1164x.....	70, 239
56x.....	46	402x.....	39, 234, 235, 236	1164x-M.....	74
59x4.....	44, 127	452x.....	39	1165x.....	69, 239
60x.....	48, 120, 234, 235, 236	502x.....	39	1165x-M.....	74
61x.....	48, 234, 235, 236	530.....	115	1166x.....	69, 239
62x.....	49, 234, 235, 236	537.....	121	1166x-M.....	73
63x.....	50	552x.....	40	1168Px.....	78
64x.....	52, 234	601x.....	55, 245	1168x.....	78, 239
65x.....	51	602x.....	40	1168x-M.....	73
66x.....	50, 234	611x.....	55, 245	1169Px.....	79
68x.....	49, 234, 235, 236	621x.....	56, 245	1169x.....	69, 70
69x.....	51, 234, 235, 236	630.....	115	1169x-M.....	74
70x.....	51	632.....	121	1169x-MS.....	74
71x.....	52	631x.....	57	1169x-S.....	70, 239
72x.....	52	641x.....	58	1171Px.....	79
74x.....	49, 50	651x.....	57	1171x-M.....	75
76x.....	52	652x.....	40	1171x-S.....	70, 239
100x.....	37, 234	661x.....	57, 245	1172Px.....	79
105x.....	37, 113, 128, 234, 235, 236, 237, 238	681x.....	56, 245	1172x-M.....	75
108.....	116, 234, 235	691x.....	58, 245	1172x-S.....	71, 239
110.....	119, 239	695.....	115	1174x.....	68, 239
111.....	119, 239	700.....	115	1174x-M.....	72
112.....	119, 239	701x.....	58	1180x.....	68
113.....	119, 239	702.....	121	1180x-M.....	72
114.....	119, 239	702x.....	39	1181x.....	71
115.....	119, 239	703.....	121	1182x.....	71
116.....	119, 239	705.....	117	1183x.....	71
117.....	119, 239	711x.....	59	1184x.....	71
118.....	119	721x.....	59	1185x.....	71
119.....	119	741x.....	57	1202x.....	62
120.....	117	752x.....	40	1229x.....	61
121.....	119	761x.....	59	1260x.....	61
122.....	119	0102x.....	49, 56	1260x-B.....	61
123.....	119	1062x.....	81	1261x.....	61
124.....	119	1064x.....	83	1261x-A.....	62
125.....	119	1065x.....	82	1261x-B.....	62
126.....	119	1066x.....	81	1262x.....	62
127.....	119	1067x.....	82	1262x-S.....	63
128.....	119	1068x.....	81	1264x.....	65
130.....	116	1069x.....	82	1265x.....	64
131x.....	37	1070x.....	82	1266x.....	63
135.....	116, 234, 235, 239	1071x.....	83	1268x.....	63
140.....	116, 234	1072x.....	83	1269x.....	64
145.....	103, 116, 234, 235, 239, 242, 244	1073x.....	81	1270x.....	64
150.....	117	1074.....	128	1271x.....	65
162x.....	49	1074x.....	82	1272x.....	65
163x.....	50	1075x.....	83	1274x.....	62, 63, 64
164x.....	52	1077x.....	83	1274x-S.....	64
165x.....	51	1078x.....	81	1277x.....	65
166x.....	50	1079x.....	81	1340.....	103, 110
168x.....	49	1100x.....	127	1341.....	103, 110
169x.....	51	1105x.....	67	1342.....	103, 110
170x.....	51	1105x-M.....	72	1343.....	103, 110
171x.....	52	1107x.....	68	1344.....	103, 109
172x.....	52	1107x-M.....	73	1345.....	103, 109
174x.....	50	1108Px.....	78	1346.....	103, 109
176x.....	52	1108x.....	68, 69	1351.....	103, 109
		1108x-M.....	73	1360x.....	100, 244
				1361x.....	100, 244

1362x.....	100, 244	1522.....	38, 44, 125	1874x.....	86, 243
1364x.....	102	1529x.....	137	1877x.....	92
1365x.....	101	1529Px.....	137	1880x.....	88, 243
1366x.....	101	1531x.....	137	1880x-S.....	88
1368x.....	100, 244	1538.....	234	1883x.....	92
1369x.....	101, 244	1548.....	222, 234	1900.....	138
1369x-L.....	101	1552x9.....	234	1901.....	138
1370x.....	102	1552x10.....	234	1902.....	138
1371x.....	102	1553.....	38, 44, 125	1903.....	138
1372x.....	102	1554.....	38, 44, 125	1906.....	138
1380x.....	101, 244	1561x.....	136	1907.....	138
1382x.....	102	1561Px.....	136	1908.....	138
1390x6.....	244	1562x.....	133	1911.....	138
1391x6.....	244	1562Px.....	133	1912.....	138
1408.....	123	1563.....	38, 44, 125	1913.....	138
1410.....	123	1564x.....	136	1914.....	138
1421-7.....	118	1564Px.....	136	1915.....	138
1421-18.....	118	1565x.....	135	1916.....	138
1421-24.....	118	1565Px.....	135	1917.....	138
1421-32.....	118	1566x.....	134	1918.....	138
1421-60.....	118	1566Px.....	134	1920.....	138
1421-60A.....	118	1568x.....	133	1921.....	138
1422.....	118	1568Px.....	133	1922.....	138
1423.....	118	1569x.....	134	1923.....	138
1424A.....	117	1569Px.....	134	1924.....	138
1425A.....	117	1570x.....	135	1925.....	138
1426A.....	117	1570Px.....	135	1927.....	138
1427.....	118	1571x.....	136	1928.....	138
1428.....	123	1571Px.....	136	1929.....	138
1429.....	123	1572x.....	135	1930.....	138
1432.....	123	1572Px.....	135	1931.....	138
1433.....	118	1574x.....	134	1932.....	138
1437.....	124	1574Px.....	134	1933.....	138
1439.....	124	1584x.....	137	1935.....	138
1440.....	124	1584Px.....	137	1936.....	138
1441.....	128	1596.....	125	1937.....	138
1442.....	129, 234, 238	1597.....	125	1938.....	138
1443.....	129, 234, 238	1611x.....	49, 55, 120	1939.....	138
1444.....	124	1621x.....	56	1940.....	138
1445.....	124	1631x.....	57	1942.....	138
1446.....	124	1641x.....	58	1943.....	138
1447.....	124	1651x.....	57	1944.....	138
1451.....	118	1661x.....	57	1945.....	138
1460x.....	94, 242, 245	1681x.....	56	1946.....	138
1461x.....	94, 242, 245	1691x.....	58	1948.....	138
1462x.....	94, 242, 245	1701x.....	58	1949.....	138
1464x.....	97, 242, 245	1711x.....	59	1950.....	138
1465x.....	96	1721x.....	59	2030x.....	48, 55, 234
1466x.....	95, 242, 245	1741x.....	57	3081x.....	143
1468x.....	95, 242, 245	1761x.....	59	3121x.....	142
1469x.....	96, 242, 245	1800Kx.....	92, 243	3129x.....	107, 234
1469x-L.....	96, 242	1800T.....	92, 243	3150x.....	107, 234, 235
1470x.....	96, 242	1800TRK.....	92, 243	3151x.....	107, 234, 235, 236
1471x.....	97, 242	1829x.....	92	3152x.....	107, 234, 235, 237
1472x.....	97, 242, 245	1861x.....	86	3153x.....	107
1474x.....	95	1862x.....	86, 243	3171x.....	141
1477x.....	97	1864x.....	90	3200x.....	107, 234, 235
1480x.....	95, 242	1865x.....	88	3220x.....	108, 234, 235, 236, 237
1482x.....	98	1866x.....	87	3221x.....	142
1483x.....	98	1868x.....	87, 243	3250x.....	108
1484x.....	98, 242, 245	1869x.....	89	3300x.....	108, 234, 235, 236, 237
1485x.....	98, 245	1869x-L.....	89	3321x.....	143
1502x.....	137	1869x-S.....	90	3325x.....	108, 234, 235
1502Px.....	137	1870x.....	90	3326x.....	109, 234, 235, 237
1512.....	44, 124	1871x.....	91	3327x.....	109, 234, 235
1513.....	44, 125, 127	1871x-S.....	91	3328x.....	109, 234, 235
1514.....	44, 125, 234	1872x.....	91	3329x.....	109
1518.....	38, 44, 125	1872x-S.....	92	3330x.....	109
1521.....	44, 125	1873x.....	86	3331x.....	109

3350x.....	110, 234, 235, 237	6100x.....	105, 127, 234	7267x.....	198
3371x.....	144	6200x.....	105, 234	7305x.....	197
3400x.....	110, 234, 235, 237	6202.....	234, 250	7306x.....	197
3421x.....	145	6203-010.....	246	7315x.....	198, 205
3500x.....	111, 234, 237	6203-016.....	246	7317x.....	197
3521x.....	145	6203-020.....	246	7318x.....	197
3541x.....	147	6203-024.....	246	7325x.....	198
3600x.....	111, 234	6203-036.....	246	7327x.....	198, 205
3621x.....	147	6204-010.....	246	7337x.....	198
3700x.....	111, 234, 235	6204-016.....	246	7355x.....	199
3721x.....	147	6204-020.....	246	7367x.....	199
3750x.....	111, 234, 235	6204-024.....	246	7405x.....	199
3771x.....	148	6204-036.....	246	7417x.....	199
3950x.....	111	6205-004.....	246	741x.....	57
4105x.....	152	6205-006.....	246	7455x.....	199
4129x.....	152	6206-004.....	246	7467x.....	199
4165x.....	152	6206-006.....	246	7502.....	119
4205x.....	143, 154	6300x.....	105	7504.....	119
4213x.....	154, 165	6400x.....	105	7505x.....	199
4229x.....	153	6550x.....	105	7506.....	119
4305x.....	153	6600.....	118	7508.....	119
4307x.....	199	6660.....	117, 234	7509.....	119
4315x.....	153, 204	6700.....	115	7515x.....	200, 210
4316x.....	154, 205	6703.....	115	7517x.....	199
4325x.....	153	6707.....	122, 244	7527x.....	200, 210
4355x.....	155	6708.....	122, 244	7605x.....	200
4365x.....	155, 208	6709.....	122, 244	7617x.....	200
4375x.....	155	6715.....	114	7629x.....	139, 148, 166, 178, 202, 213, 224
4405x.....	156	6719.....	120	7655x.....	200
4505x.....	155	6724.....	120	7667x.....	200
4515x.....	156, 157, 210	6729.....	120	7705x.....	200
4525x.....	156	6737.....	122	7708.....	130
4535x.....	157	6746.....	122	7709.....	130
4629x.....	139, 158, 224	6747.....	122, 244	7705x.....	200
4640x.....	152	6748.....	122, 244	7715x.....	202, 213
4705x.....	157	6749.....	122, 234, 244	7716x.....	201, 212
4715x.....	157, 213	6783.....	117	7717x.....	200
4716x.....	158, 213	6788.....	116	7727.....	128
4726x.....	158	6800.....	114	7727x.....	202, 213
4924x.....	152	6804.....	122	7728x.....	200
4955x.....	158	6805.....	114	7732.....	128
5027x.....	162	6809.....	122, 234	7755x.....	200
5117x.....	161	6810.....	114	7765.....	130
5141x.....	162	6815.....	114	7767x.....	200
5177x.....	161	6820.....	114	7771.....	128
5188.....	130	6824.....	121	7805.....	130
5217x.....	164	6825.....	114	7805x.....	200
5241x.....	162	6828.....	122	7812.....	130
5267x.....	164	6829.....	121, 234	7817.....	128
5317x.....	163	6891.....	120	7818.....	128, 234, 237
5318x.....	163	6892.....	120, 234	7828.....	128, 234, 237
5327x.....	165, 206	6893.....	120	7829.....	128, 234, 237
5337x.....	163	7015x.....	197	7896x.....	37, 128, 130, 234, 236, 237, 238
5367x.....	167	7027x.....	197	7897.....	128, 237
5368x.....	168	7033x.....	203	7898.....	129, 237, 238
5417x.....	170	7105x.....	196	7899.....	129, 238
5467x.....	172	7117x.....	196	7900.....	129, 237, 238
5517x.....	169	7129x.....	197	7901.....	129, 237, 238
5518x.....	172	7141x.....	197	7902.....	129, 238
5527x.....	173, 209	7165x.....	196	7904.....	129, 234, 237, 238
5537x.....	171	7165x-MM.....	182, 249, 250	7905.....	129, 237, 238
5617x.....	176	7176x.....	196	7906.....	129, 234, 237, 238
5667x.....	177	7205x.....	198	7907.....	130
5717x.....	174	7217x.....	198	7908.....	128, 234, 237
5718x.....	175	7229x.....	197	7909.....	128
5719x.....	177	7237x.....	203	7910.....	128, 237
5737x.....	177	7238x.....	203	7911.....	128, 237
5767x.....	175	7241x.....	197	7912.....	128, 237
5967x.....	178	7255x.....	198	7913.....	128, 237

7914.....	129, 234, 237, 238	10004B-B03.....	247	38353-03437.....	246
7915.....	127, 128	10004B-B04.....	247	38353-03600.....	246
7916.....	127, 128	10004B-B05.....	247	38353-04112.....	246
7917.....	128, 237	10004B-Y04.....	247	41157x.....	126, 166
7918.....	129, 238	10005B-102.....	247	50008.....	179
7919.....	129, 238	10005B-104.....	247	50008x12.....	179
7920.....	129, 238	10005B-405.....	247	50012.....	179
7921.....	129, 238	10005B-B05.....	247	50016.....	179
7922.....	129, 238	10005B-B06.....	247	50016x20.....	179
7924x.....	196	10005B-C02.....	247	50020x16.....	179
7933.....	129, 237, 238	10005B-C04.....	247	50020.....	179
7934A.....	130, 234, 238	10005B-Y05.....	247	50024.....	179
7935.....	129, 234, 238	10006B-102.....	247	50032.....	179
7936.....	129, 234, 238	10006B-104.....	247	54508.....	179
7936x.....	162, 196	10006B-106.....	247	54508x12.....	179
7937.....	129, 234, 238	10006B-306.....	247	54512.....	179
7940.....	130, 234, 238	10006B-406.....	247	54516.....	179
7941.....	130, 234, 238	10006B-606.....	247	54516x20.....	179
7942.....	129	10006B-B06.....	247	54520x16.....	179
7943.....	129	10006B-Y06.....	247	54520.....	179
7944.....	129	24704N-102.....	248	54524.....	179
7955x.....	202	24704N-104.....	248	54532.....	179
7967x.....	202	24704N-604.....	248	59008.....	179
7970.....	129	24704N-B04.....	248	59008x12.....	179
7971.....	129	24705N-104.....	248	59012.....	179
7972.....	129	24705N-605.....	248	59016.....	179
7973.....	129	24705N-B05.....	248	59016x20.....	179
7974.....	129	24706N-104.....	248	59020x16.....	179
7975.....	129	24706N-106.....	248	59020.....	179
7976.....	129	24706N-406.....	248	59024.....	179
7977.....	126	24706N-604.....	248	59032.....	179
7978.....	126	24706N-605.....	248	60008.....	180
8112x.....	196	24706N-606.....	248	60012.....	180
8165x.....	196	24706N-608.....	248	60016.....	180
8367.....	222	24706N-756.....	248	60020.....	180
8370.....	221	24706N-B06.....	248	60024.....	180
8371.....	221	24708N-106.....	248	60032.....	180
8372.....	221	24808N-108.....	248	64508.....	180
8373.....	221	24808N-406.....	248	64512.....	180
8374.....	221	24808N-608.....	248	64516.....	180
8375.....	222	24710B-Y58.....	248	64520.....	180
8376.....	222	24710B-Y60.....	248	64524.....	180
8377.....	222	24710N-108.....	248	64532.....	180
8378.....	222	24710N-608.....	248	69008.....	180
9100x.....	166, 214	24710N-610.....	248	69012.....	180
9151x.....	45, 218	33806-A.....	248	69016.....	180
9154x.....	43, 216	33806-B.....	248	69020.....	180
9205x.....	214	33806B-Y06.....	248	69024.....	180
9255x.....	215	33806B-Y24.....	248	69032.....	180
9315x.....	205, 215	33806B-Y26.....	248	106370.....	222
9355x.....	216	33806B-Y28.....	248	106470.....	222
9365x.....	208, 217	33806B-Y34.....	248	211273A.....	118
9385x.....	216	33806B-Y36.....	248	211280A.....	118
9405x.....	217	33806B-Y38.....	248		
9405x-LL.....	217	38166-01812.....	246		
9406x.....	219	38166-02137.....	246		
9435x.....	219	38166-02412.....	246		
9455x.....	218	38166-02837.....	246		
9456x.....	219	38166-03012.....	246		
9515x.....	211, 218	38166-03200.....	246		
9705x.....	219	38166-03437.....	246		
10004B-102.....	247	38166-03612.....	246		
10004B-104.....	247	38166-04112.....	246		
10004B-304.....	247	38353-01800.....	246		
10004B-305.....	247	38353-02037.....	246		
10004B-405.....	247	38353-02400.....	246		
10004B-604.....	247	38353-02837.....	246		
10004B-A04.....	247	38353-03000.....	246		
10004B-A05.....	247	38353-03200.....	246		















# Warranty

## WEATHERHEAD WARRANTY

### WARRANTY:

For one year after date of purchase, Dana Corporation warrants its products to be free from defects in materials and workmanship when properly installed and maintained. Products covered include those items contained in this catalog.

If during the warranty period, a product is discovered to be defective, Dana will, at its option, replace the warranted product or grant the purchaser a credit for the product claimed to be defective. Dana will have the sole discretion to determine whether the product was defective.

This warranty is null and void if the product has been used in the wrong application or has been damaged from an accident or willfully destroyed. In addition, this warranty will not apply to Boston Weatherhead assembly equipment, Boston Weatherhead end fittings, and Boston Weatherhead hose if the claimed defective product has been used in an assembly made from other than Boston Weatherhead parts.

NO WARRANTY OF MERCHANTABILITY OR FITNESS FOR A PARTICULAR PURPOSE, NOR ANY OTHER WARRANTY, EXPRESS OR IMPLIED, IS MADE BY DANA CORPORATION. THE FOREGOING STATES DANA CORPORATION'S ENTIRE AND EXCLUSIVE LIABILITY AND BUYER'S EXCLUSIVE REMEDY FOR ANY CLAIM OR DAMAGES IN CONNECTION WITH THE SALE OF THE PRODUCTS HEREUNDER. IN NO EVENT SHALL DANA CORPORATION BE LIABLE FOR ANY SPECIAL, INCIDENTAL, OR CONSEQUENTIAL DAMAGES WHATSOEVER.

SOME STATES DO NOT ALLOW THE EXCLUSION OR LIMITATION OF INCIDENTAL OR CONSEQUENTIAL DAMAGES, SO THE ABOVE LIMITATION MAY NOT APPLY TO YOU.

THIS WARRANTY GIVES YOU SPECIFIC LEGAL RIGHTS AND YOU MAY ALSO HAVE OTHER LEGAL RIGHTS WHICH VARY FROM STATE TO STATE.

### CLAIM INFORMATION:

To make a claim under this warranty:

1. Return the defective product along with the purchase receipt and a copy of this certificate to your local distributor or Dana sales representative or to the attention: Engineering Lab, at the following address:

Hose and Fittings  
Dana Corporation  
Weatherhead Division  
U.S. Route 24, East  
Antwerp, OH 45813

Tooling  
Dana Corporation  
Boston Weatherhead Division  
1380 South Williams Drive  
Columbia City, IN 46725

2. In the event of a question or difficulty, contact your local distributor, Dana sales representative or Boston Weatherhead Product Engineering at the above address.

**Check Out [www.bostonweatherhead.com](http://www.bostonweatherhead.com)  
For Information Regarding Fluid Connectors, Hose of Teflon®  
& Transfer Hose Products:**

- Distributor Listings
- Quality Awards
- Technical Support Netlink
- The Expert® On-Line Catalog
- Latest Literature & New Products
- For Current Hose End & Tool Selector Chart Data

**Conversion Chart**

Inches			Inches			Inches			Inches		
Fractions	Decimals	MM	Fractions	Decimals	MM	Fractions	Decimals	MM	Fractions	Decimals	MM
-	.0004	.0100	-	.2165	5.5000	29/64	.4530	11.5090	23/32	.7190	18.2560
-	.0040	.1000	7/32	.2190	5.5560	15/32	.4690	11.9060	-	.7283	18.5000
-	.0100	.2500	15/64	.2340	5.9530	-	.4724	12.0000	47/64	.7340	18.6530
1/64	.0156	.3970	-	.2362	6.0000	31/64	.4840	12.3030	-	.7480	19.0000
-	.0197	.5000	1/4	.2500	6.3500	-	.4920	12.5000	3/4	.7500	19.0500
-	.0295	.7500	-	.2559	6.5000	1/2	.5000	12.7000	49/64	.7656	19.4470
1/32	.0313	.7940	17/64	.2656	6.7470	-	.5118	13.0000	25/32	.7810	19.8440
-	.0394	1.0000	-	.2756	7.0000	33/64	.5156	13.0970	-	.7874	20.0000
3/64	.0469	1.1910	9/32	.2810	7.1440	17/32	.5310	13.4940	51/64	.7970	20.2410
-	.0590	1.5000	-	.2953	7.5000	35/64	.5470	13.8910	13/16	.8125	20.6380
1/16	.0620	1.5880	19/64	.2970	7.5410	-	.5512	14.0000	-	.8268	21.0000
5/64	.0781	1.9840	5/16	.3120	7.9380	9/16	.5630	14.2880	53/64	.8280	21.0340
-	.0787	2.0000	-	.3150	8.0000	-	.5710	14.5000	27/32	.8440	21.4310
3/32	.0940	2.3810	21/64	.3280	8.3340	37/64	.5790	14.6840	55/64	.8590	21.8280
-	.0984	2.5000	-	.3350	8.5000	-	.5906	15.0000	-	.8662	22.0000
7.64	.1090	2.7780	11/32	.3440	8.7310	19/32	.5940	15.0810	7/8	.8750	22.2250
-	.1181	3.0000	-	.3543	9.0000	39/64	.6090	15.4780	57/64	.8906	22.6220
1/8	.1250	3.1750	23/64	.3590	9.1280	5/8	.6250	15.8750	-	.9055	23.0000
-	.1378	3.5000	-	.3740	9.5000	-	.6299	16.0000	29/32	.9062	23.0190
9/64	.1410	3.5720	3/8	.3750	9.5250	41/64	.6406	16.2720	59/64	.9220	23.4160
5/32	.1560	3.9690	25/64	.3910	9.9220	-	.6496	16.5000	15/16	.9375	23.8130
-	.1575	4.0000	-	.3937	10.0000	21/32	.6560	16.6690	-	.9449	24.0000
11/64	.1720	4.3660	13/32	.4060	10.3190	-	.6693	17.0000	61/64	.9530	24.2090
-	.1770	4.5000	-	.4130	10.5000	43/64	.6720	17.0660	31/32	.9690	24.6060
3/16	.1875	4.7630	27/64	.4220	10.7160	11/16	.6875	17.4630	-	.9843	25.0000
-	.1969	5.0000	-	.4331	11.0000	45/64	.7030	17.8590	63/64	.9844	25.0030
13/64	.2030	5.1590	7/16	.4380	11.1130	-	.7087	18.0000	1	1.0000	25.4000

For full conversion chart see page 252.

Distributed by:

**Technical Support: 1-800-PRO-DANA  
(776-3262)**

Boston Weatherhead Division  
Division Office:  
P.O. Box 1708  
Brentwood, TN 37024-1708

[www.bostonweatherhead.com](http://www.bostonweatherhead.com)

**CERTIFIED  
ISO 9000**

**BUILT TO A TOUGHER STANDARD™**

**BOSTON WEATHERHEAD™**

